

WHELEN[®]

ENGINEERING COMPANY INC.

51 Winthrop Road
 Chester, Connecticut 06412-0684
 Phone: (860) 526-9504
 Fax: (860) 526-2009
 Internet: www.whelen.com
 Sales/Service e-mail: aviation@whelen.com

Installation Guide:
Model 70980()-series
Model 7098000
P/N:01-0770980-00
01-0770980-01

Infra-Red LED Flashing Light Assembly

OPERATING INSTRUCTIONS:

Operational Voltage:28 VDC (Nominal)
Average Input Current:0.1 Amps
Peak Input Current:0.63 Amps @ .25 Seconds

INSTALLATION PROCEDURES: The following information is to assist in the installation of a Whelen IR LED Light System.

1. The installation procedure described in the following text will be confined to a single light installation, but is identical for multiple light installations.
2. Using the "suggested mounting hole pattern" prepare the aircraft for means to secure the IR LED Flashing Light assembly.
3. Connect the light inputs according to the chart shown. Connect the power lead to an appropriately sized breaker. Connections to be in accordance with FAA approved methods. Insure that the wire leads and the pressure venting tube are all clear of any obstructions and secure as required. The pressure venting tube may be trimmed to minimum length of 1" from base.
4. Remove and discard the 3 screws from the lens retainer. Remove the retainer and lens. CAUTION! Do not touch the LEDs with either fingers or sharp objects. This could soil and/or damage the LED and effect the optical performance of the LEDs. Insert the appropriate hardware through the counter-bored holes and secure the assembly. Reinstall the gasket, lens and retainer. Confirm proper gasket fit. Install the nylon patch lens screws with 5-7 in./lbs. torque.
5. Check all avionics systems for interference from this installation.
6. A flight check should be performed by a properly certified pilot.
7. All inverted (bottom) mounted units shall require waterproofing of the mounting hardware. An application of single-part silicone (RTV) or equivalent applied over top of the mounting hardware, after installation, is recommended. Reference page 2 for an illustration. Inverted and/or standard mounted units, when necessary, may require waterproofing around any open area where water could get in. Specifically, the lens to the flasher base assembly, and the flasher base assembly to the aircraft.
8. Update aircraft records, complete Form 337 and obtain FAA field approval for installation, if necessary.

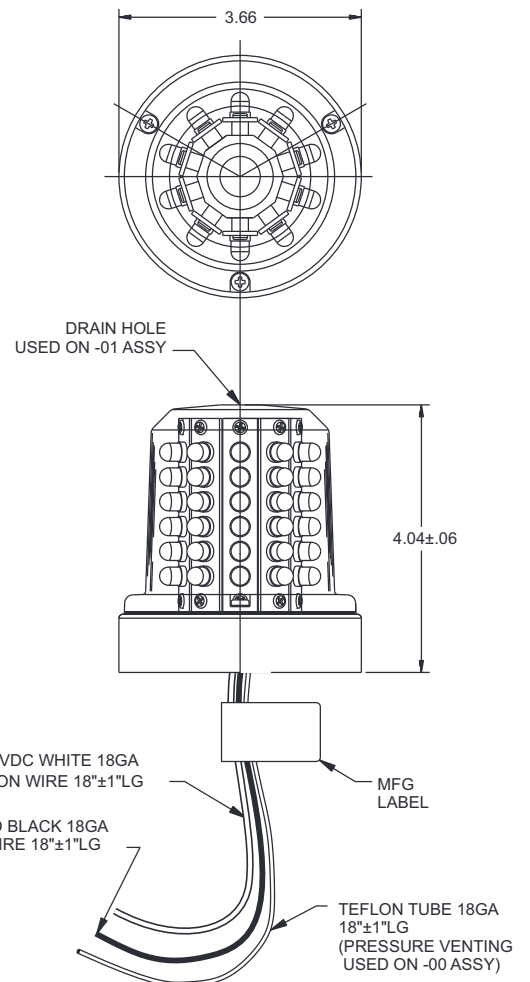

Aviation

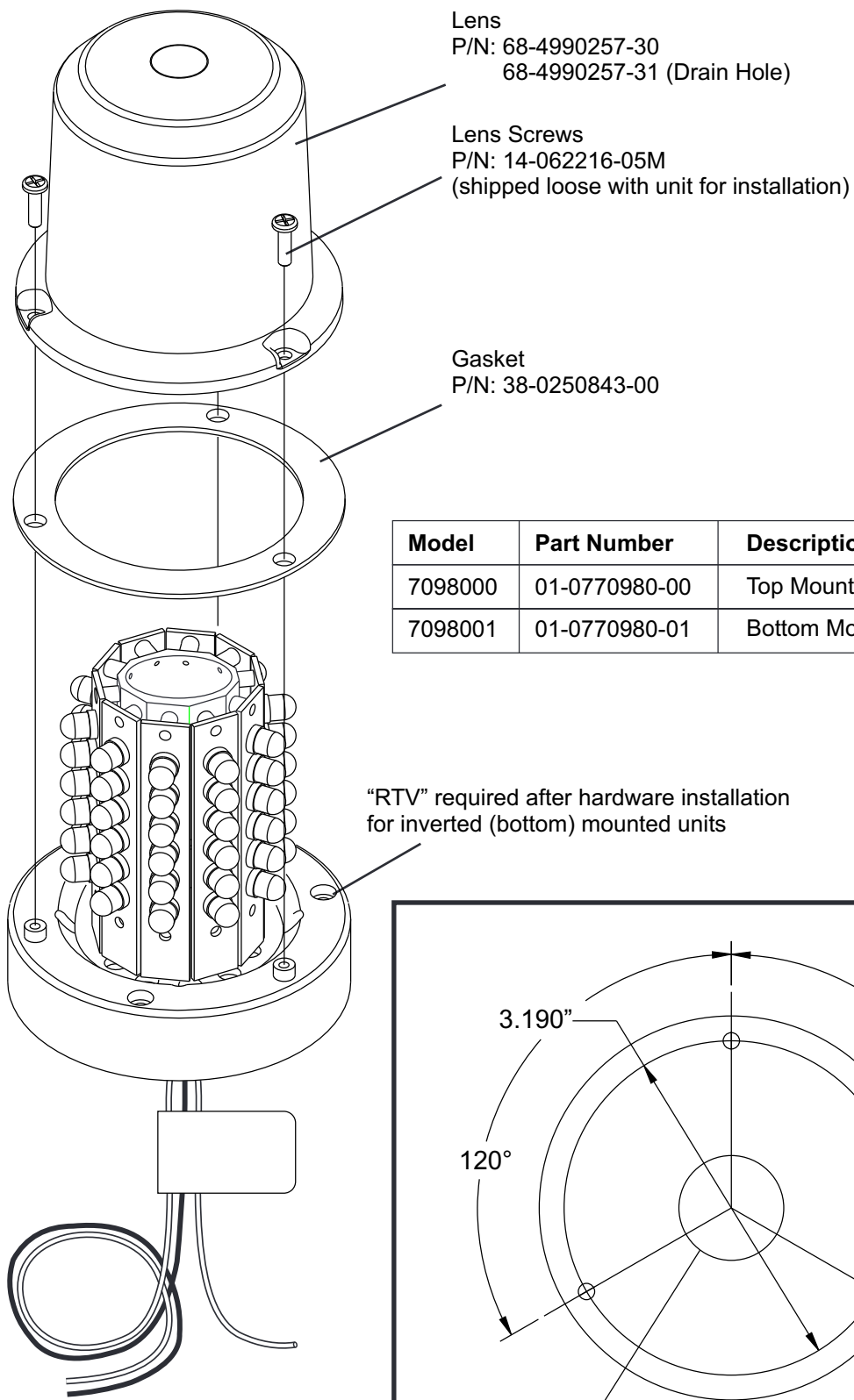

Model	Part Number	Description
7098000	01-0770980-00	Top Mount
7098001	01-0770980-01	Bottom Mount

