



WHELEN AEROSPACE TECHNOLOGIES

Phone: (860) 526-9504

Internet: www.flyWAT.com

Sales/Service e-mail: info@flyWAT.com

Installation Guide/ICA:

Model 7198700

P/N:01-0771987-00

LED Anti-Collision Light Assembly

TSO-C96a
CLASS III
APPROVED

The conditions and tests required for TSO approval of this article are minimum performance standards. Those installing this article either on or within a specific type or class of aircraft must determine that the aircraft installation conditions are within the TSO standards which include any accepted integrated non-TSO functions. TSO articles and any accepted integrated non-TSO function(s) must have separate approval for installation in an aircraft. The article may be installed only according to 14 CFR part 43 or the applicable airworthiness requirements.

⚠ WARNING: This product can expose you to chemicals including Methylene Chloride which is known to the State of California to cause cancer, and Bisphenol A, which is known to the State of California to cause birth defects or other reproductive harm. For more information go to www.P65Warnings.ca.gov.

EQUIPMENT LIMITATIONS: An approved Anti-Collision lighting system consists of two lights, one located on each wingtip. The assembly should be mounted as far outboard on the aircraft as practical. The assembly must be mounted parallel to the vertical and horizontal centerlines of the aircraft to project the patterns properly. A separate flasher assembly such as model 7198517 is required for each light assembly.

Certain types of installations may require additional testing.

AIRWORTHINESS LIMITATIONS: The Airworthiness Limitations section is FAA approved and specifies inspections and other maintenance required under §43.16 and §91.403 of the Federal Aviation Regulations, unless an alternative program has been approved.

No airworthiness limitations are associated with the installation of the LED anti-collision light.

CONTINUED AIRWORTHINESS: Model 71987 anti-collision light assembly is designed with 3 banks of 7 LEDs. If any one LED fails (per bank), the unit may be replaced at the discretion of the operator. Should more than one LED (per bank) or a bank of LEDs fail, the flasher assembly should be checked. If the flasher checks good, replace the light assembly.

Note: To reduce eye strain use an optical filter such as dark glasses or a blue covering dome during LED inspection.

Inspect the lens and replace if there is excessive scratching, pitting, discoloration or cracking. For additional lens maintenance detail, see SAE ARP5637.

PERIODIC INSPECTIONS: An annual inspection shall be performed unless the OEM specifies a shorter interval.

INSTALLATION PROCEDURES: The following information provides guidelines for the installation of the WAT LED anti-collision light. Please refer to the OEM manual for your aircraft for specific removal and installation instructions.

1. Using the mounting detail information provided, prepare the aircraft for means to secure the light assembly.
2. Connect the light inputs according to the chart shown. Connections to be in accordance with FAA approved methods.
Caution: Do not connect the LED light assembly to a Xenon discharge-style strobe power supply.
3. Carefully remove and discard the 2 screws from the retainer.
CAUTION: Do not touch the LED with either fingers or sharp objects as this could soil and/or damage the LED and affect the optical performance of the light.
4. Using the appropriate hardware install the unit to the aircraft. Insure that all leads are clear of any obstructions and secured as required.
5. Place the light switches in the ON position and verify proper operation of the Whelen lights.
6. Check all avionics systems for interference from this installation.
7. A flight check should be performed by a properly certified pilot.
8. When necessary, waterproof the light base to the aircraft. Apply single part silicone (RTV) or equivalent around any open area where water could get in. Do not cover the drain hole.
9. If required, update aircraft records utilizing FAA Field Approval (Form 337) or equivalent.

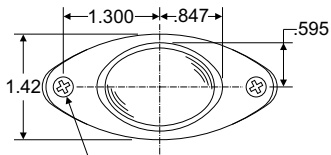

2 X #6-32 PHMS FOR SHIPPING PURPOSE ONLY

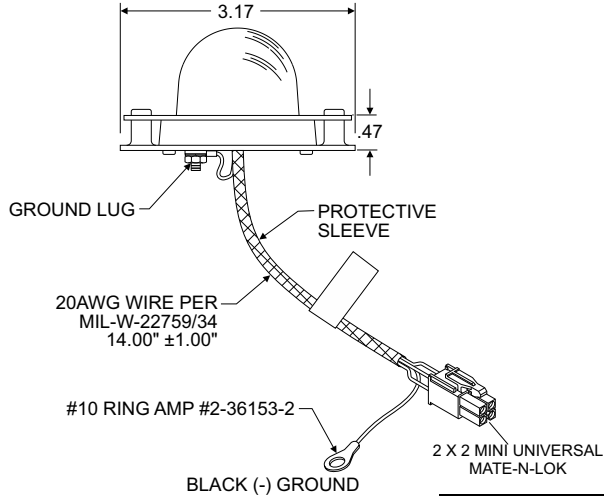

CONNECTOR WIRING	
POS 1	- CATHODE
POS 2	- CATHODE
POS 3	- CATHODE
POS 4	- ANODE

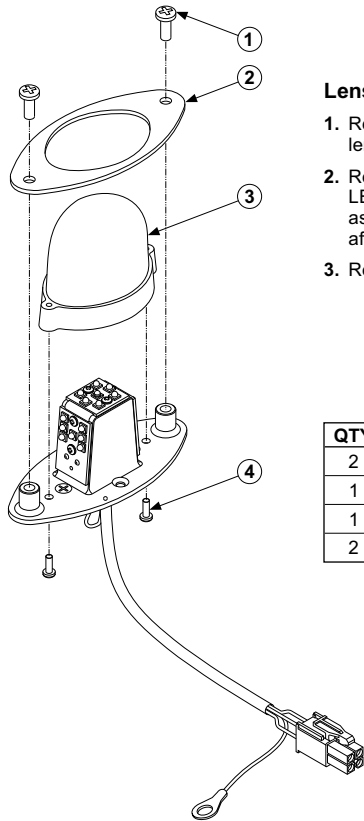

Lens Replacement

1. Remove the 2 screws (Item 4) from the lens.
2. Replace lens. CAUTION! Do not touch the LEDs with either fingers or sharp objects as this could soil or damage the LEDs and affect the optical performance of the light.
3. Re-install the 2 screws (item 4).

QTY	ITEM	PART NUMBER	DESCRIPTION
2	1	MS51957-28	SCREW, #6-32 x 3/8 PPHMS (Shipping-only)
1	2	19-171997-000	BACKER PLATE
1	3	68-4971993A30	LENS, CLEAR PLASTIC, HARDCOATED
2	4	15-026416-040	SCREW, #2 x 1/4 PPH PLASTITE