

MicroBurst™ Series Lighting

LED Wingtip and Tail Lighting for Experimental and Light Sport Aircraft

Product does not meet the requirements of 91.205(c), required equipment for night flight. Airplanes certified for night operation should not consider this product.

MicroBurst I Installation...

1. Drill two #4-40 mounting holes per suggested mounting pattern.
2. Connect the wires using the wire chart. All leads must be connected by FAA approved techniques using approved hardware.
3. Make sure the existing system is equipped with an appropriate sized breaker.
4. Remove two #4-40 screws from the MicroBurst taillight assembly.
5. Install the light assembly and insure that all leads are clear of any obstructions and ty-wrap as required.
6. Remount the lens and retainer onto the assembly. Attach the lens and retainer with two #4-40 screws. Secure light assembly using approved vibration resistant hardware methods.

SPECIFICATIONS:

Nominal Operational Voltage: 14 VDC
Typical Input Current:
 LED Strobe Light (Average): 0.15 Amps
 LED Strobe Light (Pulse): 0.80 Amps
 LED Strobe Light Flashrate: 45± 5 per min.
 Tail Navigation Light: 0.2 Amps
 Total Weight: 0.15 lbs.

Replacement Lens P/N 68-3970991-30

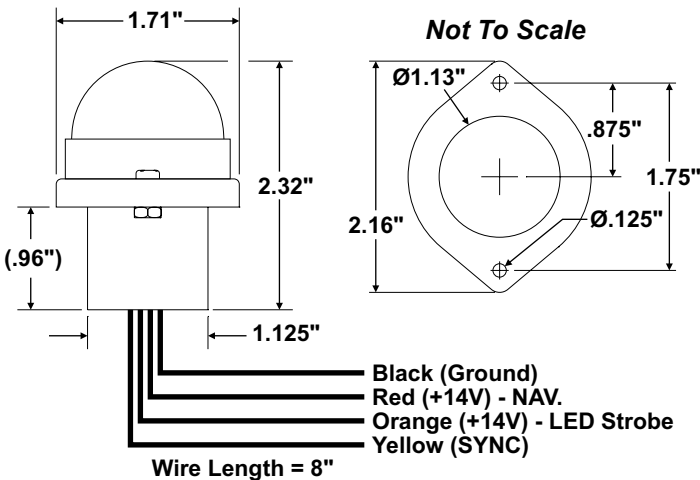

MicroBurst II & III Installation...

1. Drill three #4-40 mounting holes per suggested mounting pattern.
2. Connect the wires using the wire chart. All leads must be connected by FAA approved techniques using approved hardware.
3. Make sure the existing system is equipped with an appropriate sized breaker.
4. Remove two #4-40 screws from the MicroBurst wingtip light assembly to remove the lens retainers. Save these screws. Remove the lens and locate the three mounting holes.
5. Install the light assembly with gasket and insure that all leads are clear of any obstructions and ty-wrap as required. Secure light assembly using approved vibration resistant hardware methods.
6. Remount the lens and retainers onto the assembly. Attach the lens and retainer with the two saved screws.

SPECIFICATIONS:

	MicroBurst II	MicroBurst III
Nominal Operational Voltage:	14 VDC	14VDC
Typical Input Current:		
LED Forward Nav Light:	0.2 Amps	0.25 Amps
LED Strobe Light (Average):	0.2 Amps	0.2 Amps
LED Strobe Light (Pulse):	1.20 Amps	1.20 Amps
LED Strobe Light Flashrate:	45± 5 /min.	45± 5 /min.
Total Weight:	0.2 lbs.	0.21 lbs.

Replacement Lens P/N 68-3971132A30

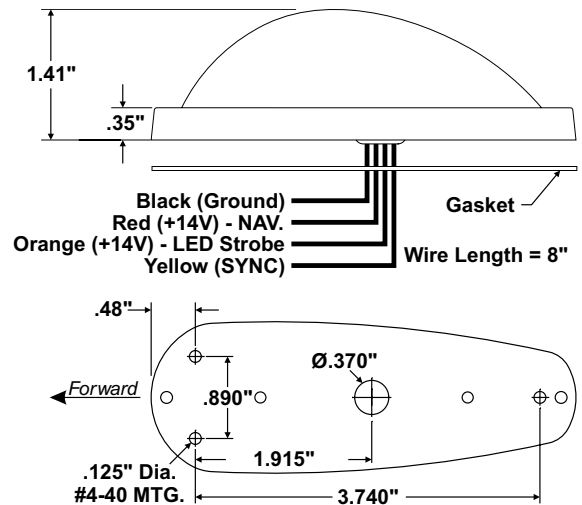

NOTE: Connecting the SYNC (Yellow) wires together will cause those lights to flash at the same time. If synchronization is not necessary or desired, the connection may be left open.



51 Winthrop Road
 Chester, Connecticut 06412-0684
 Phone: (860) 526-9504
 Fax: (860) 526-2009
 Internet: www.whelen.com
 Sales/Service e-mail: aviation@whelen.com