

WHELEN AEROSPACE TECHNOLOGIES

Phone: (860) 526-9504

Internet: www.flyWAT.com

Sales/Service e-mail: info@flyWAT.com

Installation Guide/ICA:
Aviation model(s) OR6502G, OR6502R
P/N 01-0790725-11, 01-0790725-12

Orion 650 Wingtip Position/Anti-Collision Lighthead

TSO-C30c
TYPE I, II
APPROVED

TSO-C96a
CLASS III
APPROVED

The conditions and tests required for TSO approval of this article are minimum performance standards. Those installing this article either on or within a specific type or class of aircraft must determine that the aircraft installation conditions are within the TSO standards which include any accepted integrated non-TSO functions. TSO articles and any accepted integrated non-TSO function(s) must have separate approval for installation in an aircraft. The article may be installed only according to 14 CFR part 43 or the applicable airworthiness requirements.

WARNING: This product can expose you to chemicals including Methylene Chloride which is known to the State of California to cause cancer, and Bisphenol A, which is known to the State of California to cause birth defects or other reproductive harm. For more information go to www.P65Warnings.ca.gov.

SPECIFICATIONS:

Nominal Operational Voltage: 28VDC
Input Current:
Position Lights: 0.2 Amps
Anti-Collision Light (Avg.): 0.2 Amps
Anti-Collision Light (Pulse): 1.05 Amps
Flashrate: 45 ± 5 FPM

EQUIPMENT LIMITATIONS:

An approved lighting system consists of three lights, one located on the tail and one located on each wingtip. Model OR650() is a wingtip forward position and anti-collision light. The assembly should be mounted as far outboard on the aircraft as practical. The baseplate must be mounted parallel to the vertical and horizontal centerlines of the aircraft to project the patterns properly. Model OR650() exceeds the TSO-C96a Class III anti-collision photometric requirements from 0 to 180 degrees around the horizontal plane.

Certain types of installations may require additional testing.

AIRWORTHINESS LIMITATIONS:

The Airworthiness Limitations section is FAA approved and specifies inspections and other maintenance required under §43.16 and §91.403 of the Federal Aviation Regulations, unless an alternative program has been approved.

No airworthiness limitations are associated with the installation of the LED position/anti-collision light.

CONTINUED AIRWORTHINESS:

The forward position light is designed with Green or Red LEDs. The anti-collision light is designed with 18 white LEDs. If any one LED fails, the unit must be repaired or replaced.

Inspect the lens, replace if there is excessive scratching, pitting, discoloration or cracking. For additional lens maintenance detail see SAE ARP5637.

Note: To reduce eye strain, use an optical filter such as dark glasses or a blue covering dome during LED inspection.

PERIODIC INSPECTIONS:

An annual inspection shall be performed unless the OEM specifies a shorter interval.

INSTALLATION PROCEDURES:

The following information is to assist you in installing a WAT light system.

- 1. Choose the appropriate light assembly.
2. Using the mounting detail information provided, prepare the aircraft for means to secure the light assembly.
3. Carefully remove the #4 phillips head screw and lens retainer. Remove the lens from the light assembly by lifting the rear of the lens approximately 1/2". Now slide the lens rearward approximately 1/4" and lift upwards to remove. CAUTION! To avoid potential damage, do not touch the LEDs with either fingers or sharp objects. Remove the 3 Phillips head screws securing the baseplate to the light assembly. Remove baseplate.
4. Using the appropriate hardware install the baseplate directly to the aircraft.
5. Route the wires through the opening in the baseplate. Connect the light inputs according to the chart shown. Connect the power lead to an appropriately sized breaker. Connections to be according to FAA approved methods.

Note: SYNC is a low-power, bi-directional control signal. Connecting to the synchronize signal of any WAT LED anti-collision assembly to another WAT

- anti-collision assembly will cause the lights to flash at the same time. If Synchronization is not necessary, the connection may be left open.
6. Re-install the light assembly on to the baseplate and insure that all leads are clear of any obstructions and secured as required. Note that proper orientation is achieved with the drain hole down.
7. Install lens in the reverse order as removal and return the lens retainer to its installed location. Note: Visually confirm that the lens and retainer are fully and properly seated. Re-insert #4 phillips head screw and tighten firmly.
8. When necessary, seal the light to the aircraft. Apply sealant around the perimeter of the base. Do not cover the drain hole.
9. Check all avionics systems for interference from this installation.
10. A flight check should be performed by a properly certified pilot.
11. If required, update aircraft records utilizing FAA Field Approval (Form 337) or equivalent.

Mounting Detail

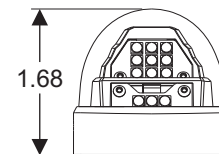
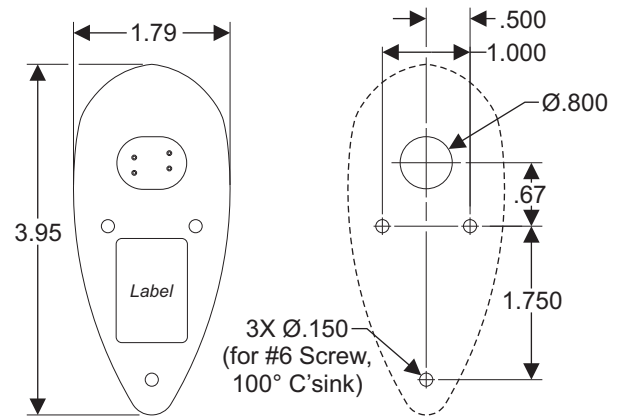

WIRING

White.....+28VDC (ACL)
Orange.....+28VDC (POS)
Yellow.....SYNC
Black.....Ground

10"±1.0"
20 AWG
MIL-22759/43 Wire

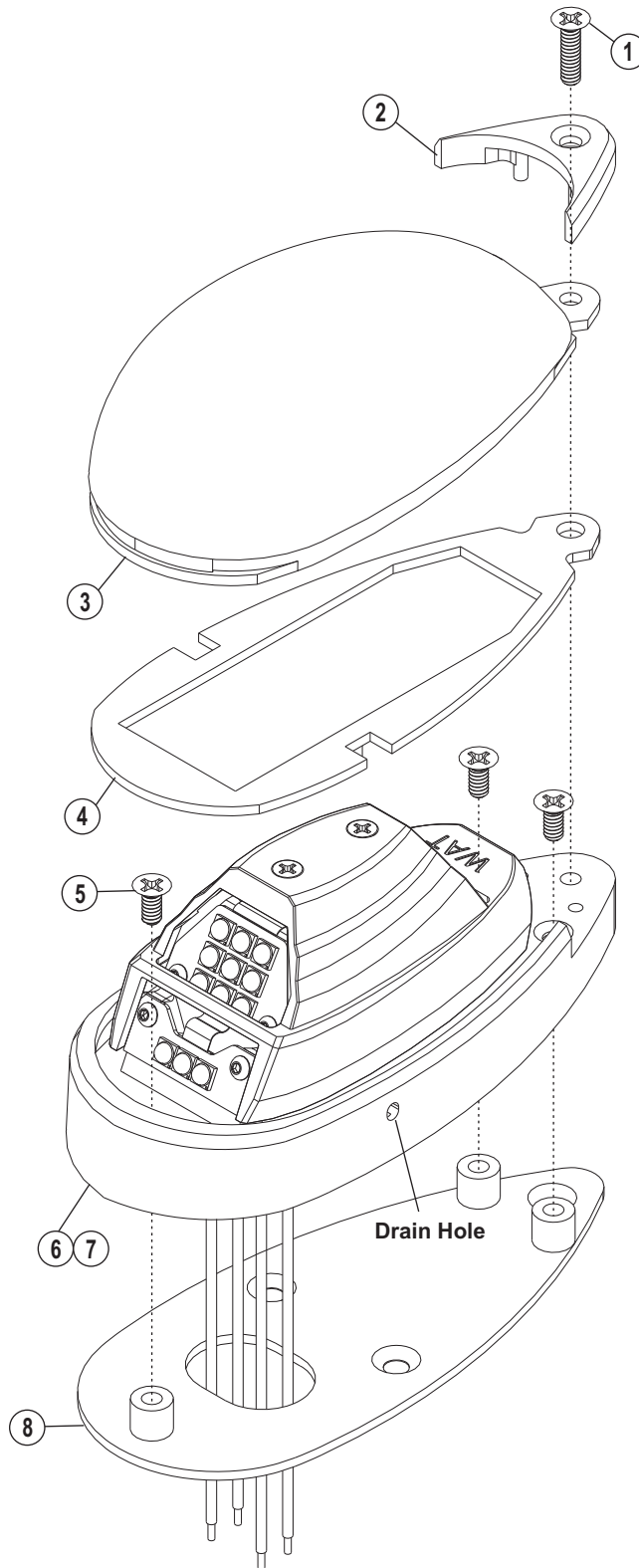

QTY	QTY	ITEM	PART NUMBER	DESCRIPTION
	*		01-0790725-11	OR6502G Wingtip Position/Anti-Collision Light, 28V (Green)
*			01-0790725-12	OR6502R Wingtip Position/Anti-Collision Light, 28V (Red)
1	1	1	14-0050581-05	Screw, 4-40 x 7/16 P100FH CSNK MS24693-C5
1	1	2	19-151088-000	Retainer, Lens
1	1	3	01-0251094-01	Lens Assy
1	1	4	38-0231382-01	Gasket, Lens
3	3	5	14-0050581-02	Screw, 4-40 x 1/4 P100FH CSNK MS24693-C2
-	1	6		OR6502G Assembly (Green)
1	-	7		OR6502R Assembly (Red)
1	1	8	07-551089-100	Adapter, Mounting