



WHELEN AEROSPACE TECHNOLOGIES

Phone: (860) 526-9504
 Fax: (860) 526-2009
 Internet: www.flyWAT.com
 Sales/Service e-mail: info@flyWAT.com

**Installation Guide/ICA:
 Model 71080()-series
 Model(s) 7108000, 7108050
 P/N(s):01-0771080-00
 01-0771080-50
 LED Flashing Anti-Collision
 Light Assembly**

TSO-C96a
 CLASS I, III;
 APPROVED

The conditions and tests required for TSO approval of this article are minimum performance standards. Those installing this article either on or within a specific type or class of aircraft must determine that the aircraft installation conditions are within the TSO standards which include any accepted integrated non-TSO functions. TSO articles and any accepted integrated non-TSO function(s) must have separate approval for installation in an aircraft. The article may be installed only according to 14 CFR part 43 or the applicable airworthiness requirements.

OPERATING INSTRUCTIONS:

Operational Voltage: 14 / 28 VDC nominal
Average Input Current: 0.90 / 0.45 Amps
Peak Input Current: 4.0 / 2.0 Amps @ .3 Seconds

The Model 71080 series LED anti-collision light assembly meets the requirements of FAR 91.205(c)(3).

EQUIPMENT LIMITATIONS: An approved anti-collision light assembly should be located so that the light will not impair the crew's vision or detract from the conspicuity of the position lights. The baseplate must be mounted parallel to the vertical and horizontal centerlines of the aircraft to project the patterns properly.

Certain types of installations may require additional testing.

AIRWORTHINESS LIMITATIONS: The Airworthiness Limitations section is FAA approved and specifies inspections and other maintenance required under §43.16 and §91.403 of the Federal Aviation Regulations, unless an alternative program has been approved.

No airworthiness limitations are associated with the installation of the LED anti-collision light.

CONTINUED AIRWORTHINESS: The 71080 series LED anti-collision light assembly is designed with 8 vertical columns consisting of 4 LEDs each. Should any one LED or any vertical column fail, the unit must be repaired or replaced. Inspect the lens and replace if there is excessive scratching, discoloration or cracking.

Inspect the lens, replace if there is excessive scratching, pitting, discoloration or cracking. For additional lens maintenance detail see SAE ARP5637.

NOTE: To reduce eye strain, use an optical filter such as dark glasses or a blue covering dome during LED inspection.

PERIODIC INSPECTIONS: An annual inspection shall be performed unless the OEM specifies a shorter interval.

INSTALLATION PROCEDURES: The following information is to assist in the installation of a WAT LED Anti-collision Light System.

1. Using the mounting detail information provided, prepare the aircraft for means to secure the light assembly.
2. Carefully remove the #4 Phillips screw and lens retainer. Remove the lens. **CAUTION!** Do not touch the LEDs with either fingers or sharp objects. This could soil and/or damage the LED and effect the optical performance of the LEDs.
3. Connect the light inputs according to the chart shown. Connect the power lead to an appropriately sized breaker. Connections to be in accordance with FAA approved methods.
4. Install the light assembly and insure that all leads are clear of any obstructions and secured as required.
5. Install gasket, lens and lens retainer. Confirm proper gasket fit. Reinsert screws and tighten firmly.
6. All inverted (bottom) mounted units shall require waterproofing of the base assembly to the aircraft. NOTE: Drill a 1/8" hole in the center of the lens for bottom mount units.
7. Check all avionics systems for interference from this installation.
8. A flight check should be performed by a properly certified pilot.
9. If required, update aircraft records utilizing FAA Field Approval (Form 337) or equivalent.

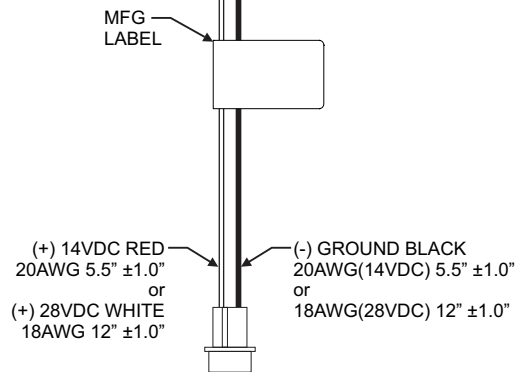
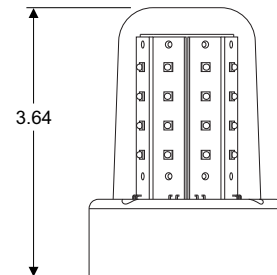
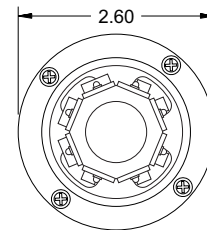

-00 (28VDC) Connector Wiring		
POS 1	(+) 28VDC	White
POS 2	(-) GROUND	Black

-50 (14VDC) Connector Wiring		
POS 1	(+) 14VDC	Red
POS 2	(-) GROUND	Black

Aviation

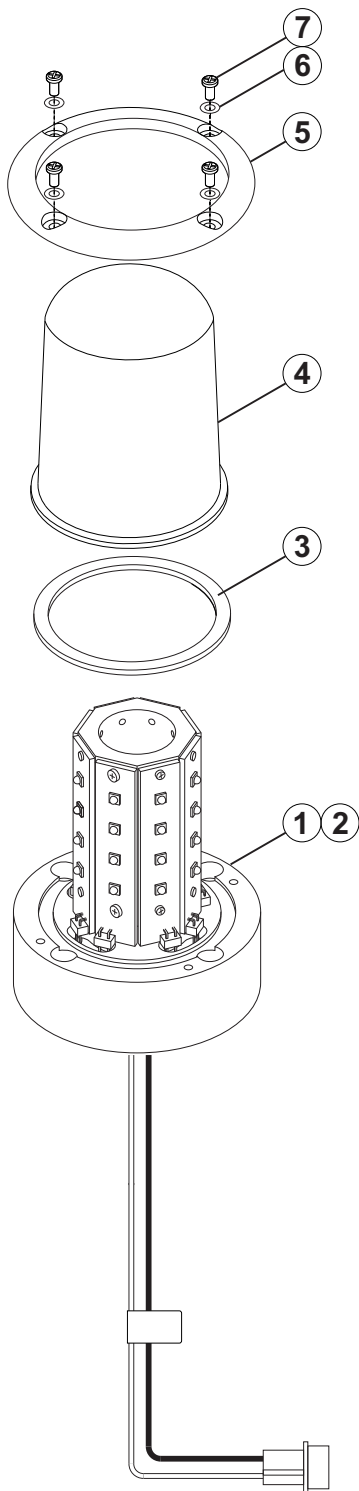

QTY	QTY	ITEM	PART NUMBER	DESCRIPTION
	*		01-0771080-00	MODEL 7108000 (28V)
	*		01-0771080-50	MODEL 7108050 (14V)
-	1	1	_____	ASSY, 28V LED ANTI COLLISION LIGHT 71080
1	-	2	_____	ASSY, 14V LED ANTI COLLISION LIGHT 71080
1	1	3	38-0250885-00	GASKET, LENS MODEL 71055 SERIES
1	1	4	68-4971082A30	LENS, CLEAR LED ANTI-COLLISION HARDCOAT
-	1	5	19-171047-100	RETAINER, LENS IRIDITE COMPLETE
4	4	6	16-0050506135	WASHER, #4 LOCK-SPRING MS35338-135
4	4	7	140050505-14	SCREW, 4-40 X 5/16 PPHMS MS51957-14

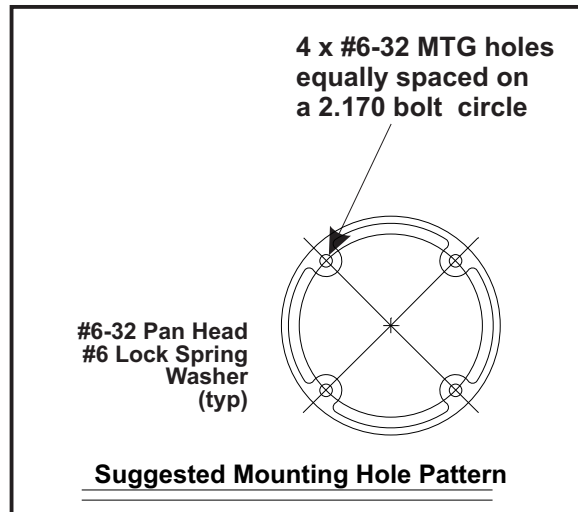

Pos. 1	(+) 14/28 Volts	Red/White
Pos. 2	(-) Ground	Black