



**WHELEN**® AEROSPACE TECHNOLOGIES

**ANTI-COLLISION LIGHT SYSTEMS  
INSTALLATION AND SERVICE MANUAL  
MARCH 2019**



**Approved under  
STC SA6NE  
STC SA21NE  
STC SA615EA  
STC SA800EA**

*ISO 9001 Registered QMS*

# INDEX

PAGE NUMBER		
2	Table Of Contents/Company Information	42-43 Strobe Lighthouse Assemblies - A470A Series, Models A450, H102, H103
3	Strobe System Requirements	44-45 Strobe Lighthouse Assemblies - A650PG/PR Series
4	Aircraft not specifically mentioned on the eligibility list	46-47 LED Light Assemblies - 71110( ) Series
5	Strobe System Wiring	48 Strobe Lighthouse Assemblies - A610 Series / A612 Series
6	Strobe Power Supply Installation	49 Strobe Lighthouse Assemblies - A625 Series
7-8	Orion 500 LED Light Assemblies	50-51 Strobe Lighthouse Assemblies - A500A Series
9-10	Orion 650 LED Light Assemblies	52-53 LED Light Assemblies - 71011( ) Series
11-12	Orion 650E LED Light Assemblies	54-55 LED Light Assemblies - 71554( ) Series
13-15	Strobe Power Supplies - HDACF, A490ATSC, A490TCF, A490TCCF	56-57 A600 PG/PR Series
16-22	LED Light Assemblies - OR360 Series	58 A650 Series
23	LED Light Assemblies - CHROMA Series	59 Strobe Power Supply Replacement Cross Reference Listing
24-29	LED Light Assemblies - 90520( ) Series	60 Continued Airworthiness Flow Chart
30-35	LED Light Assemblies - 71080( ) Series	61-62 Strobe System Trouble-Shooting
36-37	Self Contained Light Assemblies - 70900( ) Series	63-64 Parts Breakdown - Aircraft Strobe Beacons
38-39	Self Contained Light Assemblies - 71055( ) Series	65-66 Notes
40-41	Self-Contained Light Assemblies - HRCFA Series, Models SACF, A440	67 Whelen LED & Strobe Ad



**WHELEN** AEROSPACE TECHNOLOGIES

51 WINTHROP ROAD, CHESTER, CT 06412-0684  
PHONE: (860) 526-9504 • FAX: (860) 526-2009

*Makers of Aviation, Automotive and Industrial  
Safety Lighting since 1953*

*The Finest Designed...Assembled...Tested...  
Aviation Warning Products...Manufactured In the U.S.A.*

*To view our products and contact us,  
visit Whelen at [www.flywat.com](http://www.flywat.com) or  
we can be emailed at [info@flywat.com](mailto:info@flywat.com)*

**INTRODUCTION TO WHELEN AEROSPACE TECHNOLOGIES  
ANTI-COLLISION STROBE LIGHTING SYSTEMS, STC SA800EA/  
STC SA615EA/STC SA6NE/ STC SA21NE**

Whelen Aerospace Technologies Anti-Collision Strobe Light Systems are approved under STC SA615EA, STC SA800EA, STC SA6NE, and STC SA21NE, manufactured under PMA as an approved anti-collision light for all aircraft, when installation is accomplished in accordance with the following instructions. Whelen Aerospace's Anti-Collision Strobe Light Systems are designed and approved specifically for General Aviation Aircraft, to comply to FAR 91.205(c) (3) (visual flight rule night) requirements.

Whelen Aerospace's approved Anti-Collision Strobe Light Systems can be installed on all aircraft by completing the installation with reference to this Installation and Service Manual, and the appropriate technical data listed below:

ADVISORY CIRCULAR 43.13-1A, Chapter 11, Sections 1, 2, 3 and 7, Electrical Systems.

ADVISORY CIRCULAR 43.13-2A, Chapters 1 and 2, Radio Installations.

ADVISORY CIRCULAR 43.13-2A, Chapter 4, Anti-Collision Light Installations.

ADVISORY CIRCULAR 20.21, 12-3-64, Application of Glass Fiber Laminates in Aircraft.

**ANTI-COLLISION AND POSITION LIGHT REQUIREMENTS,  
LOCATIONS, & DISTRIBUTION PATTERNS**

All aircraft must have an approved anti-collision light and position light system for nighttime operations. The position lights consist of an Aviation Red on the left side, an Aviation Green on the right, and an Aviation White taillight (REF. FAR 23.1389).

The anti-collision lighting system is required under FAR PART 91.205(c)(3). There are different requirements affecting different aircraft. These aircraft are categorized by the date of application for type certificate. Home built aircraft are determined by the date of issuance of the Experimental Operating Limitations. The different categories are as follows:

**Aircraft for which type certificate was applied for after April 1, 1957 to August 10, 1971:**

These anti-collision systems must produce a minimum of 100 effective candela in Aviation Red or White (REF. FAR 23.1397), 360° around the aircraft's vertical axis, 30° above and below the horizontal plane (REF. FAR 23.1401).

**Aircraft for which type certificate was applied for after August 11, 1971 to July 18, 1977:**

These anti-collision systems must produce a minimum of 400 effective candela in Aviation Red or White (REF. FAR 23.1397), 360° around the aircraft's vertical axis, 30° above and below the horizontal plane (REF. FAR 23.1401).

**Aircraft for which type certificate was applied for after July 18, 1977:**

These anti-collision systems must produce a minimum of 400 effective candela in Aviation Red or White (REF. FAR 23.1397), 360° around the aircraft's vertical axis, 75° above and below the horizontal plane (REF. FAR 23.1401).

\*The position lights must be wired independently of anti-collision lights.

**GENERAL AVIATION MINIMUM POSITION LIGHTING REQUIREMENTS**

For compliance to FAR Part 23.1385 through 23.1397, VFR flight rule night requirements on a General Aviation aircraft, you must have a TSO'd Aviation Red forward position light on the left and an Aviation Green forward position light on the right. See Figure 7, page 4.

These are normally mounted on the most outward extremity of the airframe so they can project their light directly in front of the aircraft 0 degree to 110 degrees left and right horizontally, and 180 degrees up and down vertically, unobstructed by any part of the aircraft.

The tail position light must project its Aviation White light toward the rear of the aircraft, 70 degrees horizontally left and right from 0 degree straight back behind the aircraft, 180 degrees up and down, 0.04 Steradian (131.36 sq. degrees) interference is allowable, reference FAR Part 23.1387(c). More than one light is acceptable.

**POSITION LIGHTS AND ANTI-COLLISION LIGHT  
DISTRIBUTION PATTERNS REQUIREMENTS**

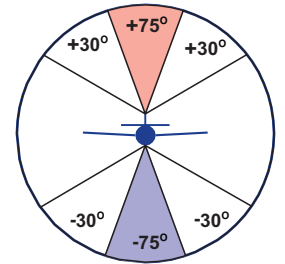
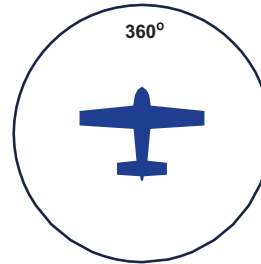

An approved anti-collision strobe light system must project light 360° around the aircraft's vertical axis. One or more strobe lights can be used.

An approved anti-collision strobe light system must project light + or - 30° above and below the horizontal plane of the aircraft. One or more strobe lights can be used. The + or - 75° projected light is required since July 18, 1977.

Approved light pattern in the horizontal plane. The anti-collision wingtip mounted lights must converge within 1200 feet directly in front and rear of the aircraft on center line. If the wingtip strobe light convergence is greater than 1200 ft. in back of the aircraft, a 3rd light is necessary.

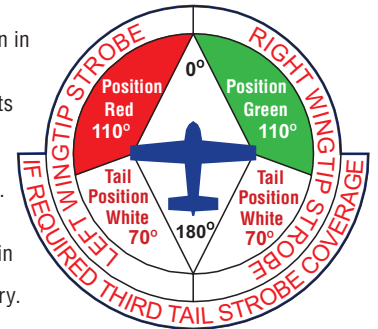

**LOCATIONS ON THE AIRCRAFT FOR  
ANTI-COLLISION STROBE LIGHTS, TO COMPLY  
TO THE LIGHT PATTERN REQUIREMENTS.**



**VERTICAL FIN**

One anti-collision strobe light mounted on the vertical fin will meet the minimum requirements on most aircraft. A half red and half white lens is recommended.



**WINGTIP**

Two wingtip strobe lights that protrude beyond the wingtip, their light converging in front and back of the aircraft within 1200 ft. is an approved anti-collision strobe light system.



**ENCLOSED WINGTIP**

Enclosed wingtip anti-collision strobe lights, require a third strobe light on the tail or vertical fin, to fill in the required light envelope. This is an approved anti-collision system.



**FUSELAGE**

In a fuselage mounted anti-collision strobe light system, a minimum of two strobe lights are necessary to get the required vertical coverage. This is an approved anti-collision system.



# AIRCRAFT NOT SPECIFICALLY MENTIONED ON THE ELIGIBILITY LIST

## ANTI-COLLISION LIGHT INSTALLATION PROCEDURES STC SA800EA / STC SA615EA / STC SA21NE

The following information is to assist in the installation of a custom Whelen anti-collision strobe light system on any aircraft, and how to return the aircraft back to service with compliance to FAR Part 91.205(c) (3).

1. Choose the anti-collision light system which is most applicable to the aircraft.
2. With reference to the STC's "Limitation and Conditions" for field of coverage requirements. Check the field of coverage of the proposed location.
3. These STC's document that Whelen's anti-collision strobe lights meet the requirements as specified in AC 43.13-2A, Chapter 4, PAR.51 (a and b) (1). STC SA615EA covers replacement of original equipment, STC SA800EA and STC SA21NE cover installation of new anti-collision light systems.
4. Vertical fin mounted anti-collision strobe beacons will conform to the FAR 23.1401, 0.5 steradian (1642 sq. degrees) maximum solid angle blockage requirements on most standard configurations (CAM 3 and FAR Part 23) high or low wing type aircraft. An average solid angle blockage for an installation of this type is 1324 sq. degrees.
5. Fuselage mounted anti-collision light systems require two (2) anti-collision strobe beacons to get the  $\pm 75$  degrees required. Two lights mounted in this manner exceed the steradian requirements of 21,600 sq. degrees total coverage.
6. Fuselage mounted anti-collision lights should be located on the fuselage center line to reduce reflection on the wings as much as possible. They should be mounted near the trailing edge of the wing, to reduce cockpit reflection.

## APPROVED METHOD OF DETERMINING ADEQUATE COVERAGE OF WING AND TAIL STROBE LIGHT INSTALLATIONS

The most practical system is the approved wingtip anti-collision strobe light system. These systems consist of two or more lights to complete the anti-collision light requirement. There is no question as to their complying to the field of coverage when the installation is completed (Reference to the following instructions).

The acceptable distance for the two wingtip anti-collision strobe lights to converge in front and back of the aircraft on center line is 1200 feet. If both wingtip anti-collision strobe lights can be seen at 1200 feet or less directly in front and back of the aircraft, it is considered a point of light source, therefore a third light is not necessary.

The wingtip anti-collision light must be located in such a way that it will project light  $\pm 75$  degrees above and below the horizontal axis of the aircraft, and the summation of the 2 or 3 lights will project light 360 degrees around the vertical axis.

**PILOT AND CREW INTERFERENCE:** In some installations it will be necessary to mask the strobe lighthouse assembly to reduce pilot annoyance. This interference problem varies from one aircraft to another of the same model, due to paint schemes and colors. The Navigation Light Detector will be a source of reflection and should be reduced in size, or masked as necessary. A small aluminum or plastic plate mounted between the navigation light and the wingtip protruding up or down as required (like some plastic navigation light detectors, and trimmed to shadow the objectionable reflected area) is simple and very effective.

The solid angle blockage must be reviewed after installing any masking that will disturb the 360 degrees by  $\pm 75$  degrees pattern. The aforementioned type masking used on wingtip lighting seldom interferes with this pattern.

## ESTABLISHING SOLID ANGLE BLOCKAGE WITH REFERENCE TO AC 43.13-2A, CHAPTER 4.

1. To determine the vertical angles to use with reference to Figure 7 and 8 of the aforementioned chapter 4, attach a long string to the subject light source location.
2. Fix a navigational-type plotter or protractor to the string with weighted thread fixed to the center of the scale for a plumb bob.
3. Level the aircraft or determine the offset angle.
4. Pull the string over the point of solid angle blockage (Ref. Fig. 6 page 4). Any angles greater than  $\pm 75$  degrees vertical are not a factor.
5. Apply the vertical and horizontal angles to the graph paper (Ref. Fig. 4.8 and instructions in text of paragraph b6 & c of Chapter 4).

A flight test will be performed by properly certified pilot with reference to paragraph 52(a) (b) of Chapter 4.

## COMPLETING THE ANTI-COLLISION LIGHT INSTALLATION

1. Check all avionics systems for interference from this installation, reference AC 43.13-2A, Chapter 4, Paragraph 52(b).
2. A flight check will be performed by a properly certificated pilot with reference to AC 43.13-2A, Paragraph 52(a) and (b).
3. If a solid angle blockage document must be established, it should be performed after all masking has been installed and all flight testing is completed. See page 3 of this manual.
4. **WATERPROOFING OF STROBE LIGHT INSTALLATIONS:** When necessary to waterproof the installation of a strobe light mounting to the aircraft, apply GE (silicone rubber) RTV 102 (or equivalent) around the open area where water could get in.
5. Label all switches and breakers, install Pilot Warning Placard.
6. Up-date aircraft records and complete form 337.

# STROBE SYSTEM WIRING

## Interconnecting Cable

1. The Whelen interconnecting cable shall be secured in place with approved aviation techniques.
2. The cable shall not parallel ADF, Gyro or Flux Gate compass leads closer than 12 inches.
3. Reference should be made to AC 43.13-1B, Chapter 11, Sections 3 and 7, when routing and fishing the interconnecting cable.
4. Leave a service loop at the strobe lighthouse end, to allow access to the connector for flash tube replacement without having to disassemble the aircraft.
5. CABLE COLORING CODE:  
**PIN 1 RED** - (Anode)  
**PIN 2 BLACK** - (Cathode, flash tube ground)  
**PIN 3 WHITE** - (Trigger)  
**SHIELD** - Ground at the power supply end only

**Caution:** When pins 1 and 2, or pins 2 and 3 are reversed, the system will appear to operate normally, however this condition will cause premature flash tube failure.

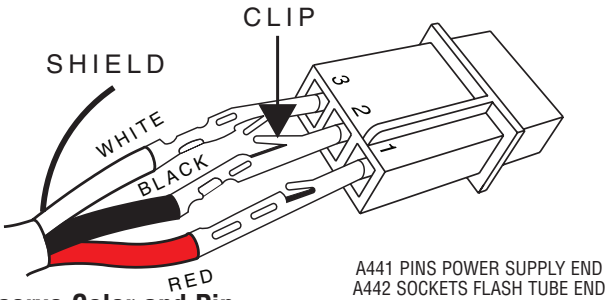

## Observe Color and Pin Numbers

The retaining clip on the side of each pin or socket of the A441 and A442 connector assemblies must be bent out (Reference illustration, Figure 5a shown above) so that they positively snap into the AMP 3 position socket nylon connector housing. If it is not possible to get a good grip, it is recommended that the pins and sockets be soldered to prevent burning of the wires.

## Intermixing Strobe Light System Equipment

### Observe Color and Pin Numbers

**Cables Connecting Strobe Lights *MUST BE* Connected Correctly!**

Whelen Engineering and Aero-flash wiring between light assemblies and remote power supplies are identical as pictured below in Figure 5b.

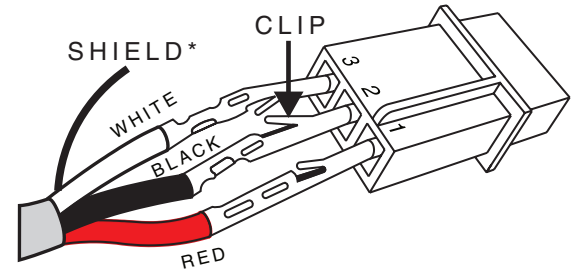

Grimes and SDI (Hoskins) wiring between light assemblies and remote power supplies are identical as pictured below in Figure 5c.

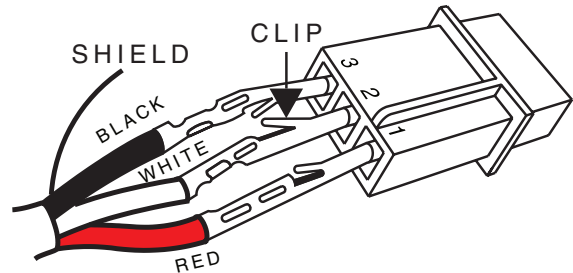

Both Grimes and SDI sometimes use MS (Cannon Type) connectors:

**Position A = RED (Anode), Position B = WHITE or BLUE (Trigger), Position C = (Cathode) BLACK or YELLOW**

## INSTALLATION CABLE KITS

All Kits include required connectors for hooking up the strobe light to the power supply only and warning placards. Cable is 16 gauge 3/c shielded. The cable diameter is .275". The weight is .050 lbs. per linear foot. **Kits do not include switches or breakers.** In order to maintain the integrity of the installation, one of the following installation kits must be used. If the installer chooses to use different cable, it must have the same or better electrical characteristics.

Model Number	Part Number	Description
HS5	.01-0750215-00	. . . . .5' Cable Kit
HT10	.01-0750218-00	. . . . .10' Cable Kit
HS30	.01-0750214-00	. . . . .30' Cable Kit
HD60	.01-0750206-00	. . . . .60' Cable Kit
HDT390	.01-0750205-00	. . . . .90' Cable Kit
HT	.01-0750216-00	. . . . .Install Kit Only No Cable

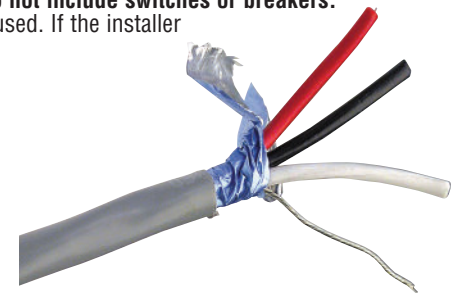

## REPLACEMENT CONNECTORS

Model Number	Part Number	Description
A441	.01-0430011-00	. . . . .3 Position Male Connector with Pins
A442	.01-0410823-00	. . . . .3 Position Female Connector with Sockets
A444	.02-0230007-00	. . . . .2 Position Male Connector with Pins
A446	.02-0230085-00	. . . . .2 Position Female Connector with Sockets



# STROBE POWER SUPPLY INSTALLATION

## INSTALLATION PROCEDURES:

### Location

1. Consider areas or locations designated by the aircraft manufacturer. Do not mount the strobe power supply closer than three (3) feet of the ADF loop.
2. For alternate locations, consider areas such as the cabin baggage compartment, the floor under the seat, nonstructural bulkheads, firewalls, etc.
3. If necessary, fabricate support brackets or shelves, and attach them to the aircraft structure to provide a mounting surface that will withstand the inertia forces stipulated in chapters 1 & 3 of AC 43.13-2A.
4. An "IA" or other representative of the FAA must approve documentation of structural integrity of the fabricated installation.
5. When installing the strobe light power supply in an inverted position, drill a 3/16" diameter hole in the lowest corner of the cover to provide for moisture drainage. Care must be taken not to let the drill protrude into the power supply, for it will inflict damage to the electronic components.
6. Specifically call out the location of the strobe light power supply on FAA form 337.

### Important Note

Your new strobe power supply has an additional circuit built-in to prevent self-ionization (steady glowing) of the strobe tubes. In some cases, when replacing older power supplies, the bare shield wire in the existing harness is pinned together at each end with the black wire. The following modification must be made to ensure proper operation.

1. At the strobe tube end of the cable, cut the shield wire and tape it off (**DO NOT CUT THE BLACK WIRE**).
2. At the power supply end of the cable, cut the shield wire and connect it to a good ground (**DO NOT CUT THE BLACK WIRE**).
3. This must be done for each strobe light connection (See Figure 6a).

## Wiring

**WARNING!!! STROBE LIGHT POWER SUPPLIES ARE POLARITY SENSITIVE. REVERSING THE INPUT POLARITY WILL CAUSE SEVERE DAMAGE TO THE POWER SUPPLY!**

Steps below: Ref. AC 43.13-1B, Chapter 11, Sections 1, 2, 3 & 7.

1. Choosing wire size of A+ input lead, refer to Paragraph 444 "Electric Wire Chart" Figure 11.7 & 11.7a, with reference to "Strobe Light Model Current" requirement chart on page 6 & 11, and "Wire and Circuit Protection Chart" Figure 11.1.
2. Shielded wire is not generally necessary, but has proven effective in reducing the possibility of radio interference.
3. The power supply shall acquire its power from a low impedance source such as the alternator or generator end of the electrical buss as close to the battery as possible. Do not ground power supply to airframe. This can attenuate emi/rfi noise to airframe causing it to act as an antennae for interference in aircraft audio & electrical systems.
4. For penetrating pressure hull, refer to the aircraft service manual.
5. Check all avionics systems for interference.

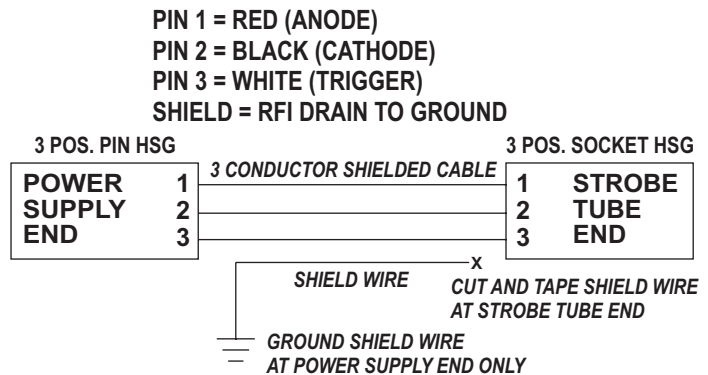

# ORION 500 LED LIGHT ASSEMBLIES

## MODEL OR5001V & OR5002V LED Tail Position/Anti-Collision Lighthouse Assembly

All LED self-contained tail mounted Position/Anti-Collision system. Eliminates the need for external power supplies and reduces current draw and provides thousands of hours of operation.



### Model OR500 Specifications

Model Numbers	Part Number	Voltage	LED Color	Anti-Collision LED Color	Operational Voltage	Input Current	Flash Rate	Weight	Approvals	Lenses
OR5001V	01-0771774V01	12 VDC	Aviation White	Aviation White	9-14 VDC	0.20 Amp (Position) 0.72 Amp Avg (ACL)	45 ± 5 FPM	0.28 lbs (132gm)	FAA TSO/ETSO-C96a Class II & III TSO/ETSO-C30c Type III	Clear Hard-coated Polycarbonate (Field Replaceable)
OR5002V	01-0771774V02	28 VDC			22-32 VDC	0.10 Amp (Position) 0.36 Amp Avg (ACL)		0.29 lbs (132gm)		

### Operation

#### EQUIPMENT LIMITATIONS:

An approved position lighting system consists of three lights, one located the tail and one on each wingtip. Model OR500 ( ) is a tail position and anti-collision light. The assembly should be mounted as far aft on the aircraft as practicable on a thermally conductive surface. The baseplate must be mounted parallel to the vertical and horizontal centerlines of the aircraft to project the patterns properly. Certain types of installations may require additional testing.

#### CONTINUED AIRWORTHINESS:

The tail position light is designed with 4 LEDs. The anti-collision light is designed with 18 LEDs. If any one LED fails, the unit must be repaired or replaced.

Inspect the lens, replace if there is excessive scratching, pitting, discoloration or cracking.

**Note:** To reduce eye strain, use an optical filter such as dark glasses or a blue covering dome during LED inspection.

#### INSTALLATION PROCEDURES:

The following information is to assist you in installing a Whelen light system.

1. Choose the appropriate light assembly.
2. Using the mounting detail information provided, prepare the aircraft for means to secure the light assembly.
3. Connect the light inputs according to the chart shown. Connect the power lead to an appropriate sized breaker. Connections to be in accordance with FAA approved methods. **Note:** SYNC is a low-power, bi-directional control signal. Connecting to the synchronize signal of any Whelen LED anti-collision assembly to another Whelen anti-collision assembly will cause the lights to flash at the same time. If synchronization is not necessary, the connection may be left open.
4. Proper installed orientation is achieved with the drain hole down. **Note:** The arrow on the label must point up. Install the light assembly on to the aircraft. Insure that all leads are clear of any obstructions and secured as required.
5. When necessary, waterproof the light base to aircraft. Apply single-part Silicone (RTV) or equivalent around any open area where water could get in. Do not cover the drain hole or the back of the unit.
6. Check all avionics systems for interference from this installation.

### Operation (cont'd)

7. A flight check should be performed by a properly certified pilot.
8. Update aircraft records, complete Form 337 and obtain FAA field approval for installation, if required

### Dimensions and Mounting Detail

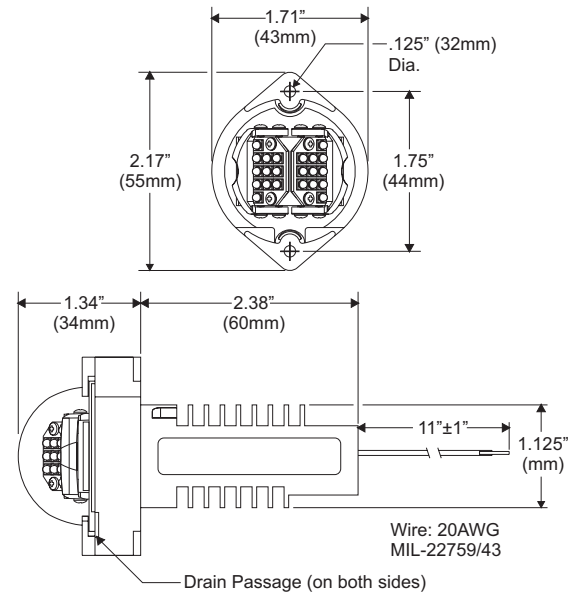

#### Suggested Mounting Detail

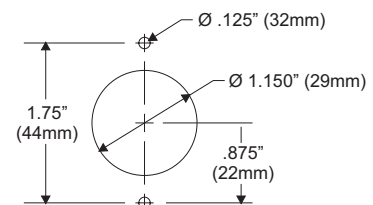

#### WIRING 12V

Red.....+12VDC (ACL)  
Orange.....+12VDC (POS)  
Yellow.....SYNC  
Black.....Ground

#### WIRING 28V

White.....+28VDC (ACL)  
Orange.....+28VDC (POS)  
Yellow.....SYNC  
Black.....Ground

## ORION Model OR5001V 12V Series Exploded View Parts

### CAUTION!

DO NOT TOUCH THE LED LENS SURFACE WITH EITHER FINGERS OR SHARP OBJECTS. THIS COULD SOIL AND/OR DAMAGE THE LENS AND EFFECT THE OPTICAL PERFORMANCE OF THE LEDs

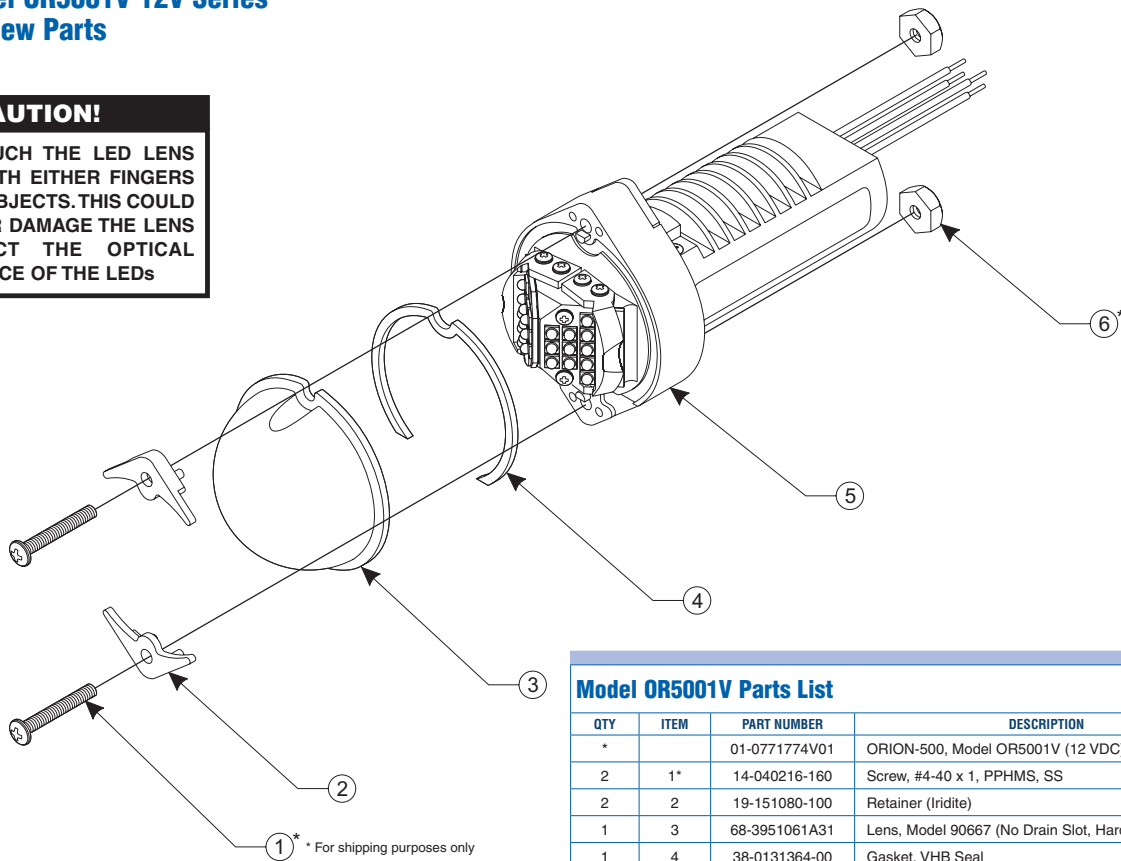

### Model OR5001V Parts List

QTY	ITEM	PART NUMBER	DESCRIPTION
*		01-0771774V01	ORION-500, Model OR5001V (12 VDC)
2	1*	14-040216-160	Screw, #4-40 x 1, PPHMS, SS
2	2	19-151080-100	Retainer (Iridite)
1	3	68-3951061A31	Lens, Model 90667 (No Drain Slot, Hardcoat)
1	4	38-0131364-00	Gasket, VHB Seal
1	5	01-0290717-00	Sub-Assy, ORION-500, Model OR5001V (12 VDC)
2	6*	13-040130-040	Nut, #4-40 X 1/4, Hex Brass

## ORION Model OR5002V 28V Series Exploded View Parts

### CAUTION!

DO NOT TOUCH THE LED LENS SURFACE WITH EITHER FINGERS OR SHARP OBJECTS. THIS COULD SOIL AND/OR DAMAGE THE LENS AND EFFECT THE OPTICAL PERFORMANCE OF THE LEDs

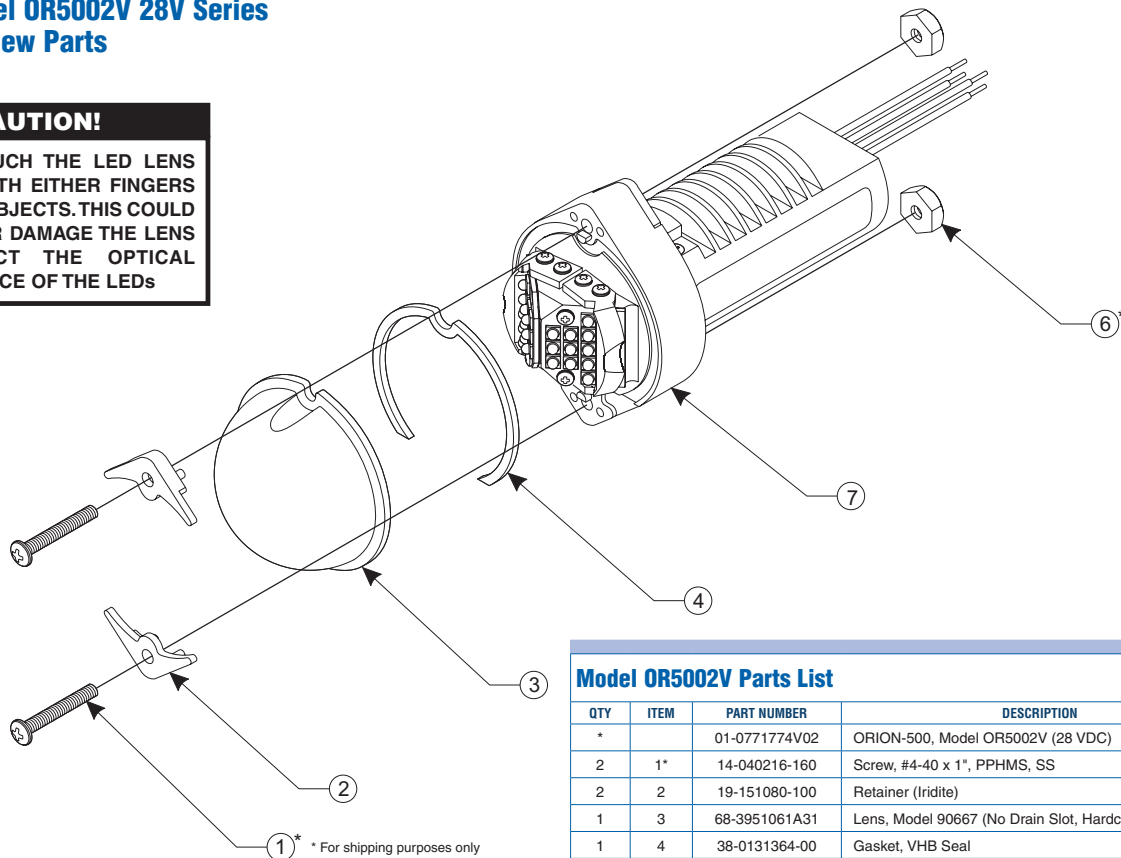

### Model OR5002V Parts List

QTY	ITEM	PART NUMBER	DESCRIPTION
*		01-0771774V02	ORION-500, Model OR5002V (28 VDC)
2	1*	14-040216-160	Screw, #4-40 x 1", PPHMS, SS
2	2	19-151080-100	Retainer (Iridite)
1	3	68-3951061A31	Lens, Model 90667 (No Drain Slot, Hardcoat)
1	4	38-0131364-00	Gasket, VHB Seal
1	7	01-0290717-01	Sub-Assy, ORION-500, Model OR5002V (28 VDC)
2	6*	13-040130-040	Nut, #4-40 x 1/4", Hex Brass



# ORION 650 LED LIGHT ASSEMBLIES

## MODELS OR6501G, OR6501R, OR6502G, OR6502R LED Wingtip Position / Anti-Collision Lighthouse Assembly

All LED self-contained wingtip mounted Position/Anti-Collision system. Eliminates the need for external power supplies and reduces current draw and provides thousands of hours of operation.



### Model OR650 Specifications

Model Numbers	Part Number	Voltage	LED Color	Anti-Collision LED Color	Operational Voltage	Input Current	Flash Rate	Weight	Approvals	Lenses
OR6501G	01-0790725-01	14 VDC	Aviation Green	Aviation White	11-15 VDC	0.20 (Position) 0.56 Amp Avg (Anti-Collision)	45 ± 5 FPM	0.3 lbs. (136gm)	FAA TSO/ETSO-C96a Class III / TSO/ETSO-C30c Type II	Clear Hard-coated Polycarbonate (Field Replaceable)
OR6501R	01-0790725-02		Aviation Red						FAA TSO/ETSO-C96a Class III / TSO/ETSO-C30c Type I	
OR6502G	01-0790725-11	28 VDC	Aviation Green		22-32 VDC	0.17 Amp (Position) .24 Amp Avg (Anti-Collision)			FAA TSO/ETSO-C96a Class III / TSO/ETSO-C30c Type II	
OR6502R	01-0790725-12		Aviation Red						FAA TSO/ETSO-C96a Class III / TSO/ETSO-C30c Type I	

## Operation

### EQUIPMENT LIMITATIONS:

An approved forward position lighting system consists of three lights, one located on the tail and one located on each wingtip. Model OR650( ) is a wingtip forward position and anti-collision light. The assembly should be mounted as far outboard on the aircraft as practical. The baseplate must be mounted parallel to the vertical and horizontal centerlines of the aircraft to project the patterns properly. Certain types of installations may require additional testing.

### CONTINUED AIRWORTHINESS:

The forward position light is designed with Green or Red LEDs. The anti-collision light is designed with 18 White LEDs. If any one LED fails, the unit must be repaired or replaced.

Inspect the lens, replace if there is excessive scratching, pitting, discoloration or cracking.

**Note:** To reduce eye strain, use an optical filter such as dark glasses or a Blue covering dome during LED inspection.

### INSTALLATION PROCEDURES:

The following information is to assist you in installing a Whelen light system.

1. Choose the appropriate light assembly.
2. Using the mounting detail information provided, prepare the aircraft for means to secure the light assembly.
3. Carefully remove the #4 phillips head screw and lens retainer. Remove the lens from the light assembly by lifting the rear of the lens approximately 1/2". Now slide the lens rearward approximately 1/4" and lift upwards to remove. **CAUTION! To avoid potential damage, do not touch the LEDs with either fingers or sharp objects.** Remove the 3 Phillips head screws securing the baseplate to the light assembly. Remove baseplate.
4. Using the appropriate hardware install the baseplate directly to the aircraft.
5. Route the wires through the opening in the baseplate. Connect the light inputs according to the chart shown. Connect the power lead to an appropriately sized breaker. Connections to be according to FAA approved methods. **Note:** SYNC is a low-power, bi-directional control signal. Connecting to the synchronize signal of any Whelen LED anticollision assembly to another Whelen anti-collision assembly will cause the lights to flash at the same time. If synchronization is not necessary, the connection may be left open.

## Operation (cont'd)

6. Re-install the light assembly on to the baseplate and insure that all leads are clear of any obstructions and secured as required. Note that proper orientation is achieved with the drain hole down.
7. Install lens in the reverse order as removal and return the lens retainer to its installed location. **Note: Visually confirm that the lens and retainer are fully and properly seated.** Re-insert #4 phillips head screw and tighten firmly.
8. When necessary, seal the light to the aircraft. Apply sealant around the perimeter of the base. Do not cover the drain hole.
9. Check all avionics systems for interference from this installation.
10. A flight check should be performed by a properly certified pilot.
11. Update aircraft records, complete Form 337 and obtain FAA field approval for installation, if required.

## Dimensions

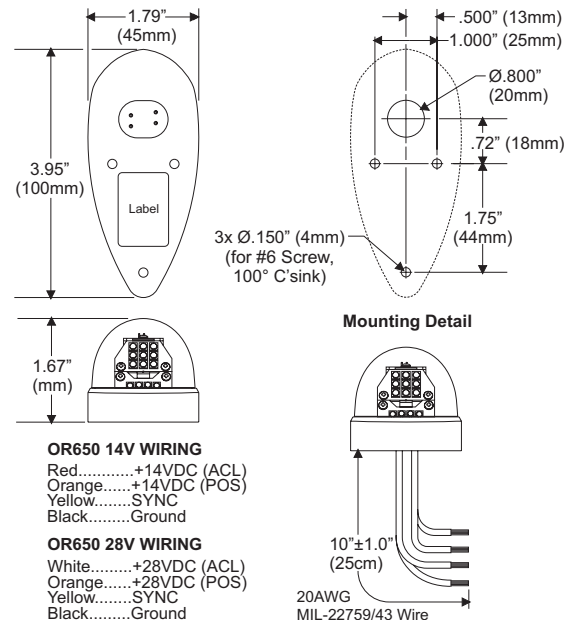

## Model OR6501G, OR6501R 14V Series Exploded View Parts

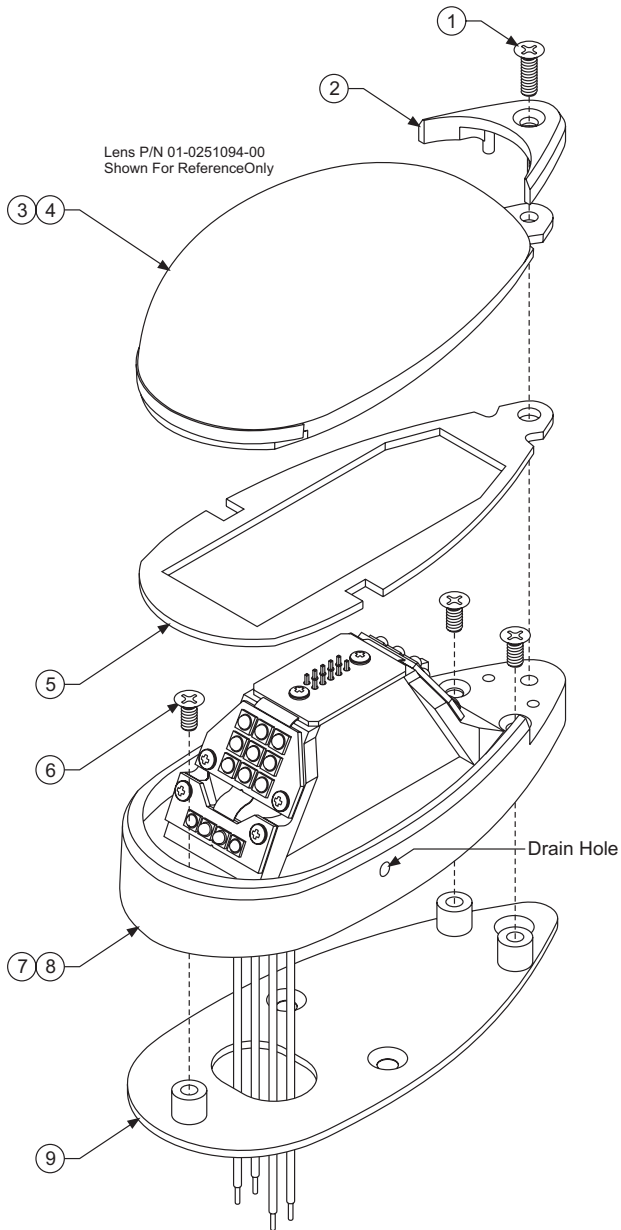

## Model OR6502G, OR6502R 28V Series Exploded View Parts

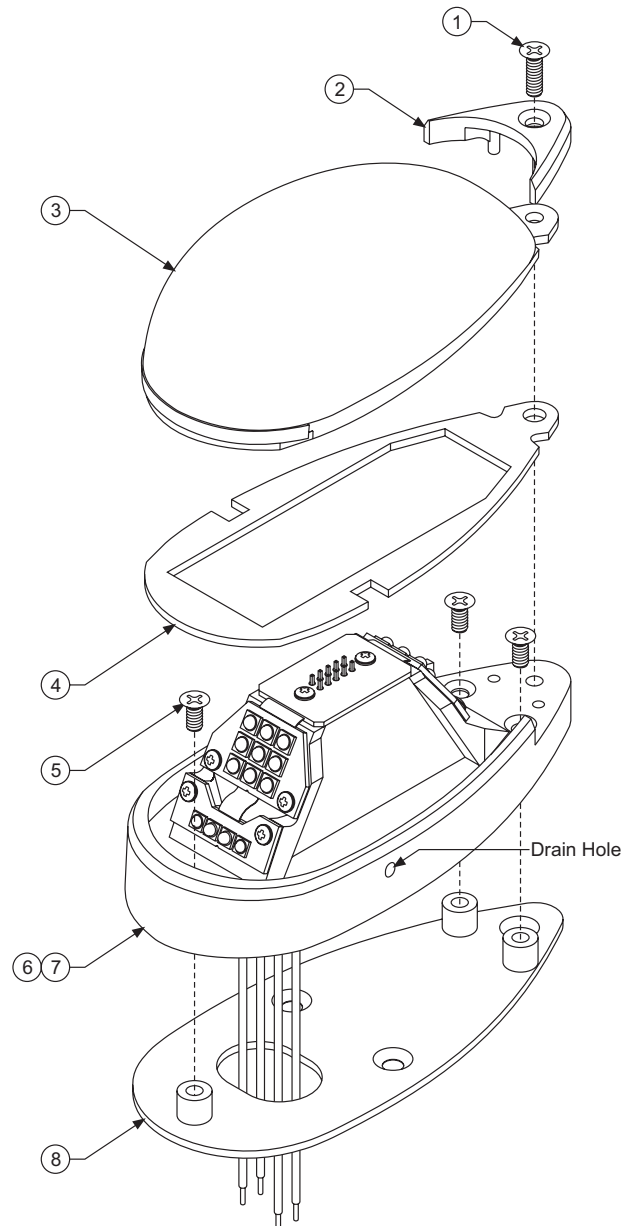

### Model OR6501G & OR6501R Series Parts List

QTY	QTY	ITEM	PART NUMBER	DESCRIPTION
—	*		01-0790725-01	OR6501G Wingtip Position/Anti-Collision Light, 14V (Green)
*	—		01-0790725-02	OR6501R Wingtip Position/Anti-Collision Light, 14V (Red)
1	1	1	14-0050581-05	Screw, #4-40 x 7/16, P100FH CSNK (MS24693-C5)
1	1	2	19-151088-000	Retainer, Lens, Model 90725
—	1	3	01-0251094-00	Lens-Assy, 2" Gasket
1	—	4	01-0251094-01	Lens-Assy, 1" Gasket
1	1	5	38-0231382-00	Gasket, Lens, Model 90725
3	3	6	14-0050581-02	Screw, #4-40 x 1/4, P100FH CSNK (MS24693-C2)
—	1	7	01-0290729-01	Sub-Assy, Model OR6501G, 14VDC Green
1	—	8	01-0290729-02	Sub-Assy, Model OR6501R, 14VDC Red
1	1	9	07-551089-100	Adapter, Mounting (Heli-Coils Installed, CMLP)

### Model OR6502G & OR6502R Series Parts List

QTY	QTY	ITEM	PART NUMBER	DESCRIPTION
—	*		01-0790725-11	OR6502G Wingtip Position/Anti-Collision Light, 28V (Green)
*	—		01-0790725-12	OR6502R Wingtip Position/Anti-Collision Light, 28V (Red)
1	1	1	14-0050581-05	Screw, #4-40 x 7/16, P100FH CSNK (MS24693-C5)
1	1	2	19-151088-000	Retainer, Lens, Model 90725
1	1	3	01-0251094-00	Lens-Assy, 2" Gasket
1	1	4	38-0231382-00	Gasket, Lens, Model 90725
3	3	5	14-0050581-02	Screw, #4-40 x 1/4, P100FH CSNK (MS24693-C2)
—	1	6	01-0290729-11	Sub-Assy, Model OR6502G, 28VDC Green
1	—	7	01-0290729-12	Sub-Assy, Model OR6502R, 28VDC Red
1	1	8	07-551089-100	Adapter, Mounting (Heli-Coils Installed, CMLP)

# ORION 650E LED LIGHT ASSEMBLIES

## MODELS OR6501GE, OR6501RE, OR6502GE, OR6502RE LED Wingtip Position / Anti-Collision Lighthouse Assembly

All LED self-contained wingtip mounted Position/Anti-Collision system. Eliminates the need for external power supplies and reduces current draw and provides thousands of hours of operation.



### Model OR650E Specifications

Model Numbers	Part Number	Voltage	LED Color	Anti-Collision LED Color	Operational Voltage	Input Current	Flash Rate	Weight	Approvals	Lenses
OR6501GE	01-0790701-01	12 VDC	Aviation Green	Aviation White	9-14 VDC	0.30 (Position) 0.7 Amp Avg (Anti-Collision)	45 ± 5 FPM	.26 lbs. (118gm)	FAA TSO/ETSO-C96a Class II / TSO/ETSO-C30c Type II	—
OR6501RE	01-0790701-02		Aviation Red						FAA TSO/ETSO-C96a Class II / TSO/ETSO-C30c Type I	
OR6502GE	01-0790701-11	28 VDC	Aviation Green		22-32 VDC	0.15 Amp (Position) .35 Amp Avg (Anti-Collision)			FAA TSO/ETSO-C96a Class II / TSO/ETSO-C30c Type II	
OR6502RE	01-0790701-12		Aviation Red						FAA TSO/ETSO-C96a Class II / TSO/ETSO-C30c Type I	

### Operation

#### EQUIPMENT LIMITATIONS:

An approved forward position lighting system consists of three lights, one located on the tail and one located on each wingtip. Model OR650( )E is a wingtip position and anti-collision light. The assembly should be mounted as far outboard on the aircraft as practical. The baseplate must be mounted parallel to the vertical and horizontal centerlines of the aircraft to project the patterns properly. This assembly must be mounted behind a Clear lens. Certain types of installations may require additional testing.

#### CONTINUED AIRWORTHINESS:

The forward position light is designed with Green or Red LEDs. The anti-collision light is designed with 24 white LEDs. If any one LED fails, the unit must be repaired or replaced. **Note:** To reduce eye strain, use an optical filter such as dark glasses or a Blue covering dome during LED inspection.

#### INSTALLATION PROCEDURES:

The following information is to assist you in installing a Whelen light system.

1. Choose the appropriate light assembly.
2. Using the mounting detail information provided, prepare the aircraft for means to secure the light assembly.
3. Carefully remove the #4 phillips head screw (qty. 4). Remove the light assembly from the baseplate. **CAUTION! Do not touch the LED with either fingers or sharp objects.** This could soil and/ or damage the lens and affect the optical performance of the LEDs.
4. Using the appropriate hardware install the baseplate to the aircraft.
5. Route the wires through the opening in the baseplate. Connect the light inputs according to the chart shown. Connect the power lead to an appropriately sized breaker. Connections to be according to FAA approved methods.
 

**Note:** SYNC is a low-power, bi-directional control signal. Connecting to the synchronize signal of any Whelen LED anticollision assembly to another Whelen anti-collision assembly will cause the lights to flash at the same time. If Synchronization is not necessary, the connection may be left open.
6. Re-install the light assembly on to the baseplate and insure that all leads are clear of any obstructions and secured as required.
7. Check all avionics systems for interference from this installation.

### Operation (cont'd)

8. A flight check should be performed by a properly certified pilot.
9. Update aircraft records, complete Form 337 and obtain FAA field approval for installation, if required.

### Dimensions and Mounting Detail

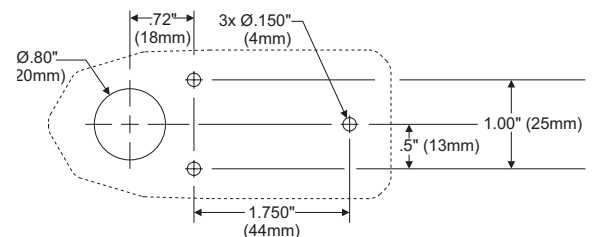

#### SUGGESTED MOUNTING DETAIL

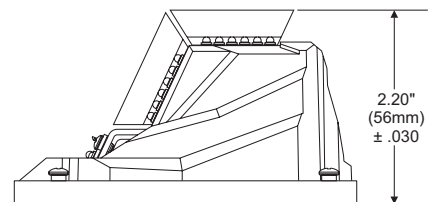
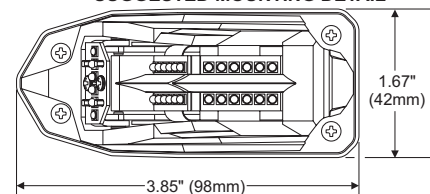

10.0" (25cm) ± 1.0"  
(20AWG MIL-22759/43)

12V WIRING CHART	
RED	12 VDC ACL
ORANGE	12 VDC POS
YELLOW	SYNC
BLACK	GROUND

28V WIRING CHART	
WHITE	28 VDC ACL
ORANGE	28 VDC POS
YELLOW	SYNC
BLACK	GROUND

**Model OR6501GE, OR6501RE 12V Series  
Exploded View Parts**

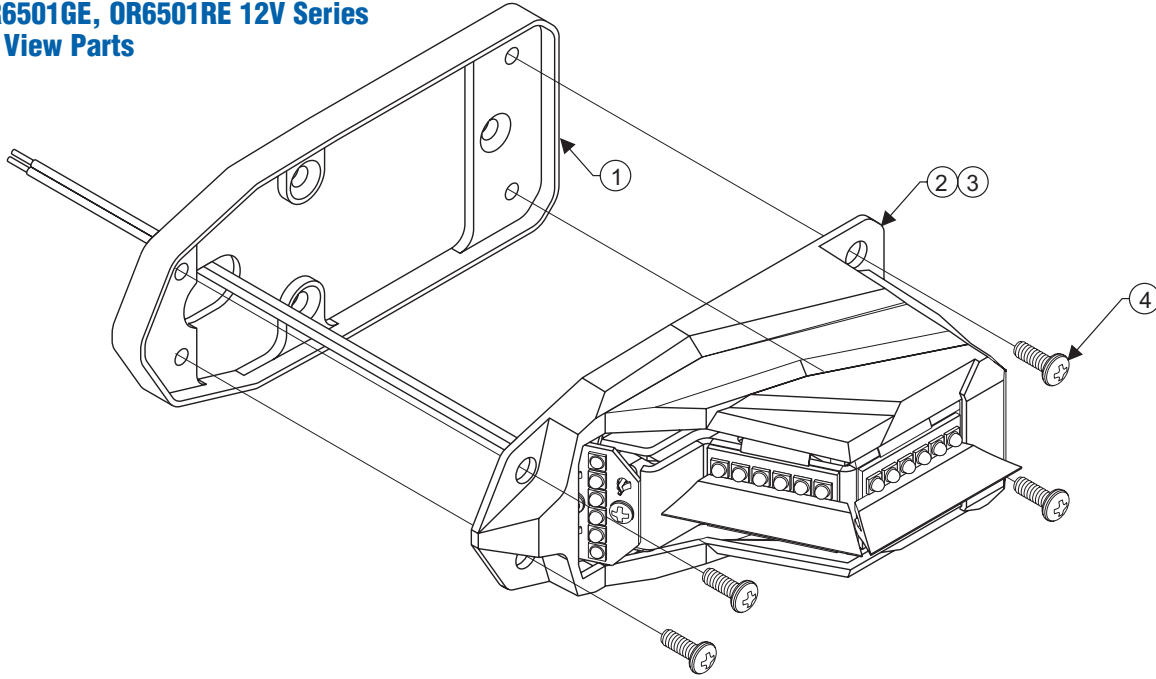

**Model OR6501GE, OR6501RE Series Parts List**

QTY	QTY	ITEM	PART NUMBER	DESCRIPTION
—	*	*	01-0790701-01	OR6501GE Wingtip Position/Anti-Collision Light, 12V (Green)
*	—	*	01-0790701-02	OR6501RE Wingtip Position/Anti-Collision Light, 12V (Red)
1	1	1	07-771790-100	Mounting Plate, Model 90701 (Heli-Coils, CMPL)
—	1	2	01-0290714-01	Sub-Assy, Model OR6501GE (12 VDC, GRN)
1	—	3	01-0290714-02	Sub-Assy, Model OR6501RE (12 VDC, RED)
4	4	4	14-0050505-14	Screw, #4-40 x 5/16, PPHMS (MS51957-14)

**Model OR6502GE, OR6502RE 28V Series  
Exploded View Parts**

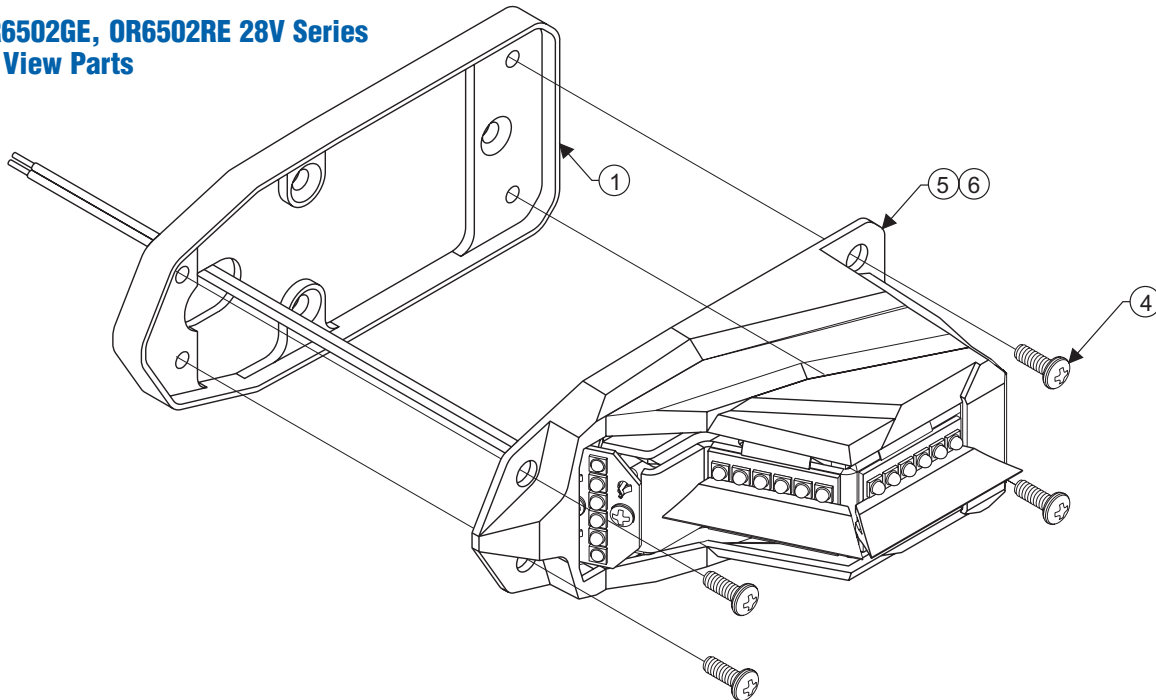

**Model OR6502GE, OR6502RE Series Parts List**

QTY	QTY	ITEM	PART NUMBER	DESCRIPTION
—	*	*	01-0790701-11	OR6502GE Wingtip Position/Anti-Collision Light, 28V (Green)
*	—	*	01-0790701-12	OR6502RE Wingtip Position/Anti-Collision Light, 28V (Red)
1	1	1	07-771790-100	Mounting Plate, Model 90701 (Heli-Coils, CMPL)
4	4	4	14-0050505-14	Screw, #4-40 x 5/16, PPHMS (MS51957-14)
—	1	5	01-0290714-11	Sub-Assy, Model OR6502GE (28 VDC, GRN)
1	—	6	01-0290714-12	Sub-Assy, Model OR6502RE (28 VDC, RED)







## MODEL A490TCF STROBE POWER SUPPLY

### FAA/PMA APPROVED

Model Number . . . . . A490TCF

Part Number . . . . . 01-0770006-08

## MODEL A490TCCF STROBE POWER SUPPLY

### FAA/PMA APPROVED

Model Number . . . . . A490TCCF

Part Number . . . . . 01-0770006-09

### Specifications (Both Models)

Current Draw . . . . . 1.7 Amps @ 14 VDC  
0.85 Amps @ 28 VDC

Weight . . . . . 1.2 lbs.

Length . . . . . 5.00"

Width . . . . . 3.12"

Height . . . . . 2.38"

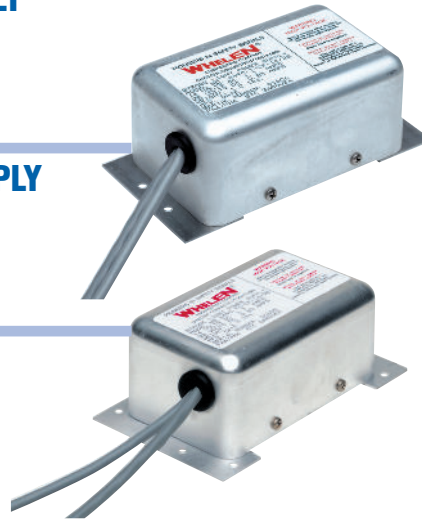

### Operation

**MODEL A490TCF:** This model operates one strobe lighthouse. It is our most compact unit and can be mounted in the wingtip and/or the tail adjacent to the lighthouse. It produces an accumulated 19 joules of power. It will only meet 400 ECP when used with the A470A-W. This unit can not be synchronized. This power supply operates from 10 to 30 volts DC. (Not approved for use with Red strobe light).



WHITE (+14/28 VDC)  
BLACK (GROUND)  
RED (ANODE) POSITION 1  
BLACK (CATHODE) POSITION 2  
WHITE (TRIGGER) POSITION 3

### Operation

**MODEL A490TCCF SERIES:** This model is the same as the A490TCF but has a mounting plate with additional holes that directly replaces factory installed systems on single engine Cessna's, Aero Commanders and Grumman Americans.



WHITE (+14/28 VDC)  
BLACK (GROUND)  
RED (ANODE) POSITION 1  
BLACK (CATHODE) POSITION 2  
WHITE (TRIGGER) POSITION 3

### Dimensions

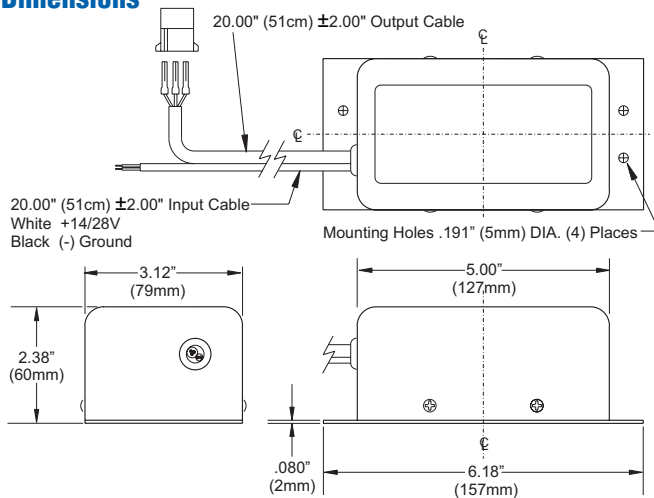

### Mounting

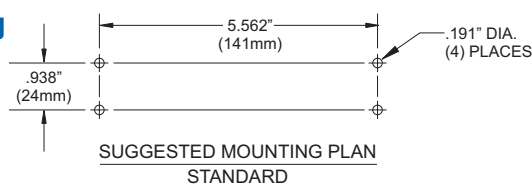

### Dimensions

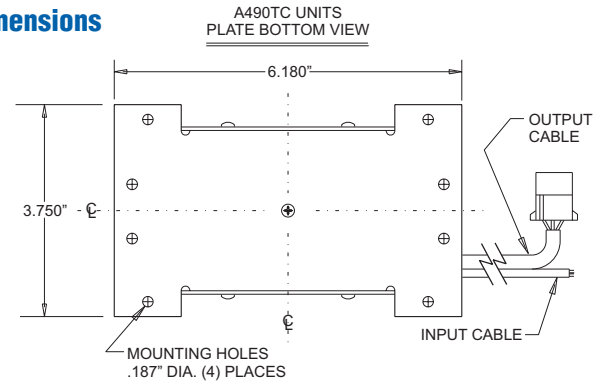

### Mounting

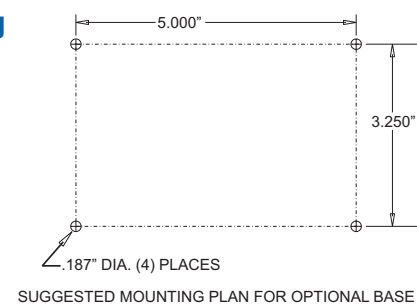

# LED LIGHT ASSEMBLIES

## MODEL OR36( ) SERIES LED FLASHING BEACON (Red & White LED's)

**TSO-C96a CLASS III APPROVED**

ORION 360 Beacons are the 4th Generation LED beacons for fixed wing aircraft. These are designed to replace legacy 2.6" and 3.75" round beacons. ORION 360 beacons are lower profile than legacy product by 60%. Please see documents for more information on this product.



### Model OR36( ) LED Flashing Beacon Specifications

Model Numbers	Part Number	Mount / Hole Pattern	Voltage	Lens	LED Color	Approvals	Input Current		Weight
OR36R1N	01-0772010-50	2.6" Base	14 VDC	Clear Polycarbonate	Red	TSO-C96a Class III	0.53 amps average	2.8 amps peak @.25 seconds	0.3 lbs. (136gm)
OR36R1W	01-0772010-52	3.67" Base			Red				0.37 lbs. (168gm)
OR36R2N	01-0772010-10	2.6" Base	28 VDC		Red		0.26 amps average	1.4 amps peak @.25 seconds	0.3 lbs. (136gm)
OR36R2W	01-0772010-12	3.67" Base			Red				0.37 lbs. (168gm)
OR36R2WL	01-0772010-13		Red		0.53 amps average		2.8 amps peak @.25 seconds	0.3 lbs. (136gm)	
OR36S1N	01-0772010-70	2.6" Base	14 VDC						Red / White
OR36S1W	01-0772010-72	3.67" Base	Red / White						
OR36S2N	01-0772010-30	2.6" Base	28 VDC		Red / White		0.26 amps average	1.4 amps peak @.25 seconds	0.3 lbs. (136gm)
OR36S2W	01-0772010-32	3.67" Base			Red / White				
OR36S2WL	01-0772010-33		Red / White		0.53 amps average		2.8 amps peak @.25 seconds	0.3 lbs. (136gm )	
OR36W2N	01-0772010-20	2.6" Base	White						0.37 lbs. (168gm)
OR36W2W	01-0772010-22	3.67" Base	White						
OR36W2WL	01-0772010-23		White						

### EQUIPMENT LIMITATIONS:

An approved Anti-Collision light assembly should be located so that their light will not impair the crews vision or detract from the conspicuity of the position lights. The baseplate must be mounted parallel to the vertical and horizontal centerlines of the aircraft to project the patterns properly.

Certain types of installations may require additional testing.

### AIRWORTHINESS LIMITATIONS:

The Airworthiness Limitations section is FAA approved and specifies inspections and other maintenance required under §43.16 and §91.403 of the Federal Aviation Regulations, unless an alternative program has been approved.

No airworthiness limitations are associated with the installation of the LED anti-collision light.

### CONTINUED AIRWORTHINESS:

Models OR36R2W, OR36R1W, OR36R2WL, OR36R1N and OR36R2N are designed with 20 red LEDs.

Models OR36S2W, OR36S1N, OR36S2WL, OR36S1W, and OR36S2N are designed with 10 red LEDs and 8 white LEDs.

Models OR36W2W, OR36W2N, and OR36W2WL are designed with 16 white LEDs. If any one LED fails the unit must be repaired or replaced.

**Note:** To reduce eye strain, use an optical filter such as dark glasses or a blue covering dome during LED inspection.

Inspect the lens. Replace if there is excessive surface deteriora-

tion, discoloration, crazing or cracking. For additional lens maintenance detail, see SAE ARP5637.

### PERIODIC INSPECTIONS:

An annual inspection shall be performed unless the OEM specifies a shorter interval.

### INSTALLATION PROCEDURES:

The following information provides guidelines for the installation of the WAT LED anti-collision light. Please refer to the OEM manual for your aircraft for specific removal and installation instructions.

1. Remove all electrical power or disable the applicable circuit breakers.
2. Using the mounting detail information provided, prepare the aircraft for means to secure the LED light assembly.
3. Connect the light inputs according to the chart shown. Connect the power lead to an appropriately sized breaker. Connections to be in accordance with FAA approved methods.
4. Using the appropriate hardware install the light assembly to the aircraft. Insure that all leads are clear of any obstructions and secured as required.
5. Enable applicable circuit breakers, place lighting switch in the ON position and verify proper operation of the WAT lights.
6. Check all avionics systems for interference from this installation.



## INSTALLATION PROCEDURES:

7. A flight check should be performed by a properly certified pilot.
8. If required, update aircraft records utilizing FAA Field Approval (Form 337) or equivalent.

## Models OR36R2W, OR36R2WL

### Exploded View Parts

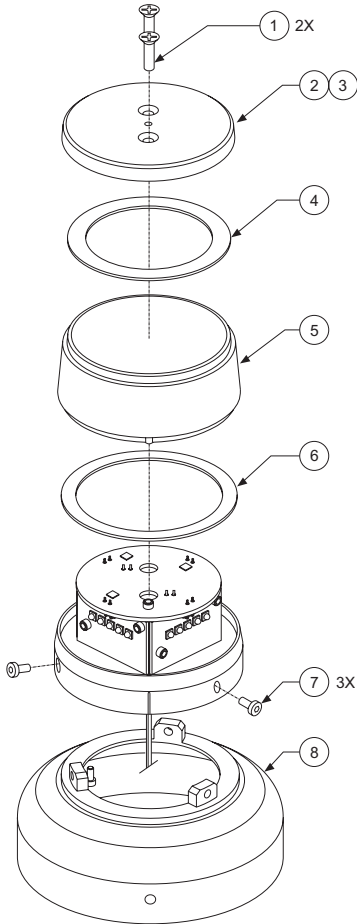

**Model OR36R2W & OR36R2WL1 Parts List**

QTY	QTY	ITEM	PART NUMBER	DESCRIPTION
*	*		01-0772010-12	MODEL, OR36R2W 28V UPPER RED 3.7" ACL
*	*		01-0772010-13	MODEL, OR36R2WL 28V LOWER RED 3.7" ACL
2	2	1	MS24693C28	SCREW, 6-32 X 1/2 P100FH/CSNK
1	—	2	22-0472012-01	CAP, LED A/C BEACON W/ DRAIN
—	1	3	22-0472012-00	CAP, LED A/C BEACON
1	1	4	38-0231522-01	GASKET, LENS UPPER 72010 BEACON
1	1	5	68-1972008A30	LENS, CLEAR OPTIC LED A/C BEACON HARD COAT
1	1	6	38-0231523-00	GASKET, LENS LOWER 72010 BEACON
3	3	7	14-040A20-05K	SCREW, 4-40 X 5/16" ALLEN SOCKET HD CAP
1	1	8	07-572032-100	PLATE, ADAPTER SIDE MOUNTING 72010 BEACON

### Mounting

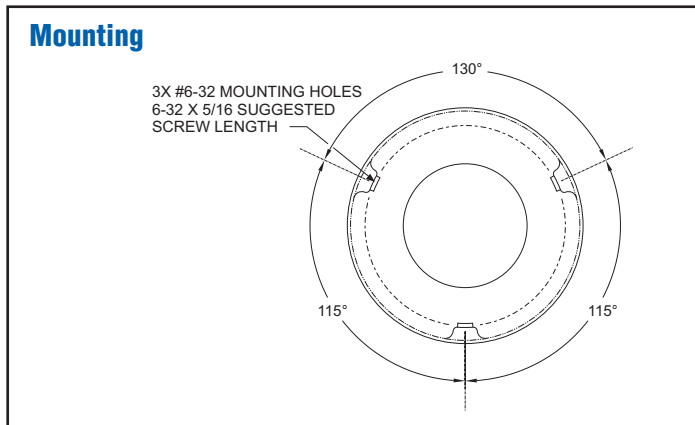

### Dimensions

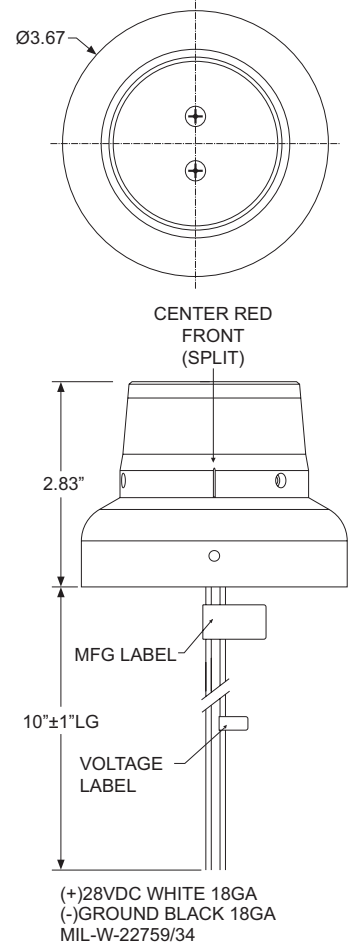

# Models OR36S2W, OR36S2WL

## Exploded View Parts

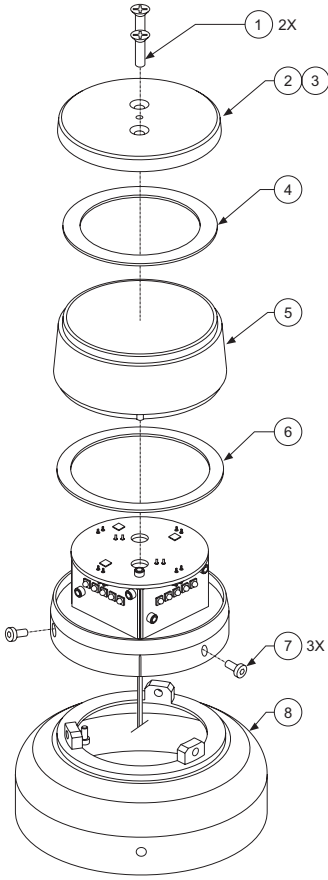

**Model OR36S2W & OR36S2WL Parts List**

QTY	QTY	ITEM	PART NUMBER	DESCRIPTION
	*		01-0772010-32	MODEL, OR36S2W 28V UPPER SPLIT 3.7" ACL
	*		01-0772010-33	MODEL, OR36S2WL 28V LOWER SPLIT 3.7" ACL
2	2	1	MS24693C28	SCREW, 6-32 X 1/2 P100FH/CSNK
1	—	2	22-0472012-01	CAP, LED A/C BEACON W/ DRAIN
—	1	3	22-0472012-00	CAP, LED A/C BEACON
1	1	4	38-0231522-01	GASKET, LENS UPPER 72010 BEACON
1	1	5	68-1972008A30	LENS, CLEAR OPTIC LED A/C BEACON HARD COAT
1	1	6	38-0231523-00	GASKET, LENS LOWER 72010 BEACON
3	3	7	14-040A20-05K	SCREW, 4-40 X 5/16" ALLEN SOCKET HD CAP
1	1	8	07-572032-100	PLATE, ADAPTER SIDE MOUNTING 72010 BEACON

## Mounting

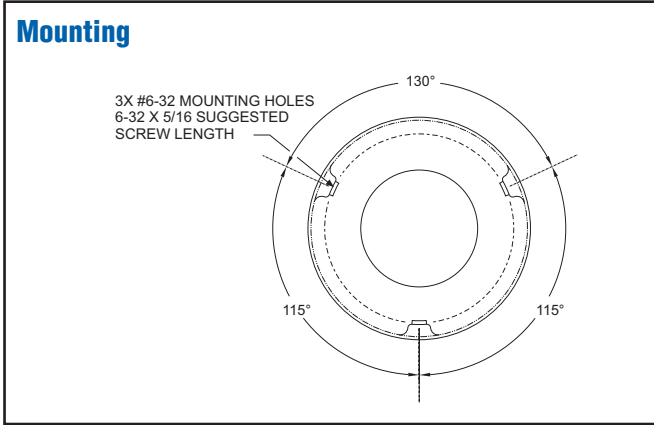

## Dimensions

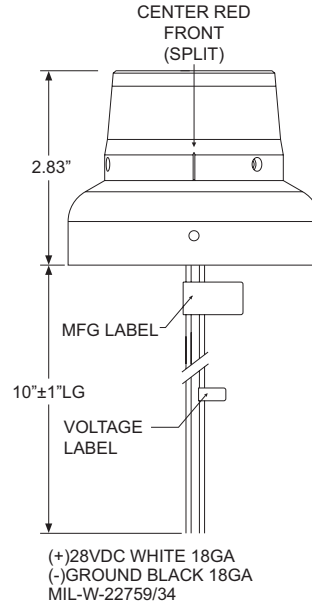
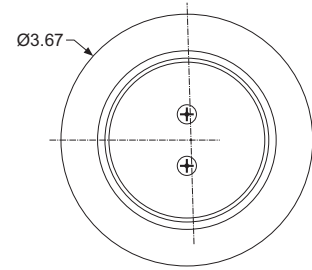

# Models OR36R1W, OR36S1W

## Exploded View Parts

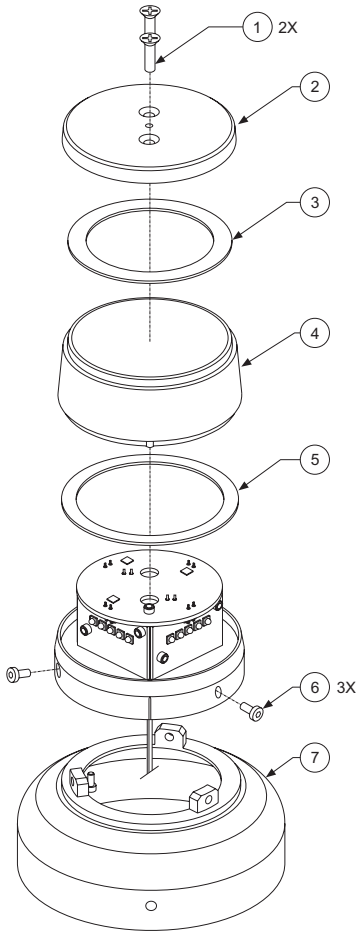

**Model OR36R1W & OR36S1W Parts List**

QTY	QTY	ITEM	PART NUMBER	DESCRIPTION
*	*		01-0772010-72	MODEL, OR36S1W 14V UPPER SPLIT 3.7" ACL
*	*		01-0772010-52	MODEL, OR36R1W 14V UPPER RED 3.7" ACL
2	2	1	MS24693C28	SCREW, 6-32 X 1/2 P100FH/CSNK
1	1	2	22-0472012-00	CAP, LED A/C BEACON
1	1	3	38-0231522-01	GASKET, LENS UPPER 72010 BEACON
1	1	4	68-1972008A30	LENS, CLEAR OPTIC LED A/C BEACON HARD COAT
1	1	5	38-0231523-00	GASKET, LENS LOWER 72010 BEACON
3	3	6	14-040A20-05K	SCREW, 4-40 X 5/16" ALLEN SOCKET HD CAP
1	1	7	07-572032-100	PLATE, ADAPTER SIDE MOUNTING 72010 BEACON

### Mounting

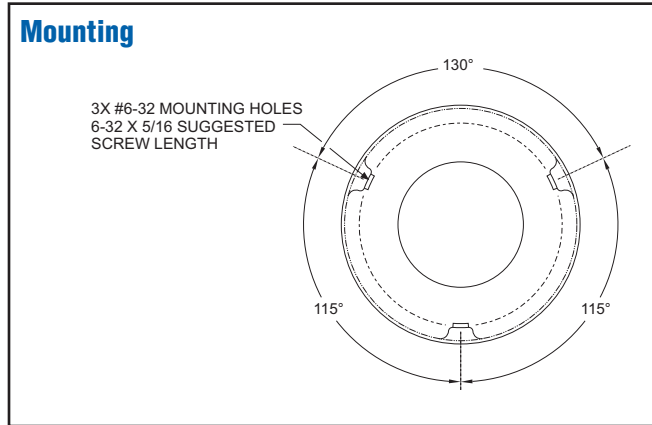

### Dimensions

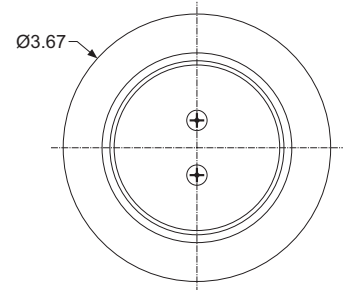

CENTER RED FRONT (SPLIT)

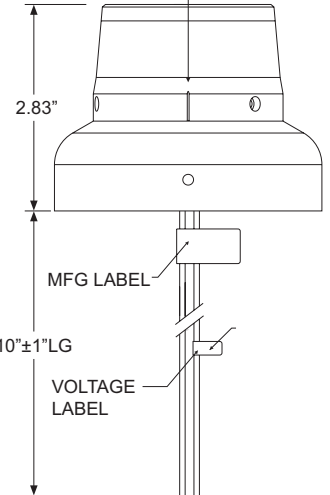

(+)14VDC RED 18GA  
 (-)GROUND BLACK 18GA  
 MIL-W-22759/34

# Models OR36W2W, OR36W2WL

## Exploded View Parts

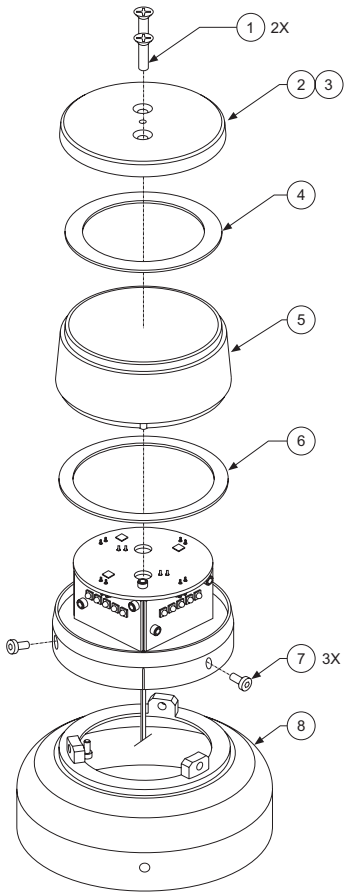

### Model OR36W2W & OR36W2WL Parts List

QTY	QTY	ITEM	PART NUMBER	DESCRIPTION
	*		01-0772010-22	MODEL, OR36W2W 28V UPPER WHITE 3.7" ACL
	*		01-0772010-23	MODEL, OR36W2WL 28V LOWER WHITE 3.7" ACL
2	2	1	MS24693C28	SCREW, 6-32 X 1/2 P100FH/CSNK
1	—	2	22-0472012-01	CAP, LED A/C BEACON W/ DRAIN
—	1	3	22-0472012-00	CAP, LED A/C BEACON
1	1	4	38-0231522-01	GASKET, LENS UPPER 72010 BEACON
1	1	5	68-1972008A30	LENS, CLEAR OPTIC LED A/C BEACON HARD COAT
1	1	6	38-0231523-00	GASKET, LENS LOWER 72010 BEACON
3	3	7	14-040A20-05K	SCREW, 4-40 X 5/16" ALLEN SOCKET HD CAP
1	1	8	07-572032-100	PLATE, ADAPTER SIDE MOUNTING 72010 BEACON

### Mounting

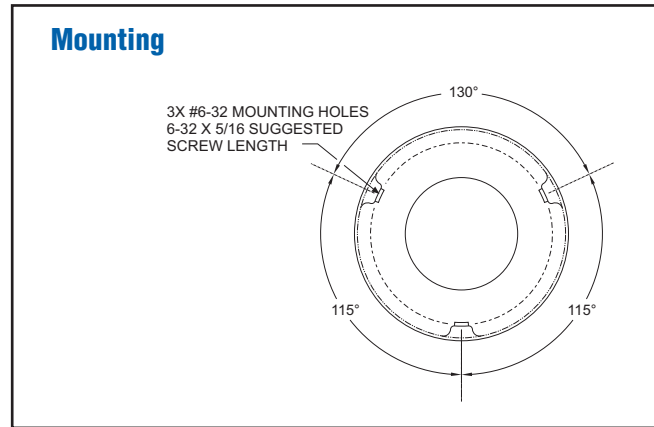

### Dimensions

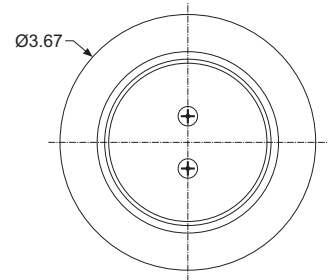

CENTER RED FRONT (SPLIT)

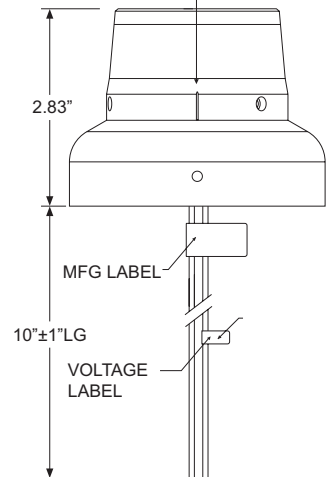

(+)28VDC WHITE 18GA  
 (-)GROUND BLACK 18GA  
 MIL-W-22759/34



# Models OR36R1N, OR36S1N Exploded View Parts

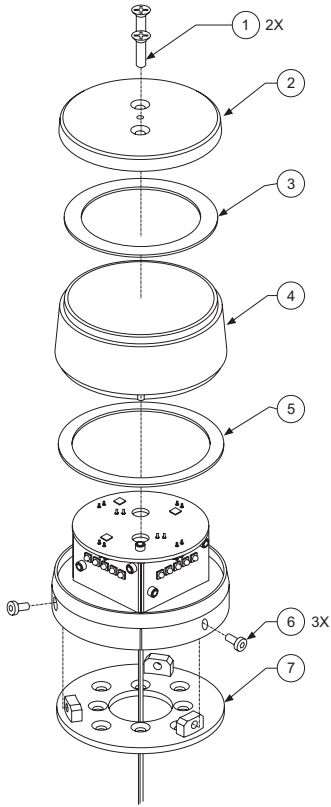

Model OR36R1N & OR36S1N Parts List				
QTY	QTY	ITEM	PART NUMBER	DESCRIPTION
	*		01-0772010-50	MODEL, OR36R1N 14V UPPER RED 2.6" ACL
	*		01-0772010-70	MODEL, OR36S1N 14V UPPER SPLIT 2.6" ACL
2	2	1	MS24693C28	SCREW, 6-32 X 1/2 P100FH/CSNK
1	1	2	22-0472012-00	CAP, LED A/C BEACON
1	1	3	38-0231522-01	GASKET, LENS UPPER 72010 BEACON
1	1	4	68-1972008A30	LENS, CLEAR OPTIC LED A/C BEACON HARD COAT
1	1	5	38-0231523-00	GASKET, LENS LOWER 72010 BEACON
3	3	6	14-040A20-05K	SCREW, 4-40 X 5/16" ALLEN SOCKET HD CAP
1	1	7	07-772031-100	PLATE, ADAPTER SIDE MOUNTING 72010 BEACON

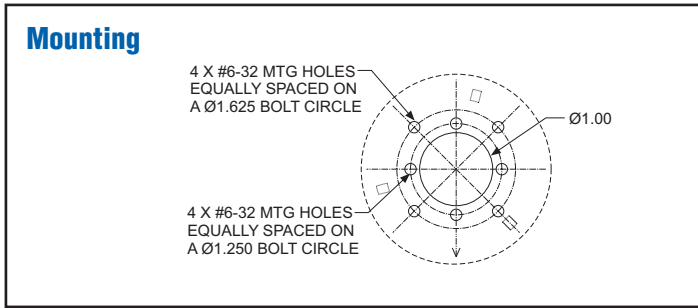

## Dimensions

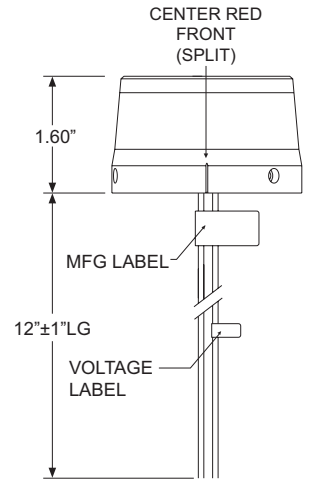
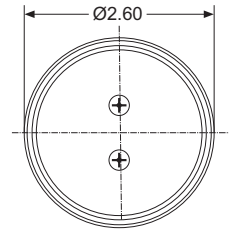

(+)14VDC RED 18GA  
 (-)GROUND BLACK 18GA  
 MIL-W-22759/34

# Models OR36R2N, OR36W2N, OR36S2N

## Exploded View Parts

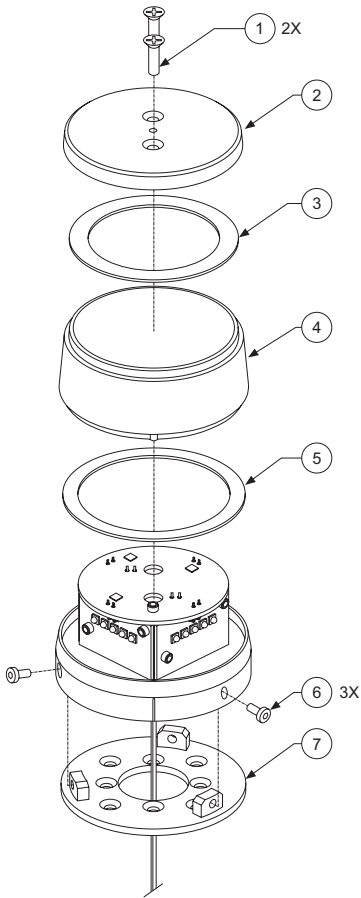

Model OR36R2N, OR36W2N & OR36S2N Parts List					
QTY	QTY	QTY	ITEM	PART NUMBER	DESCRIPTION
		*		01-0772010-10	MODEL, OR36R2N 28V UPPER RED 2.6" ACL
	*			01-0772010-20	MODEL, OR36W2N 28V UPPER WHITE 2.6" ACL
*				01-0772010-30	MODEL, OR36S2N 28V UPPER SPLIT 2.6" ACL
2	2	2	1	MS24693C28	SCREW, 6-32 X 1/2 P100FH/CSNK
1	1	1	2	22-0472012-00	CAP, LED A/C BEACON
1	1	1	3	38-0231522-01	GASKET, LENS UPPER 72010 BEACON
1	1	1	4	68-1972008A30	LENS, CLEAR OPTIC LED A/C BEACON HARD COAT
1	1	1	5	38-0231523-00	GASKET, LENS LOWER 72010 BEACON
3	3	3	6	14-040A20-05K	SCREW, 4-40 X 5/16" ALLEN SOCKET HD CAP
1	1	1	7	07-772031-100	PLATE, ADAPTER SIDE MOUNTING 72010 BEACON

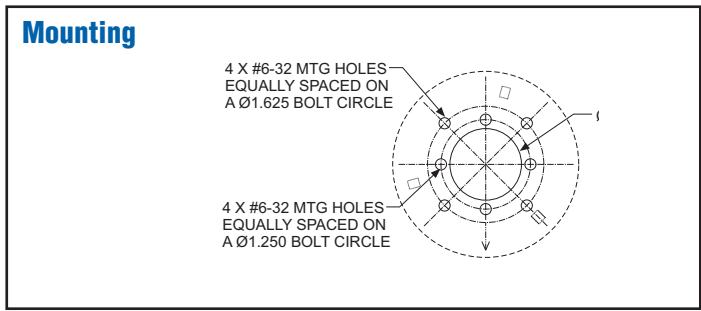

### Dimensions

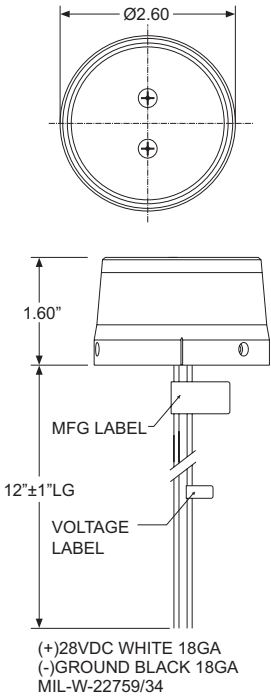

# LED LIGHT ASSEMBLIES

## CHROMA SERIES LED POSITION LAMPS

Meet all FAR requirements for Chromaticity, Intensity, and Coverage FAR Part 23.1383 the 23.1397 FAR Part 27.1383 thru 27.1397 Unique reflector design allows for full FAR coverage compliance. Fixed current source design provides consistent light output compared to filament lamps and LED resistor type designs = complete FAR compliance. Robust machined base provides vibration resistance tested in accordance with RTCA/DO160 CAT U2, Curves F, F1 for rotorcraft. All electronic logic conformal coated for weather resistance. Keeps original lens configuration to maintain FAA approvals of light assembly. LED lamps have a 10,000 hour operating life, while incandescent bulbs have a fragile filament and 300 hours average life 85% Reduced current draw Five year warranty FAA Approvals Pending O Ring allows for a more secure connection to lamp socket which reduces wear over time. Nickel Plated hard contact eliminates premature wear

TSO-C30c TYPE I & TYPE II APPROVED



### Model CHROMA LED Position Light

Model Numbers	Part Number	Voltage	Lens	LED Color	Approvals	Input Current	Weight
CHROMA1G	01-0771900G14	14 VDC	N/A	Green	TSO-C30b Type II	0.3 amps average	1. oz (28gm)
CHROMA1R	01-0771900R14			Red	TSO-C30b Type I		
CHROMA2G	01-0771900G28	28 VDC		Green	TSO-C30b Type II	0.13 amps average	
CHROMA2R	01-0771900R28			Red	TSO-C30b Type I		

### EQUIPMENT LIMITATIONS:

An approved forward position lighting system consists of two light assemblies, one located on each wingtip. The lamp must be installed in an appropriate lamp socket and behind a lens.

Certain types of installations may require additional testing.

### AIRWORTHINESS LIMITATIONS:

The Airworthiness Limitations section is FAA approved and specifies inspections and other maintenance required under §43.16 and §91.403 of the Federal Aviation Regulations, unless an alternative program has been FAA approved.

No airworthiness limitations are associated with the installation of the LED position lamp.

### CONTINUED AIRWORTHINESS:

The Chroma lamp is designed with multiple LEDs. If any one LED fails the unit must be repaired or replaced.

Note: To reduce eye strain, use an optical filter such as dark glasses or a blue covering dome during LED inspection.

### PERIODIC INSPECTIONS:

An annual inspection shall be performed unless the OEM manual specifies a shorter interval.

### INSTALLATION PROCEDURES:

The following information provides guidelines for the installation of the WAT LED Position Lamp. Please refer to the OEM manual for your aircraft for specific removal and installation instructions.

#### Removal

1. Remove all electrical power or disable the applicable circuit breakers.
2. Place the lighting switch in the OFF position.
3. Inspect the lens, retainer and attachment points for any signs of abnormal wear or damage.
4. Remove the lens, retainer and screw and put in a safe place.
5. Remove the lamp from the holder.

#### Installation

1. Remove all electrical power or disable the applicable circuit breakers.

2. Place the lighting switch in the OFF position.

3. Choose the appropriate replacement lamp assembly.

4. Examine the lamp socket. Make sure it is clean and free of foreign objects.

**CAUTION!** Do not touch the LEDs with either fingers or sharp objects as this could soil or damage the LEDs and affect the optical performance of the lamp.

5. Place the LED lamp into the holder ensuring the key (of the assembly) matches the key of the socket.

6. Reinstall the lens and secure using the retainers and screws. Note: Visually confirm that the lens, gasket and retainers are properly seated.

7. Enable applicable circuit breakers, place lighting switch in the ON position and verify proper operation of the Whelen lamps.

8. Check all avionics systems for interference from this installation.

9. A flight check should be performed by a properly certified pilot.

10. If required, update aircraft records utilizing FAA Field Approval

(Form 337) or equivalent.

### Exploded View Parts

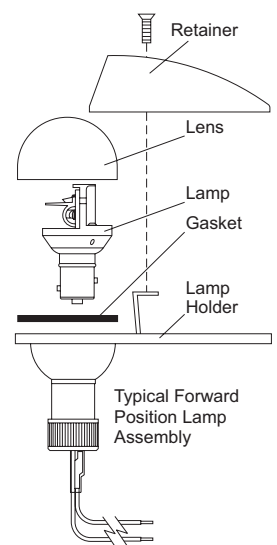

# LED LIGHT ASSEMBLIES

## MODEL 90520 ( ) SERIES LED FLASHING BEACON (Red & White LED's)

90520 series LED beacons are FAA TSO compliant self-contained LED anti-collision lights (Ref. Class III - 100 effective candlepower). They are designed to replace strobe lighthoods as small as the A470A with available models to replace HR self-contained beacons (HRCFA) or our legacy 70900 LED beacon. Mounting plate included with assembly. Refer to models and descriptions below.

### ELECTRICAL:

**Models:** 01, 04, 05, 14, 15, 51, 55: Ship with 12" Flying Leads

**Models:** 07, 17, 08, 18: MS3102R10SL-3P Connector

### MECHANICAL:

**Models:** 04, 14, 08, 18, 55 are 3-3/4" opening designed to fit inside an A440 mounting adapter, mounting designed to replace existing beacons utilizing a 5 Hole mounting pattern on 4.656" diameter bolt circle (Whelen 70285 series / 7090501 series or 70900 with A440 adapter).

**Models:** 05, 15, 07, 17 are 3-3/4" opening designed to fit inside an A440 mounting adapter, mounting holes to fit in place of rotating beacons, Whelen model HRCFA, or 7090004, 05 series LED beacons



9052001, 51

TSO-C96a CLASS III  
APPROVED



9052005, 15, 55

### Model 90520 ( ) LED Flashing Beacon Specifications

Model Numbers	Part Number	Mount / Hole Pattern	Voltage	Lens	LED Color	Approvals	Input Current		Weight		
9052001	01-0790520-01	A470A Mount / Flying Leads	28 VDC	Clear Polycarbonate	LED Red/White Beacon	FAA TSO-C96a Class III	0.67 amps average	3.0 amps peak @.3 seconds	0.6 lbs. (272gm)		
9052051	01-0790520-51	A470A Mount / Mate-N-Lock	14 VDC				1.34 amps average	6.0 amps peak @.3 seconds	0.65 lbs. (295gm)		
9052004	01-0790520-04	5 Hole Adapter / Flying Leads	28 VDC						0.67 amps average	3.0 amps peak @.3 seconds	0.8 lbs. (363gm)
9052014	01-0790520-14	5 Hole Adapter / Flying Leads, Lower									
9052005	01-0790520-05	3.75"Adapter / Flying Leads									
9052015	01-0790520-15	3.75"Adapter / Flying Leads, Lower									
9052007	01-0790520-07	3.75"Adapter / MSConn									
9052017	01-0790520-17	3.75"Adapter / MSConn, lower mount	0.75 lbs. (340gm)								
9052008	01-0790520-08	5 Hole Adapter / MSConn									
9052018	01-0790520-18	5 Hole Adapter / MSConn, lower mount									
9052055	01-0790520-55	3.75"Adapter / Flying Leads	14 VDC				1.34 amps average	6.0 amps peak @.3 seconds	0.75 lbs. (340gm)		

## Operation

The Model 90520 series LED Flashing Split Anti-Collision Light Assembly meets the requirements of FAR 91.205(c)(3).

**CONTINUED AIRWORTHINESS:** The 90520 series LED Flashing Split Anti-Collision Light Assembly is designed with 4 vertical columns consisting of 4 red LEDs each and 4 vertical columns consisting of 3 white LEDs each. Should any one LED or any vertical column fail, the unit must be repaired or replaced. Inspect the lens and replace if there is excessive scratching, discoloration or cracking.

**INSTALLATION PROCEDURES:** The following information is to assist in the installation of a Whelen LED Flashing Split Anti-collision Light System.

1. The installation procedure described in the following text will be confined to a single light installation, but is identical for multiple light installations.
2. Using the "suggested mounting hole pattern" prepare the aircraft for means to secure the LED Flashing Split Anti-collision Light assembly. Remove any existing mounting adapters.

3. 14 or 28 VDC (+) and (-) ground leads equipped with an appropriate sized breaker to be supplied to the LED Flashing Split Anti-Collision Light Assembly System. Both leads must be connected by an approved FAA connection. Insure that the wire leads are clear of any obstructions and ty-wrap as required.
4. Install the light assembly by securing to the aircraft using appropriate, approved hardware. Refer to page 2.
5. All inverted (bottom) mounted units shall require waterproofing of the flasher base assembly to the aircraft.
6. Check all avionics systems for interference from this installation.
7. A flight check should be performed by a properly certified pilot.
8. Update aircraft records, as required. Update aircraft records, complete Form 337 and obtain FAA field approval for installation, **if not covered under STC eligibility list.**



# Models 9052001, 9052051

## Exploded View Parts

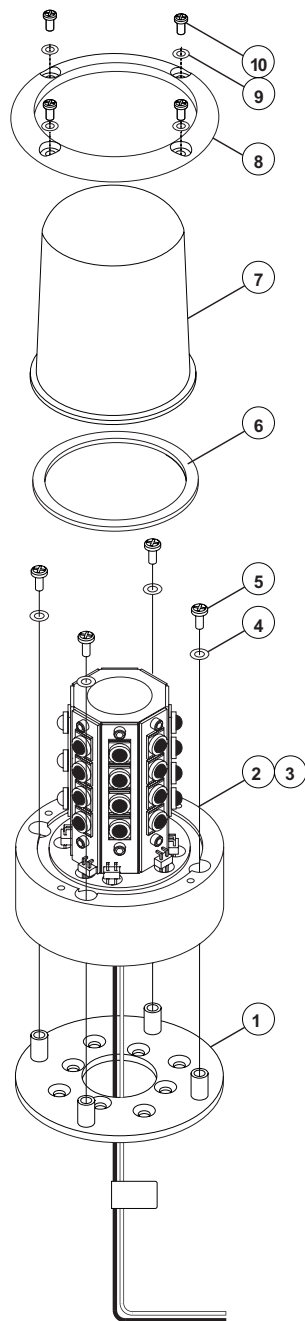

### Model 9052001 & 9052001 Parts List

QTY	QTY	ITEM	PART NUMBER	DESCRIPTION
—	*		01-0790520-01	Model 9052001 (28V)
*	—		01-0790520-51	Model 9052051 (14V)
1	1	1	07-771051-100	Adapter Plate, 8 Hole
—	1	2	01-0290522-00	Assy, 28V
1	—	3	01-0290522-50	Assy, 14V
4	4	4	16-0050506136	Washer, #6 Lock-Spring MS35338-136
4	4	5	14-0050503-30	Screw, 6-32 X 1/2 PPHMS SS MS51957-30
1	1	6	38-0250885-00	Gasket, Lens
1	1	7	68-4971082A30	Lens, Clear
1	1	8	19-171047-100	Retainer, Lens
4	4	9	16-0050506135	Washer, #4 Lock-Spring MS35338-135
4	4	10	14-0050505-14	Screw, 4-40 X 5/16 PPHMS MS51957-14

### Mounting

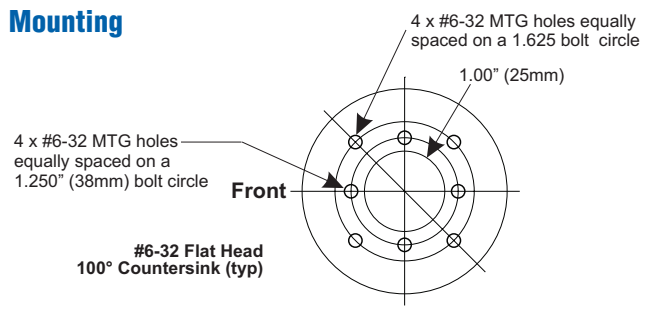

### Dimensions

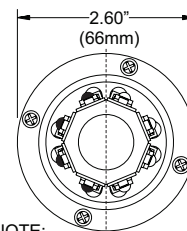

NOTE:  
RED LEDs TO THE FRONT

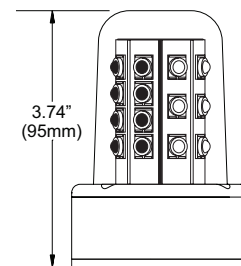

MFG LABEL

BLACK (-) GROUND  
(28VDC) 18AWG 12" ±1.0"  
(14VDC) 20AWG 6.0" ±1.0"

WHITE (+) 28VDC  
18AWG 12" ±1.0"

RED (+) 14VDC  
20AWG 6" ±1.0"

# Models 9052004, 9052014

## Exploded View Parts

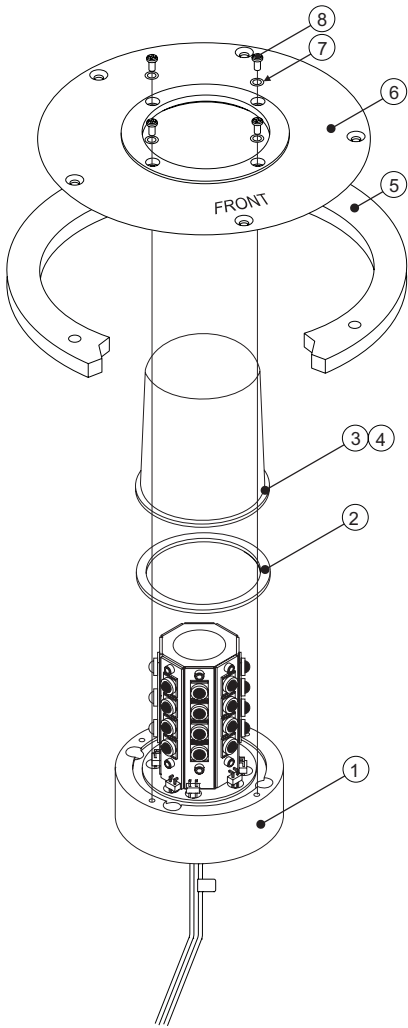

### Model 9052004 & 9052014 Parts List

QTY	QTY	ITEM	PART NUMBER	DESCRIPTION
—	*		01-0790520-04	Model 9052004 (28V) Upper
*	—		01-0790520-14	Model 9052014 (28V) Lower
1	1	1	01-0290522-00	Assy, 28V
1	1	2	38-0250885-00	Gasket, Lens
—	1	3	68-4971082A30	Lens, Clear
1	—	4	68-4971082A31	Lens, Clear
1	1	5	38-0250225-00	Seal
1	1	6	07-571304-100	Adapter, 5-Hole Lens Retainer
4	4	7	16-0050506135	Washer, #4 Lock-Spring MS35338-135
4	4	8	14-0050505-14	Screw, 4-40 X 5/16 PPHMS MS51957-14

### Dimensions

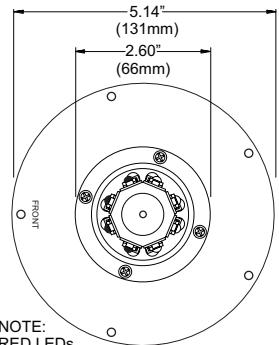

NOTE:  
RED LEDs  
TO THE FRONT

### Mounting

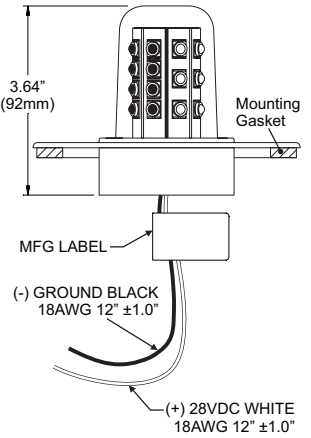
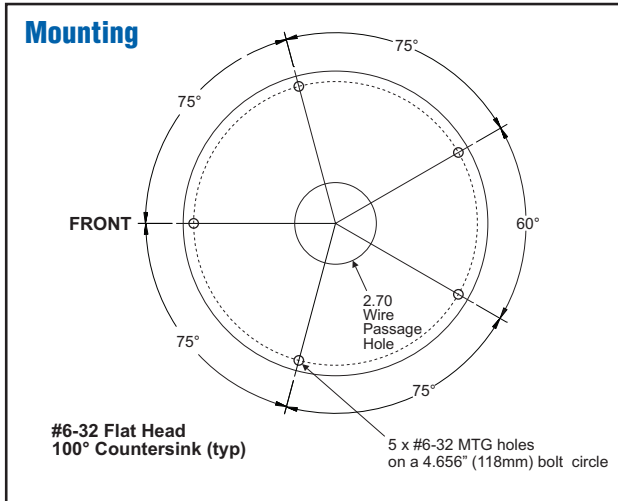

# Models 9052005, 9052015, 9052055

## Exploded View Parts

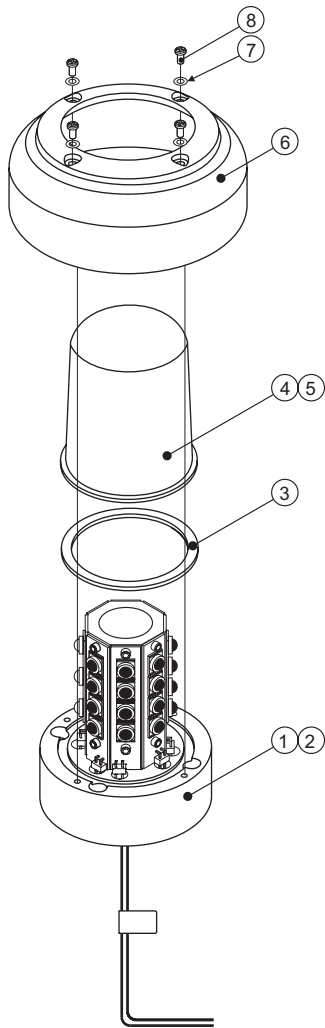

QTY	QTY	QTY	ITEM	PART NUMBER	DESCRIPTION
—	—	*		01-0790520-05	Model 9052005 (28V) Upper
—	*	—		01-0790520-15	Model 9052015 (28V) Lower
*	—	—		01-0790520-55	Model 9052055 (14V) Upper
1	1	1	1	01-0290522-00	Assy, 28V
—	—	1	2	01-0290522-50	Assy, 14V
1	1	1	3	38-0250885-00	Gasket, Lens
—	—	1	4	68-4971082A30	Lens, Clear
1	1	—	5	68-4971082A31	Lens, Clear
1	1	1	6	07-571361-100	Adapter, Mounting
4	4	4	7	16-0050506135	Washer, #4 Lock-Spring MS35338-135
4	4	4	8	14-0050505-14	Screw, 4-40 X 5/16 PPHMS MS51957-14

## Dimensions

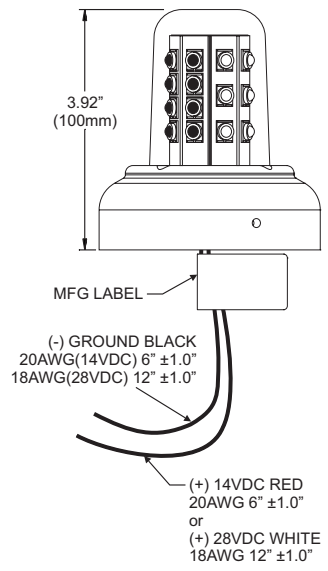
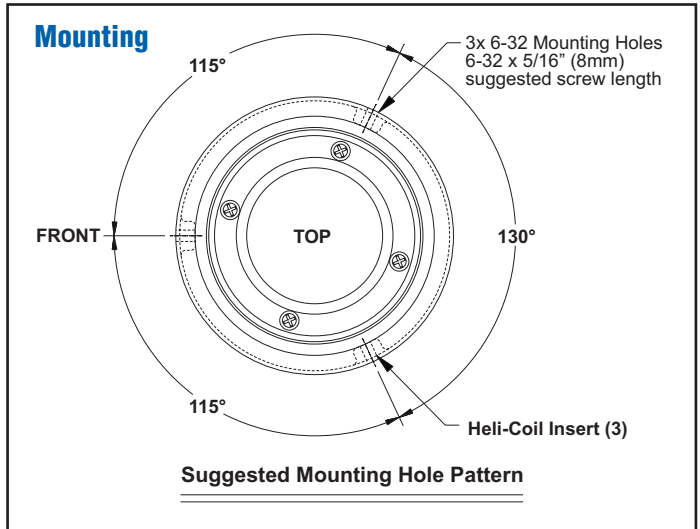
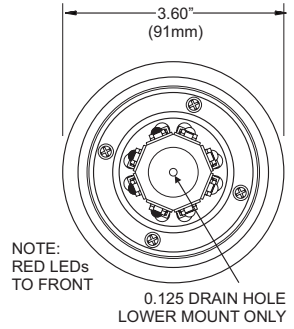

# Models 9052007, 9052017

## Exploded View Parts

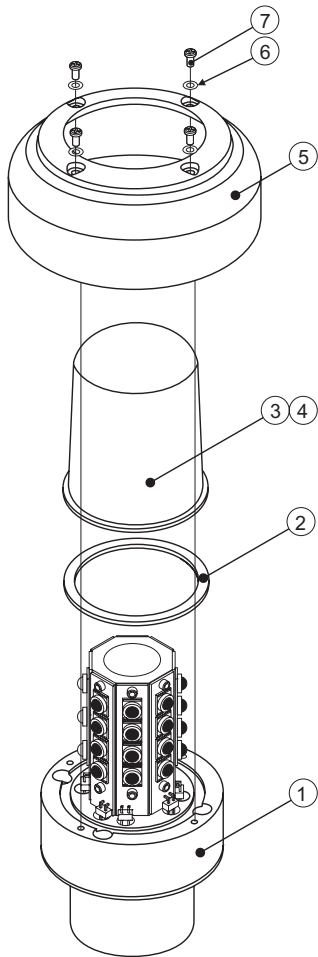

QTY	QTY	ITEM	PART NUMBER	DESCRIPTION
—	*		01-0790520-07	Model 9052007 (28V) Upper
*	—		01-0790520-17	Model 9052017 (28V) Lower
1	1	1	01-0290522-00	Assy, 28V
1	1	2	38-0250885-00	Gasket, Lens
—	1	3	68-4971082A30	Lens, Clear
1	—	4	68-4971082A31	Lens, Clear
1	1	5	07-571361-100	Adapter, Mounting
4	4	6	16-0050506135	Washer, #4 Lock-Spring MS35338-135
4	4	7	14-0050505-14	Screw, 4-40 X 5/16 PPHMS MS51957-14

## Dimensions

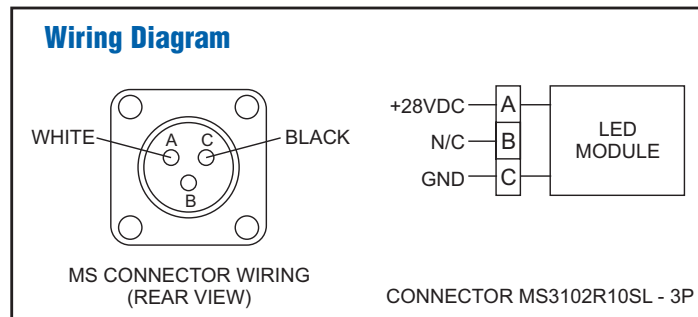
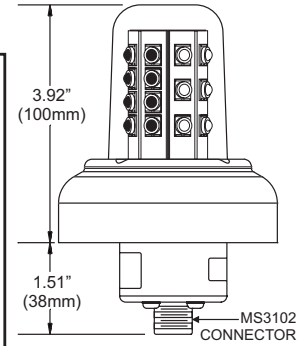
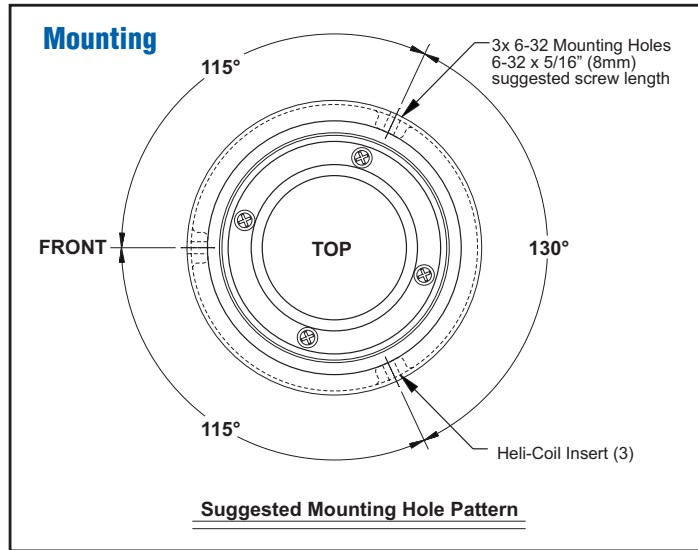
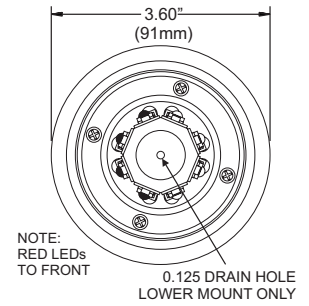

# Models 9052008, 9052018

## Exploded View Parts

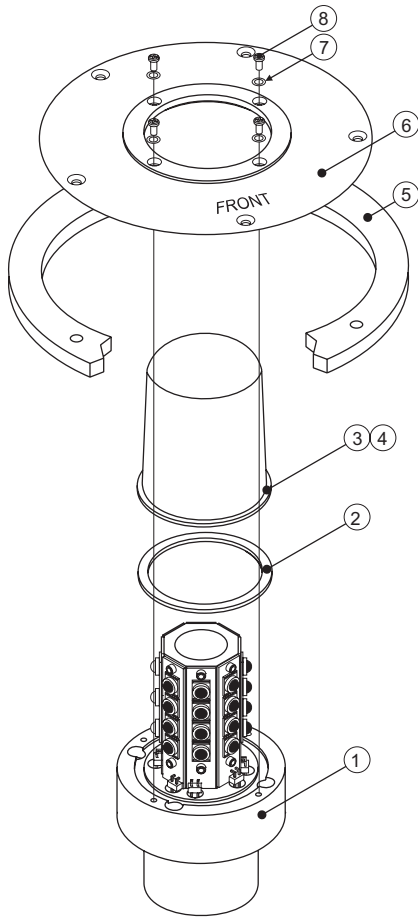

QTY	QTY	ITEM	PART NUMBER	DESCRIPTION
—	*		01-0790520-08	Model 9052008 (28V) Upper
*	—		01-0790520-18	Model 9052018 (28V) Lower
1	1	1	01-0290522-00	Assembly, 28V
1	1	2	38-0250885-00	Gasket, Lens
—	1	3	68-4971082A30	Lens, Clear
1	—	4	68-4971082A31	Lens, Clear with Drain
1	1	5	38-0250225-00	Seal
1	1	6	07-571304-100	Adapter, 5-Hole Lens Retainer
4	4	7	16-0050506135	Washer, #4 Lock-Spring MS35338-135
4	4	8	14-0050505-14	Screw, 4-40 X 5/16 PPHMS MS51957-14

## Dimensions

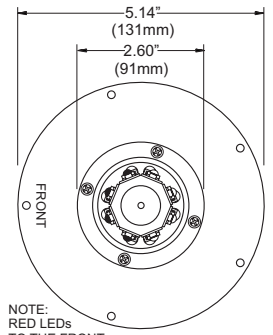

NOTE:  
RED LEDs  
TO THE FRONT

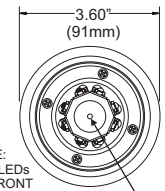
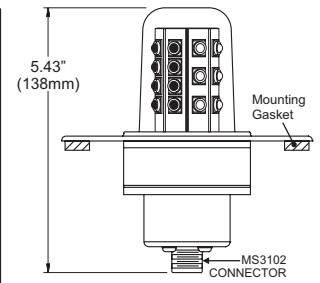
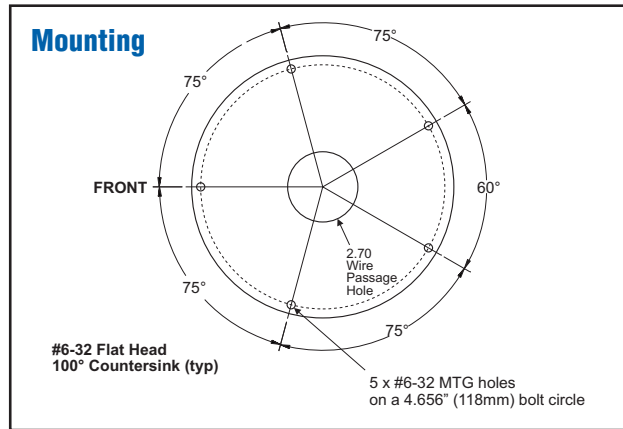

NOTE:  
RED LEDs  
TO FRONT

0.125 DRAIN HOLE  
LOWER MOUNT ONLY

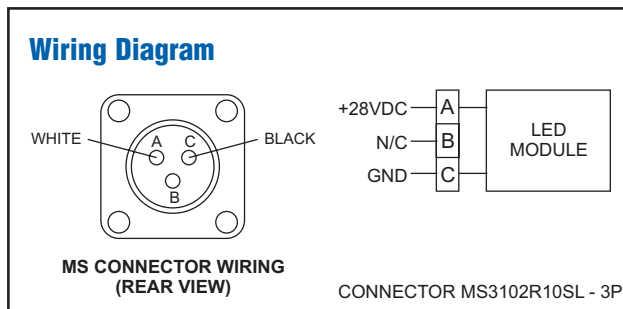



# LED LIGHT ASSEMBLIES

## MODEL 71080 ( ) SERIES LED BEACON (Red LED's) LED Flashing Anti-Collision Light Assembly (150 eff. Cd) (14 VDC & 28 VDC)

71080 series LED beacons are FAA TSO compliant Self-Contained LED Anti-Collision lights (Ref. Class I - 150 effective candlepower). They are designed to replace a range of products. Refer to models and descriptions below.

**ELECTRICAL, Models:** 01, 04, 05, 14, 15, 20, 51, 55: Ship with 12" Flying Leads  
**Models:** 07, 17, 08, 18: MS3102R10SL-3P Connector

**MECHANICAL, Models:** 04, 14, 08, 18 are designed to replace existing beacons utilizing a 5-Hole mounting pattern on a 4.656 diameter bolt circle (Whelen 70285 series/7090501 series or 70900 with A440 adapter).

**Models:** 05, 15, 07, 17 are 3 3/4" opening designed to fit inside an A440 mounting adapter, mounting holes to fit in place of rotating beacons, Whelen Model HRCFA, or 7090004, 05 series LED beacons



### Model 71080 ( ) LED Rotorcraft Beacon Specifications

Model Numbers	Part Number	Mount / Hole Pattern	Voltage	Lens / LED Color	Approvals	Input Current		Weight		
7108001	01-0771080-01	A470A Mount	28 VDC	Clear polycarbonate hard-coat LED Red	FAA TSO-C96a Class I & III (150 ecp)	0.45 amps average	2.0 amps peak	0.65 lbs. (295gm)		
7108004	01-0771080-04	5 Hole Adapter, Flying Leads			FAA TSO-C96a Class I			0.80 lbs. (363gm)		
7108005	01-0771080-05	3.75" Adapter, Flying Leads			FAA TSO-C96a Class I & III (150 ecp)			0.75 lbs. (340gm)		
7108006	01-0771080-06	A470A Mount			FAA TSO-C96a Class I (150 ecp)			0.65 lbs. (295gm)		
7108007	01-0771080-07	3.75" Adapter, MSConn, Lower			FAA TSO-C96a Class I & III (150 ecp)			0.87 lbs. (395gm)		
7108008	01-0771080-08	5 Hole Adapter, MSConn						0.80 lbs. (363gm)		
7108014	01-0771080-14	5 Hole Adapter, Flying Leads, Lower			14 VDC	Clear polycarbonate hard-coat LED Red	FAA TSO-C96a Class I	0.45 amps average	2.0 amps peak	0.75 lbs. (340gm)
7108015	01-0771080-15	3.75" Adapter, Flying Leads, Lower					FAA TSO-C96a Class I & III (150 ecp)			0.87 lbs. (395gm)
7108017	01-0771080-17	3.75" Adapter, MSConn, Lower					FAA TSO-C96a Class I			0.75 lbs. (340gm)
7108018	01-0771080-18	5 Hole Adapter, MSConn, Lower								0.87 lbs. (395gm)
7108020	01-0771080-20	EC120, 130, 135 Adapter					FAA TSO-C96a Class I	0.75 lbs. (340gm)		
7108030	01-0771080-30	EC120, 130, 135 Adapter, MSConn						0.87 lbs. (395gm)		
7108051	01-0771080-51	A470A Mount, Mate-N-Lock	FAA TSO-C96a Class I & III (150 ecp)	0.90 amps average			4.0 amps peak	0.65 lbs. (295gm)		
7108055	01-0771080-55	3.75" Adapter, Flying Leads						0.75 lbs. (340gm)		

### Operation

The Model 71080 series LED Anti-Collision light assembly meets the requirements of FAR 91.205(c)(3).

**CONTINUED AIRWORTHINESS:** The 71080 series LED anti-collision light assembly is designed with 8 vertical columns consisting of 4 LEDs each. Should any one LED or any vertical column fail, the unit must be repaired or replaced. Inspect the lens and replace if there is excessive scratching, discoloration or cracking.

**INSTALLATION PROCEDURES:** The following information is to assist in the installation of a Whelen LED Flashing Anti-collision Light System.

1. The installation procedure described in the following text will be confined to a single light installation, but is identical for multiple light installations.
2. Using the "suggested mounting hole pattern" prepare the aircraft for means to secure the LED Flashing Anti-Collision Light assembly. Remove any existing mounting adapters.
3. 28 VDC (+) and (-) ground leads equipped with an appropriate sized breaker to be supplied to the LED Flashing Anti-Collision Light Assembly System. Both leads must be connected by an

approved FAA connection. Insure that the wire leads are clear of any obstructions and ty-wrap as required.

4. Install the light assembly by first removing the lens. Remove the adapter plate. Attach the adapter plate to the aircraft mounting holes. Refer to page 2. Reinstall the light assembly and lens.
5. All inverted (bottom) mounted units shall require waterproofing of the flasher base assembly to the aircraft. **Note:** Drill a 1/8" hole in the center of the lens for bottom mount units.
6. Check all avionics systems for interference from this installation.
7. A flight check should be performed by a properly certified pilot.
8. Update aircraft records, as required & obtain FAA field approval for installation, **if not covered under STC eligibility list.**

### Model 71080 Series

Class I helicopter beacon (Red only), can now replace Model 70905 beacon, now available with new style mounts and electrical connections (28 & 14 VDC).

# Models 7108001, 7108006, 7108051

## Exploded View Parts

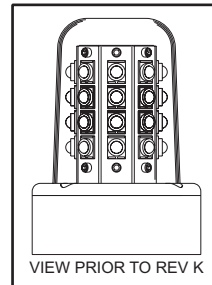
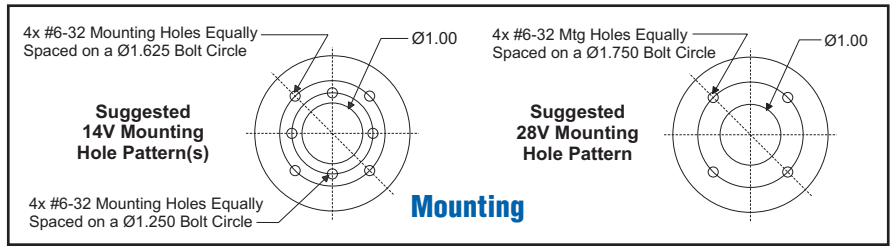
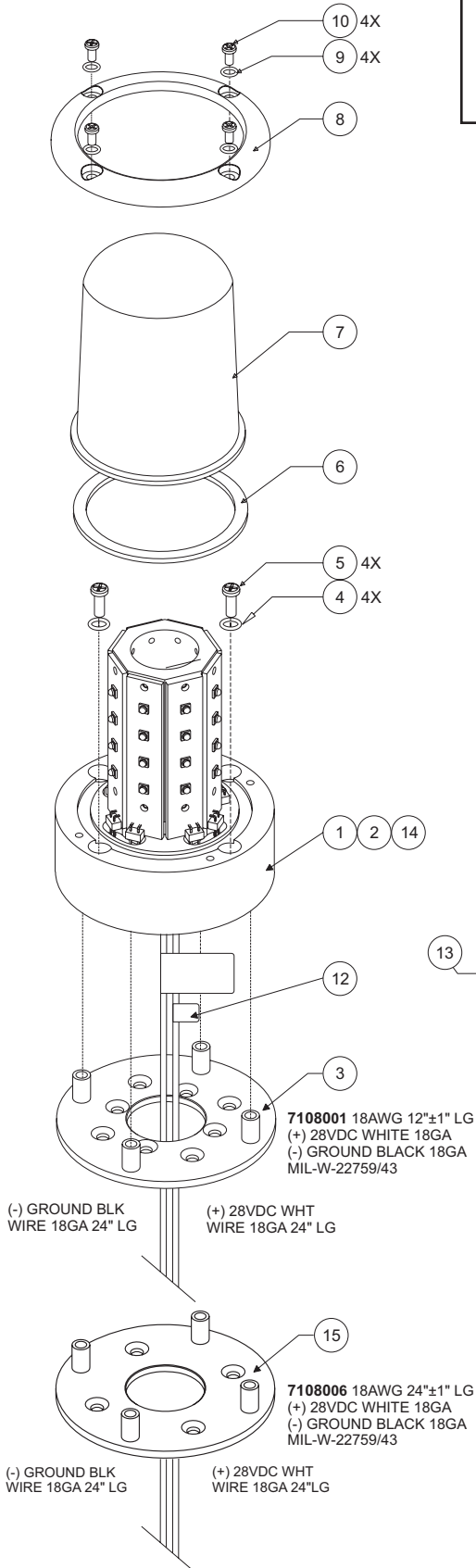

## Dimensions

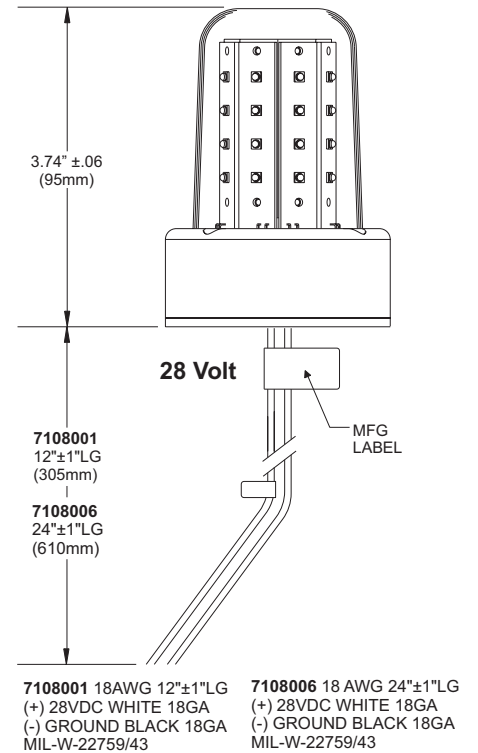
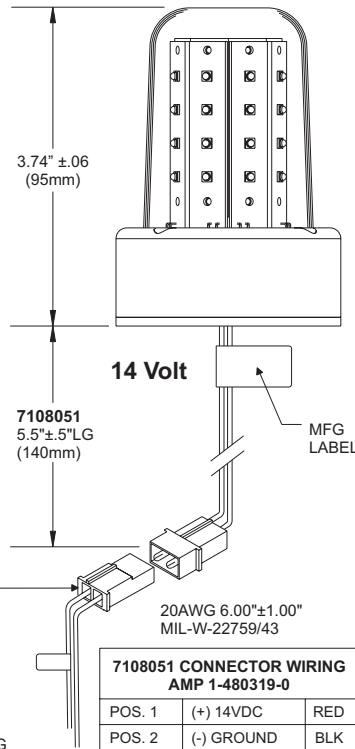
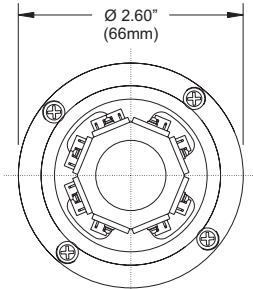

## Model 71080( ) Series Parts List

QTY	QTY	QTY	ITEM	PART NUMBER	DESCRIPTION
		*	*	01-0271080-01	Model 7108001, 28V
	*	*	*	01-0271080-51	Model 7108051, 14V
*		*	*	01-0271080-06	Model 7108006, 28V
—	—	1	1	01-0271848-00	Assy, 28V LED Anti-Collision Light 71080
—	1	—	2	01-0271848-50	Assy, 14V LED Anti-Collision Light 71080
	1	1	3	07-771051-100	Plate, Adapter Model 8 Hole
4	4	4	4	16-0050506136	Washer, #6 Lock-Spring MS35338-136
4	4	4	5	14-0050503123	Screw, 6-32 X 9/16 PPHMS SS MS51957-123
1	1	1	6	38-0250885-00	Gasket, Lens Model 71055 Series
1	1	1	7	68-4971082A30	Lens, Clear LED Anti-Collision, Hard-coat
1	1	—	8	19-171047-100	Retainer, Lens, Iridite/Complete
4	4	4	9	16-0050506135	Washer, #4 Lock-Spring MS35338-135
4	4	4	10	14-0050505-14	Screw, 4-40 X 5/16 PPHMS MS51957-14
1	—	1	12	10-0315069-14	Label, Voltage ID +28V
—	1	—	13	46-0750898-01	Ass'y, 14V Pigtail 6" Blk/Red
1	—	—	14	01-0271848-01	Assy, 28V LED Anti-Collision Light 71080
1	—	—	15	07-771051-200	Plate, Adapter Model 4 Hole

## Models 7108004, 7108014 Exploded View Parts

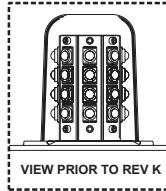
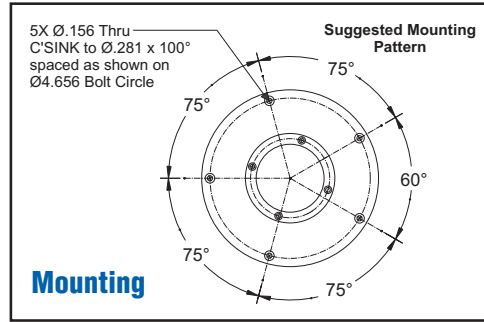
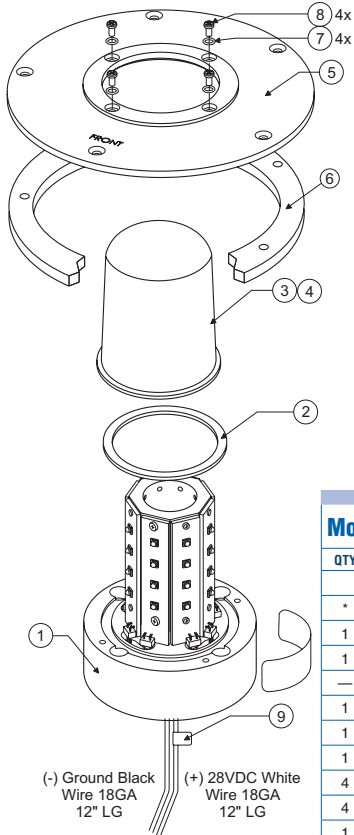

Model 7108004, 7108014 Series Parts List				
QTY	QTY	ITEM	PART NUMBER	DESCRIPTION
*	*		01-0771080-04	Model 7108004, 28V Upper
*	*		01-0771080-14	Model 7108014, 28V Lower
1	1	1	01-0271848-00	Assy, 28V LED Anti-Collision Light 71080
1	1	2	38-0250885-00	Gasket, Lens Model 71055 Series
—	1	3	68-4971082A30	Lens, Clear LED Anti-Collision, Hard-coat
1	—	4	68-4971082A31	Lens, Clear LED Anti-Collision, with Drain, Hard-coat
1	1	5	07-571304-100	5 Hole Adapter, Lens Retainer-Iridite
1	1	6	38-0250225-00	Seal, HR LT Series
4	4	7	16-0050506135	Washer, #4 Lock-Spring MS35338-135
4	4	8	14-0050505-14	Screw, 4-40 X 5/16 PPHMS MS51957-14
1	1	9	10-0315069-14	Label, Voltage ID +28V

## Dimensions

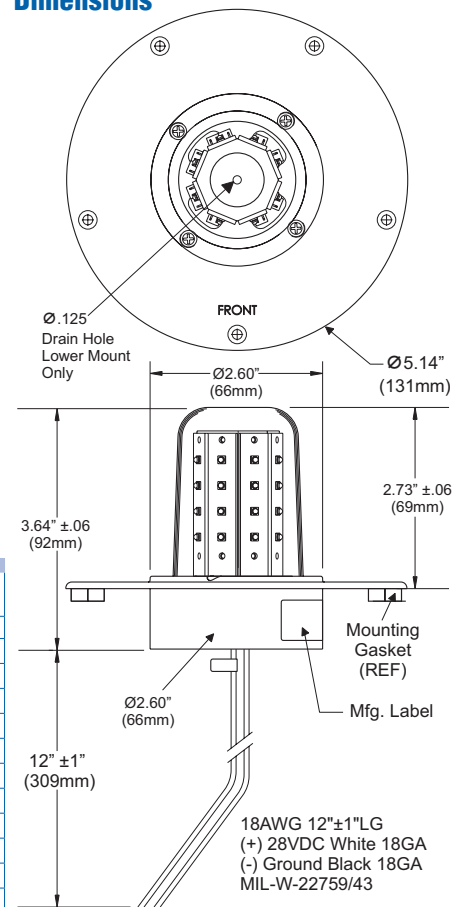

## Models 7108005, 7108015, 7108055 Exploded View Parts

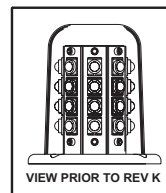
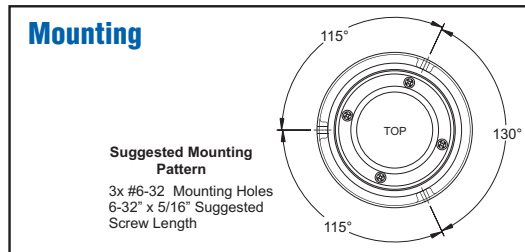
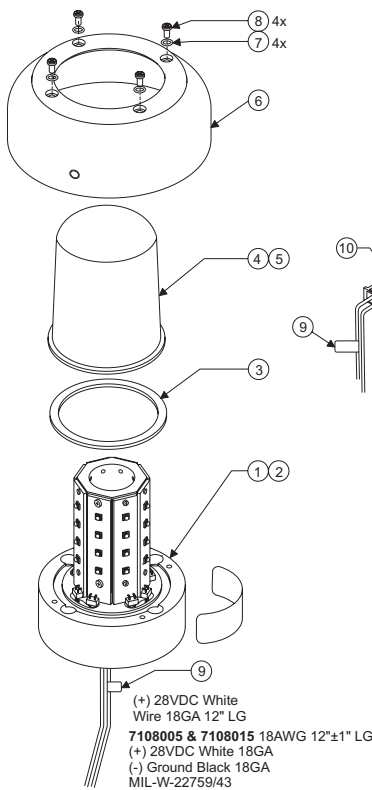

7108055 CONNECTOR WIRING AMP 1-480319-0			
POS. 1	(+) 14VDC	RED	
POS. 2	(-) GROUND	BLK	

Model 7108005, 7108015 and 7108055 Series Parts List					
QTY	QTY	QTY	ITEM	PART NUMBER	DESCRIPTION
*	*	*		01-0771080-05	Model 7108005, 28V Upper
*	*	*		01-0771080-15	Model 7108015, 28V Lower
*	*	*		01-0771080-55	Model 7108055, 14V
—	1	1	1	01-0271848-00	Assy, 28V LED Anti-Collision Light 71080
1	—	—	2	01-0271848-50	Assy, 14V LED Anti-Collision Light 71080
1	1	1	3	38-0250885-00	Gasket, Lens Model 71055 Series
1	—	1	4	68-4971082A30	Lens, Clear LED Anti-Collision, Hard-coat
—	1	—	5	68-4971082A31	Lens, Clear LED Anti-Collision, with Drain, Hardcoat
1	1	1	6	07-571361-100	3 3/4" Adapter, Mounting
4	4	4	7	16-0050506135	Washer, #4 Lock-Spring MS35338-135
4	4	4	8	14-0050505-14	Screw, 4-40 X 5/16 PPHMS MS51957-14
—	1	1	9	10-0315069-14	Label, Voltage ID +28V
1	—	—	10	46-0750898-01	Ass'y, 14V Pigtail 6" Blk/Red

## Dimensions

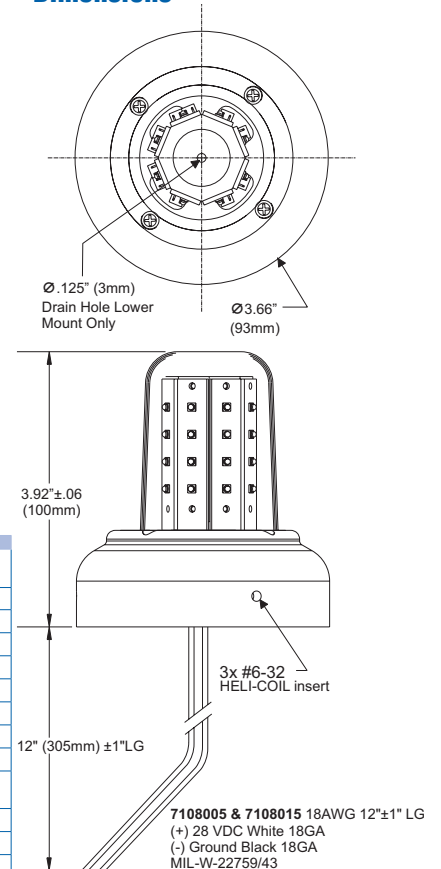

# Models 7108007, 7108017

## Exploded View Parts

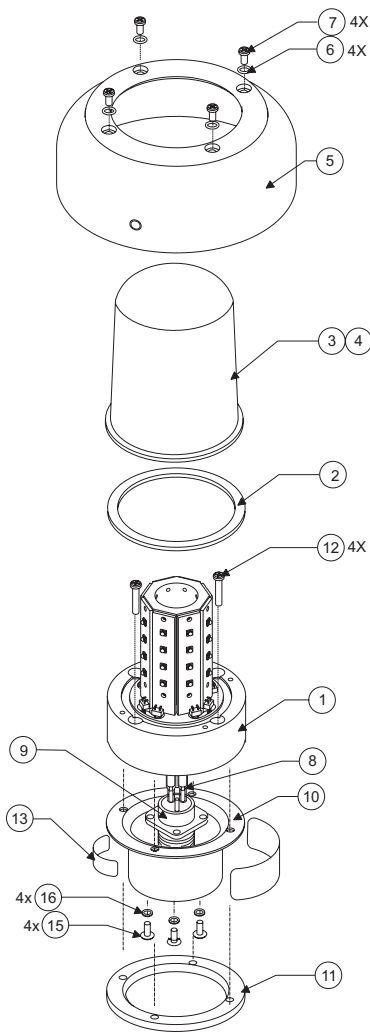

### Dimensions

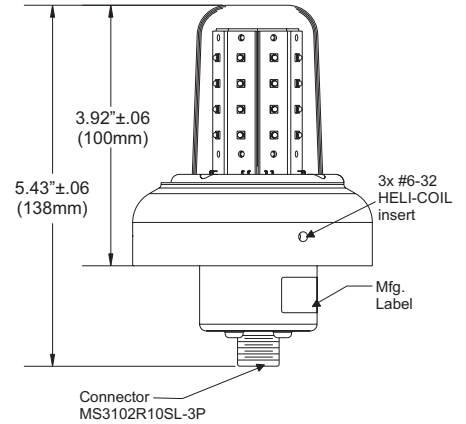
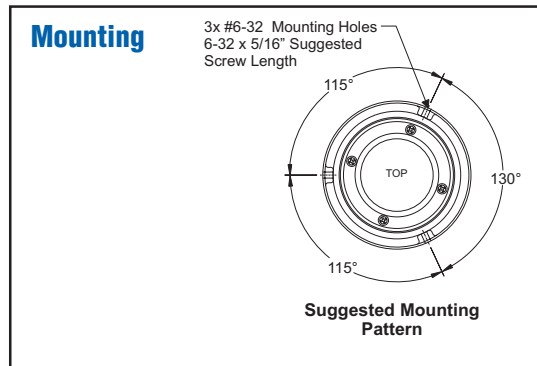
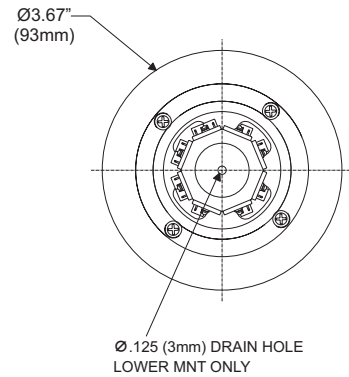

### Wiring

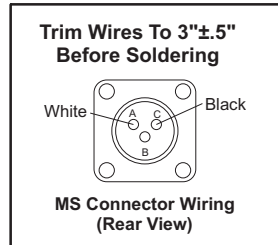

### Wiring

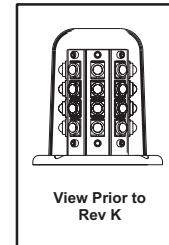
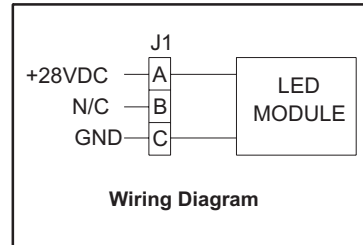

### Model 7108007, 7108017 Series Parts List

QTY	QTY	ITEM	PART NUMBER	DESCRIPTION
	*		01-0771080-07	Model 7108007 Upper, 28V
*			01-0771080-17	Model 7108017 Lower, 28V
1	1	1	01-0271848-00	Assy, 28V LED Anti-Collision Light 71080
1	1	2	38-0250885-00	Gasket, Lens Model 71055 Series
—	1	3	68-4971082A30	Lens, Clear LED Anti-Collision, Hard-coat
1	—	4	68-4971082A31	Lens, Clear LED Anti-Collision, with Drain, Hard-coat
1	1	5	07-571361-100	Adapter, Mounting 3-3/4"
4	4	6	16-0050506135	Washer, #4 Lock-Spring MS35338-135
4	4	7	14-0050505-14	Screw, 4-40 X 5/16 PPHMS MS51957-14
2	2	8	26-0715260-11	Shrink Tubing, 1/8" Dia X 1/2"
1	1	9	39-5903711-25	Conn, Pin, MS3102E10SL-3P Rework
1	1	10	11-450845-300	Housing, Connector Machined LED A/C Lt
1	1	11	07-750976-100	Plate, Nut Model 90520 w/Helicoils
4	4	12	14-0050503-34	Screw, 6-32 X 1 PPHMS MS51957-34
1	1	13	10-0331058-02	Label, Conn A/+28VDC C/GND
4	4	15	14-0050503-28	Screw, 6-32 X 3/8 PPHMS SS MS51957-28
4	4	16	16-0050506136	Washer, #6 Lock-Spring MS35338-136

# Models 7108008, 7108018

## Exploded View Parts

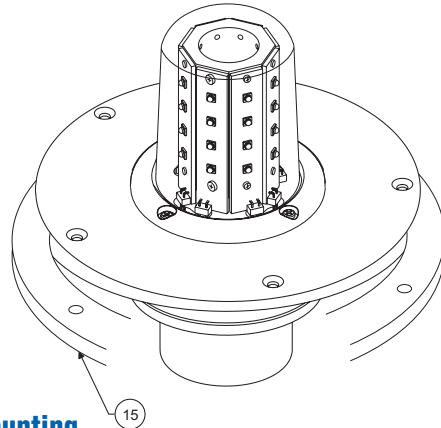
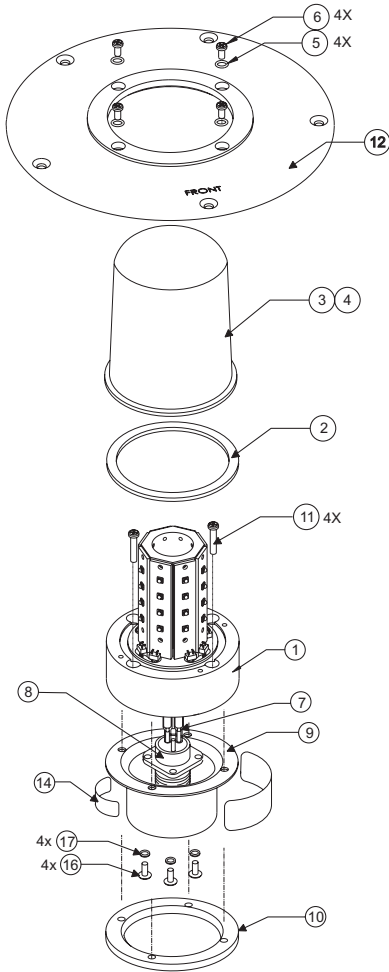

## Dimensions

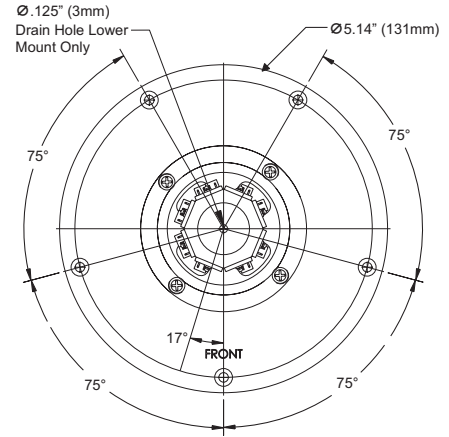

## Mounting

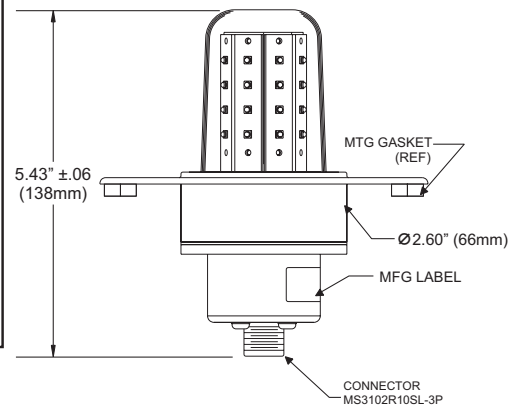
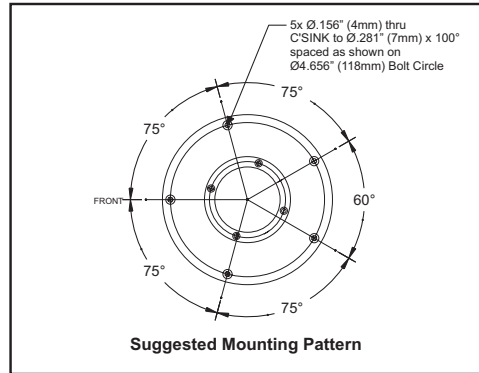

## Wiring

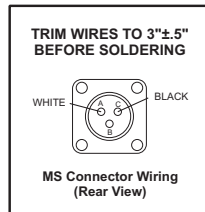

## Wiring Diagram

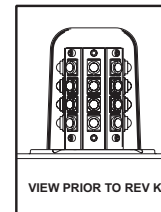
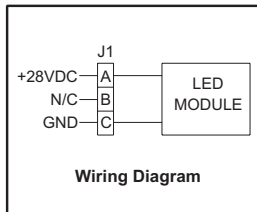

## Model 7108008, 7108018 Series Parts List

QTY	QTY	ITEM	PART NUMBER	DESCRIPTION
	*		01-0771080-08	Model 7108008 Upper, 28V
	*		01-0771080-18	Model 7108018 Lower, 28V
1	1	1	01-0271848-00	Assy, 28V Led Anti-Collision Light 71080
1	1	2	38-0250885-00	Gasket, Lens Model 71055 Series
—	1	3	68-4971082A30	Lens, Clear LED Anti-Collision, Hard-coat
1	—	4	68-4971082A31	Lens, Clear LED Anti-Collision, with Drain, Hard-coat
4	4	5	16-0050506135	Washer, #4 Lock-Spring MS35338-135
4	4	6	14-0050505-14	Screw, 4-40 x 5/16 PPHMS MS51957-14
4	4	7	26-0715260-11	Shrink Tubing, 1/8" Dia. x 1/2"
1	1	8	39-5903711-25	Conn, Pin, MS3102E10SL-3P Rework
1	1	9	11-450845-300	Housing, Connector Machined LED A/C LT
1	1	10	07-750976-100	Plate, Nut Model 90520, w/Helicoids
4	4	11	14-0050503-34	Screw, 6-32 X 1 PPHMS MS51957-34
1	1	12	07-571304-100	Adapter, 5-Hole Lens Retainer Iridite
1	1	14	10-0331058-02	Label, Conn A/+28VDC C/GND
1	1	15	38-0250225-00	Seal, HR LT Series
4	4	16	14-0050503-28	Screw, 6-32 X 3/8 PPHMS SS MS51957-28
4	4	17	16-0050506136	Washer, #6 Lock-Spring MS35338-136



# Models 7108020, 7108030

## Exploded View Parts

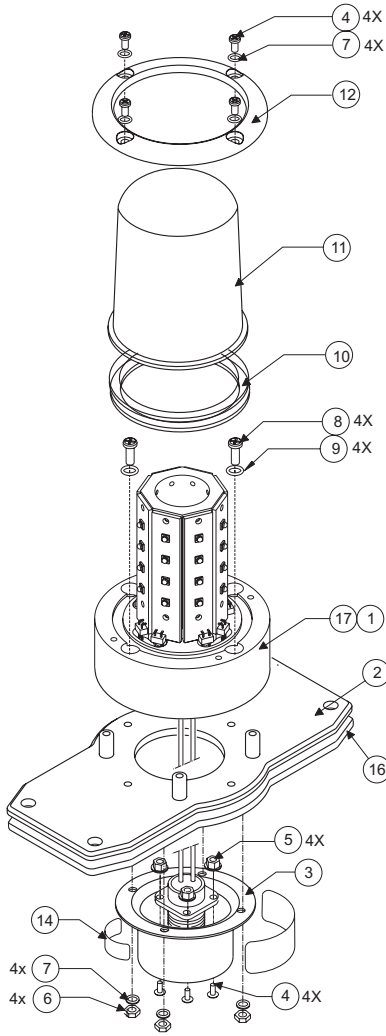

### Wiring Diagram

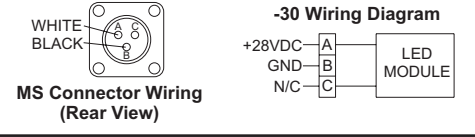

### Mounting

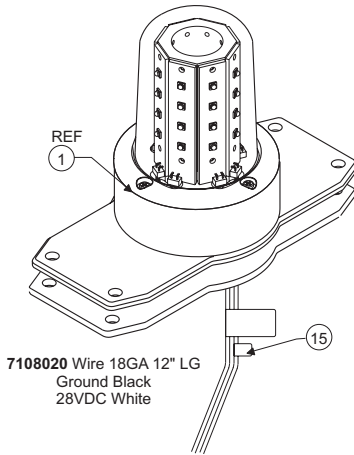
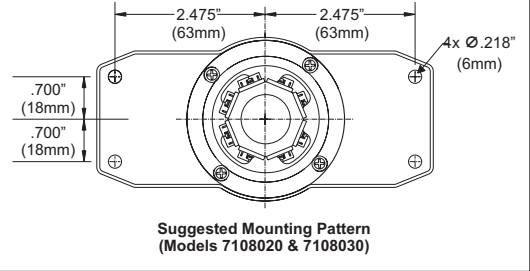

## Dimensions

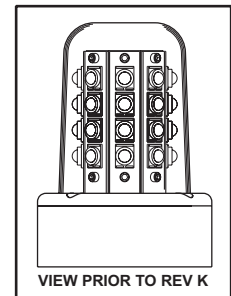
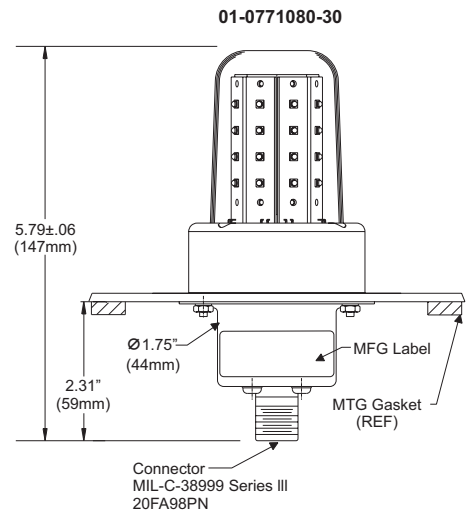
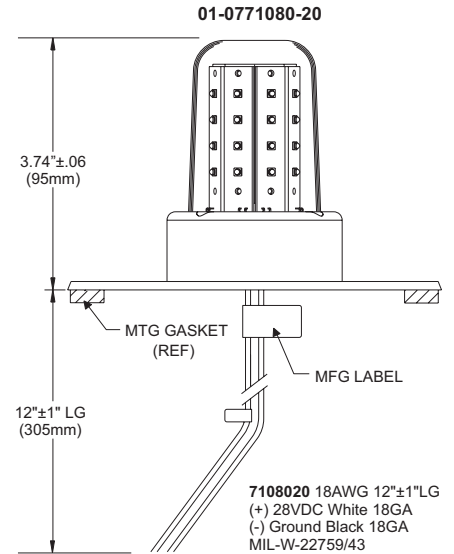
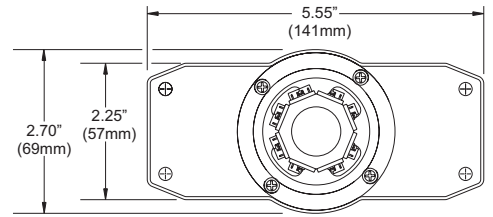

### Model 7108020, 7108030 Series Parts List

QTY	QTY	ITEM	PART NUMBER	DESCRIPTION
	*		01-0771080-20	Model 7108020 EC Style, 28V
	*		01-0771080-30	Model 7108030 EC Style, 28V
—	1	1	01-0271848-00	Assy, 28V LED Anti-Collision Light 71080
1	1	2	07-771393-110	Plate, Adapter EC Style Complete
1	—	3	11-450845-300	Housing, Connector Machined LED A/C LT
8	4	4	14-0050505-14	Screw, 4-40 x 5/16 PPHMS MS51957-14
4	—	5	13-0050517-04	Nut, 4-40 Self Lock Red Hex MS21042-04
4	—	6	13-0050513-44	Nut, 4-40 Plain Hex SS MS35649-244
8	4	7	16-0050506135	Washer, #4 Lock-Spring MS35338-135
4	4	8	14-0050503123	Screw, 6-32 x 9/16 PPHMS SS MS51957-123
4	4	9	16-0050506136	Washer, #6 Lock-Spring MS35338-136
1	1	10	38-0250885-00	Gasket, Lens Model 71055
1	1	11	68-4971082A30	Lens, Clear LED Anti-Collision, Hard-coat
1	1	12	19-171047-100	Retainer, Lens Iridite/Complete
1	—	14	10-0331058-01	Label, Conn A/+28VDC B/GRD
—	1	15	10-0315069-14	Label, Voltage ID +28V
1	1	16	38-0271394-00	Gasket, Adapter LED Beacon EC Style
1	—	17	01-0271848-03	Assy, 28V LED Anti-Collision Light 71080

# SELF CONTAINED LIGHT ASSEMBLIES

## MODEL 70900 ( ) SERIES FLASHING ANTI-COLLISION LIGHT ASSEMBLY

TSO-C96a CLASS III  
APPROVED



70900 series are FAA TSO compliant self-contained anti-collision lights for fixed wing aircraft. An external power unit is not required. Conservative lab life results greater than 20,000 hours. No EMI or RFI produced. All units meet the minimum requirements stated in FAR Parts 23 & 25 for anti-collision light systems used on fixed wing aircraft, Ref; Class III (100 effective candela) of SAE AS8017a minimum performance standards. STC SA615EA approved. **Models 7090004 & 7090005** are designed to replace existing light assemblies with the 3-3/4" (95mm) dia. mounting pattern (Ref. Whelen Aerospace HRCFA series, 90081 series, and "old style" rotating beacons). It has the same mounting hole pattern. No modification to the aircraft is required.

### Model 70900 ( ) Specifications

Model Numbers	Part Number	Mount	LENS / LED Color	Approvals	Input Current / Operational Voltage	Peak Input Current	Weight	Exposed Height / Diameter
7090004	01-0770900-04	3-3/4 dia. mount	Clear / Aviation Red	FAA TSO-C96a Class III	0.85 amps @ 14 VDC	4.5 Amps @ .25 Seconds	1.1 lbs. (499gm)	3.1" (78mm)
7090005	01-0770900-05				0.425 amps @ 28 VDC	2.25 Amps @ .25 Seconds		2.8" (71mm)

### Operation

**Equipment Limitations:** The Model 70900 series LED anti-collision light assembly meets the requirements of FAR 23.1401, 25.1401 and 91.205(c)(3). "If certification for night operations is requested, the airplane must have an anti-collision light system that consists of one or more approved anti-collision lights located so that their light will not impair the flight crew members vision or detract from the conspicuity of the position lights."

**Continued Airworthiness:** The 70900 series LED anti-collision light assembly is designed with 10 vertical columns consisting of 3 LEDs each. Should any one LED or any vertical column fail, the unit must be repaired or replaced.

**Installation Procedures:** The following information is to assist in the installation of a Whelen Aerospace LED Flashing Anti-Collision Light System.

1. The installation procedure described in the following text will be confined to a single light installation, but is identical for multiple light installations.
2. Prepare the aircraft for means to secure the LED Flashing Anti-Collision Light assembly (see reference AC 43.13-2A, Ch. 4).
3. 14 and 28 VDC (+) and (-) ground leads equipped with an appropriate sized breaker to be supplied to the LED Flashing Anti-Collision Light Assembly System. Both leads must be connected by an approved FAA connection. Insure that the wire leads and the pressure venting tube are all clear of any obstructions and ty-wrap as required. The pressure venting tube may be trimmed to minimum length of 1" from base.
4. Install the light assembly by securing to aircraft using #6-32 x 3/8" (maximum length) approved hardware. **Note:** Lens mounting screws installed at 5-7 in./lbs. of torque.
5. Check all avionics systems for interference from this installation.
6. A flight check should be performed by a properly certified pilot.
7. All inverted (bottom) mounted units shall require waterproofing of the unused mounting holes. An application of single-part silicone (RTV) or equivalent applied into mounting holes is recommended (see illustration on page 11, Fig.11A). Inverted and/or standard mounted units, when necessary, may require waterproofing around any open area where water could get in. Specifically, the lens to the flasher base assembly, and the flasher base assembly to the aircraft.
8. Update aircraft records, complete Form 337 and obtain FAA field approval for installation. **If not covered under STC eligibility list.**

### Dimensions

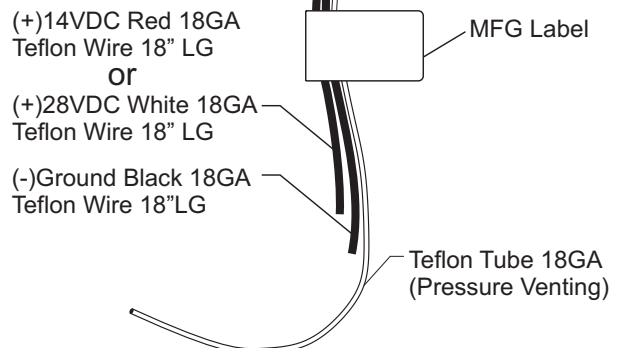
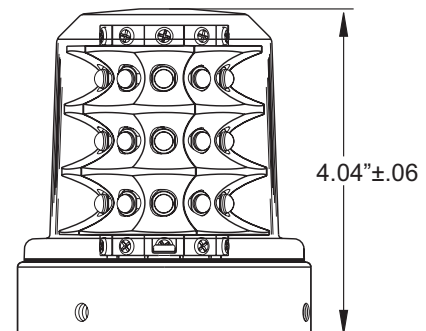
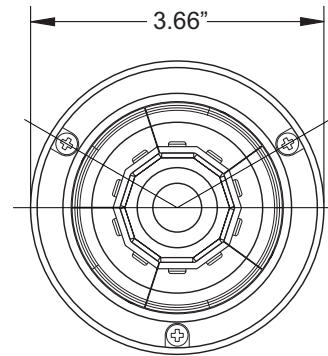

# Models 7090004, 7090005

## Exploded View Parts

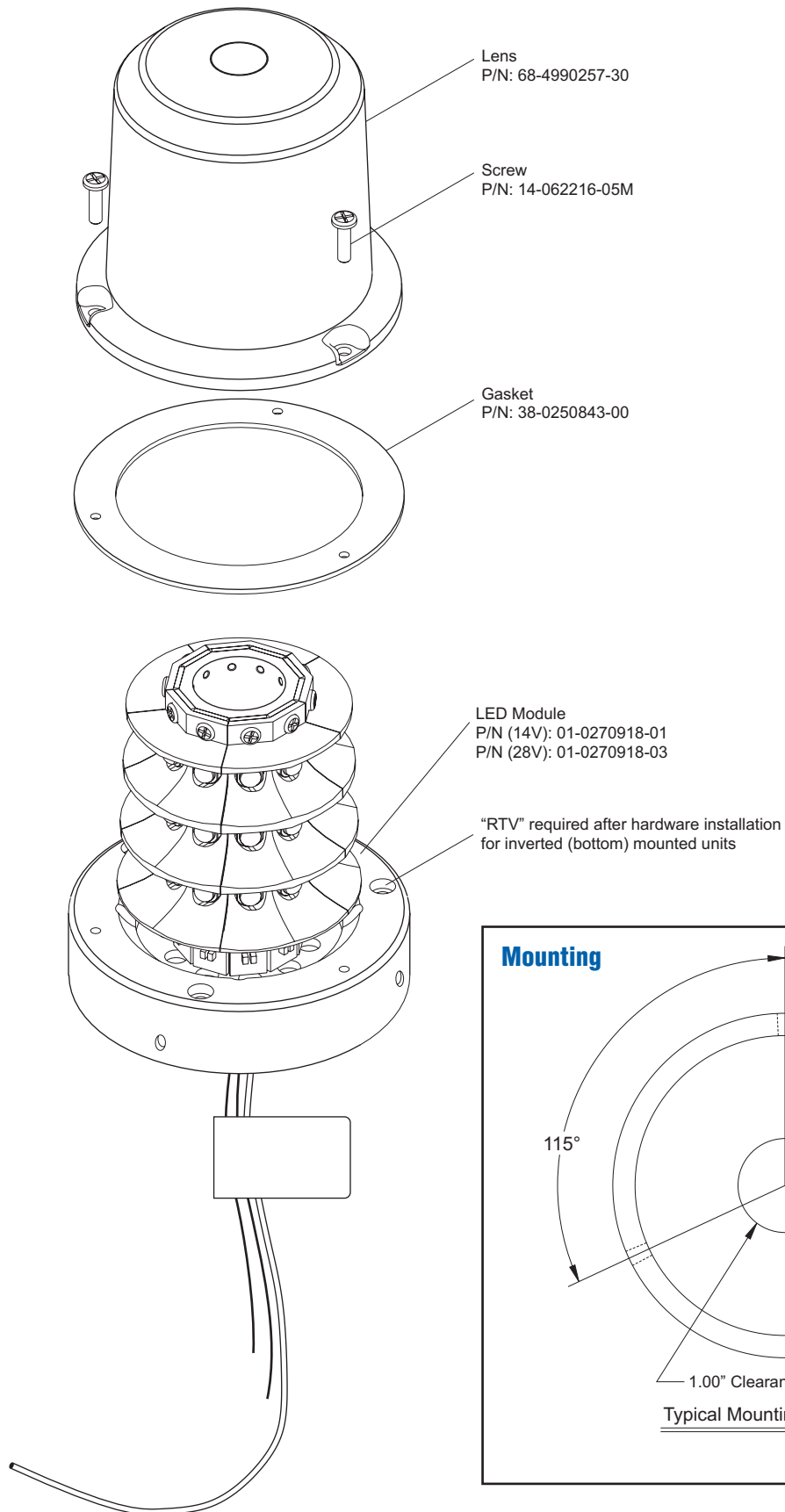

Before LED installation



Model 70900 series after LED installation



Model 70900 series after LED installation

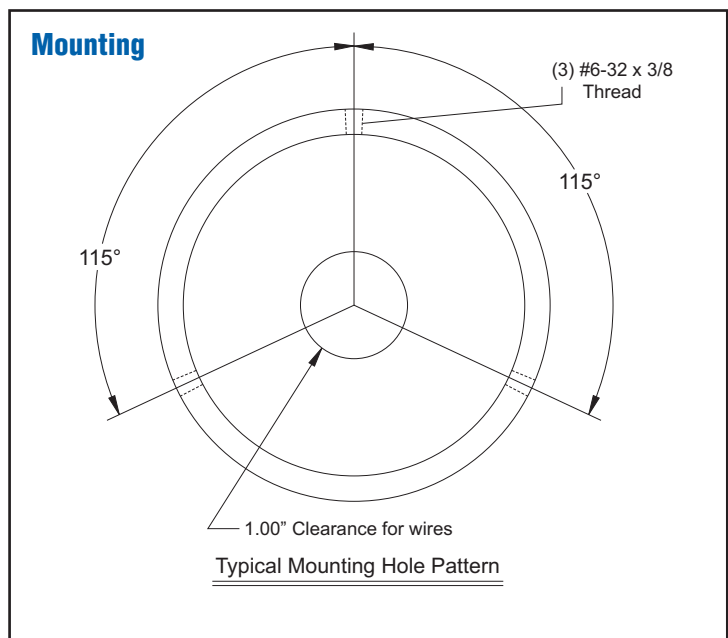

# SELF CONTAINED LIGHT ASSEMBLIES

## MODEL 71055 ( ) SERIES LED BEACON ANTI-COLLISION LIGHT ASSEMBLY

71055 series beacons are FAA TSO compliant self-contained LED Anti-Collision lights. They are designed to replace existing quartz halogen flasher beacons installed as original equipment on single engine Cessna's from 1967 and later (contact factory for details). They can also replace remote mounted strobe lights (ref. Whelen Aerospace A470 series) allowing for removal of the strobe power supply. Internal mounting plate provided with choice of mounting holes to retrofit most existing mounting patterns. STC SA615EA approved.

**TSO-C96a CLASS III APPROVED**



### Model 71055 ( ) Specifications

Model Numbers	Part Number	Voltage	LED Color	Operational Voltage	Input Current	Peak Input Current	Flash Rate	Weight	Approvals	Lenses
7105500	01-0771055-00	14 VDC	Aviation Red	9-14 VDC	0.75 Amp Avg (ACL)	4.0 Amps Pulse	45 ± 5 FPM	0.55 lbs (249gm) REF	FAA TSO-C96a Class III	Clear Polycarbonate
7105501	01-0771055-01	28 VDC		22-32 VDC	0.56 Amp Avg (ACL)	1.5 Amps @ 0.25 Seconds		0.48 lbs (218gm) REF		

### Operation

**Equipment Limitations:** The Model 71055 Series LED anti-collision light assembly meets or exceeds the requirements of FAR 23.1401, and FAR 91.205(c)(3).

**Continued Airworthiness:** The 71055 Series LED anti-collision light assembly is designed with 6 vertical columns consisting of 2 or 3 LED's each. Should any one LED or any vertical column fail, the unit must be repaired or replaced. Periodically inspect the lens and replace if there is excessive scratching, discoloration or cracking.

**Installation Procedures:** The Model 71055 is a self contained flashing beacon that requires no external flasher or power supply. In some installations, it may be necessary to remove several existing components. When replacing flashing halogen beacon assemblies, the flasher box and ballast resistor (if present), and associated wiring, need to be removed. When replacing strobe light assemblies, the strobe power supply must be removed. In both cases, 18 gage DC voltage wires, A+ & Ground (-), must be continued from the location of the previous box, (flasher or power supply), to the location of the new LED beacon.

The following information is to assist in the installation of a Whelen Aerospace LED Flashing Anti-Collision Light System.

1. The installation procedure described in the following text will be confined to a single light installation, but is identical for multiple light installations.
2. Using the "suggested mounting hole pattern" prepare the aircraft for means to secure the LED Flashing Anti-Collision Light assembly. Remove any existing mounting adapters.
3. 14 / 28 VDC (+) and (-) ground leads equipped with an appropriate sized breaker to be supplied to the LED Flashing Anti-Collision Light Assembly System. Both leads must be connected by an approved FAA connection. Insure that the wire leads and the pressure venting tube are all clear of any obstructions and ty-wrap as required.
4. Install the light assembly by first removing the lens. Remove the adapter plate. Attach the adapter plate to the aircraft mounting holes. Refer to page 2. Reinstall the light assembly and lens.
5. Check all avionics systems for interference from this installation.
6. A flight check should be performed by a properly certified pilot.
7. All inverted (bottom) mounted units shall require waterproofing of the flasher base assembly to the aircraft. Note: Drill a 1/8" hole in the center of the lens for bottom mount units.
8. Update aircraft records, complete Form 337 and obtain FAA field approval for installation. **If not covered under STC eligibility list.**

**TSO-C96a Class III approved:** The conditions and tests required for TSO approval of this article are minimum performance standards. It is the responsibility of those installing this article either on or within a specific type or class of aircraft to determine that the aircraft installation conditions are within the TSO standards. TSO articles must have separate approval for installation in aircraft. The article may be installed only if performed under 14 CFR part 43 or the applicable airworthiness requirements.

### Dimensions

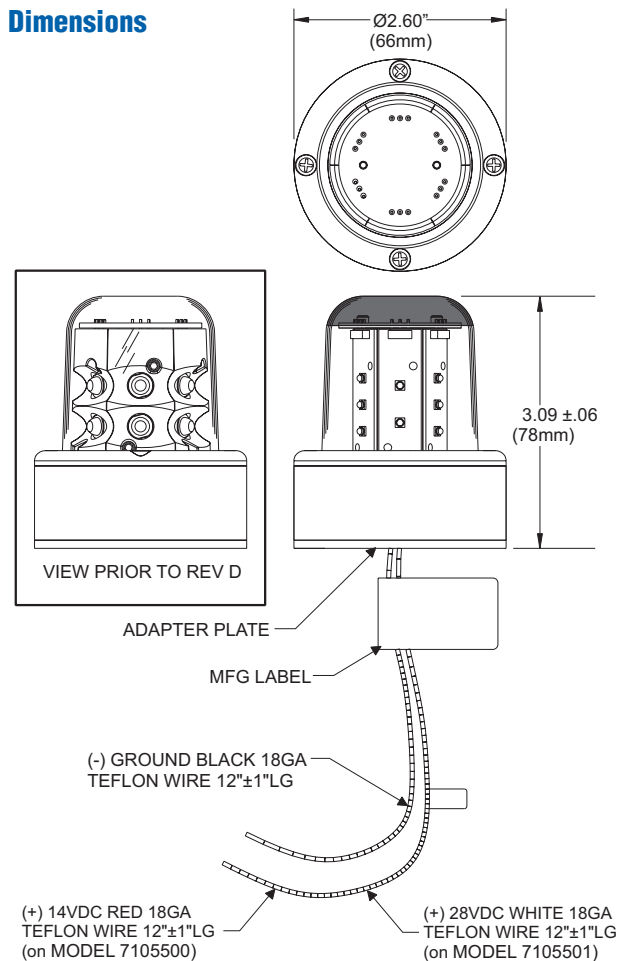

## Models 7105500, 7105501 Exploded View Parts

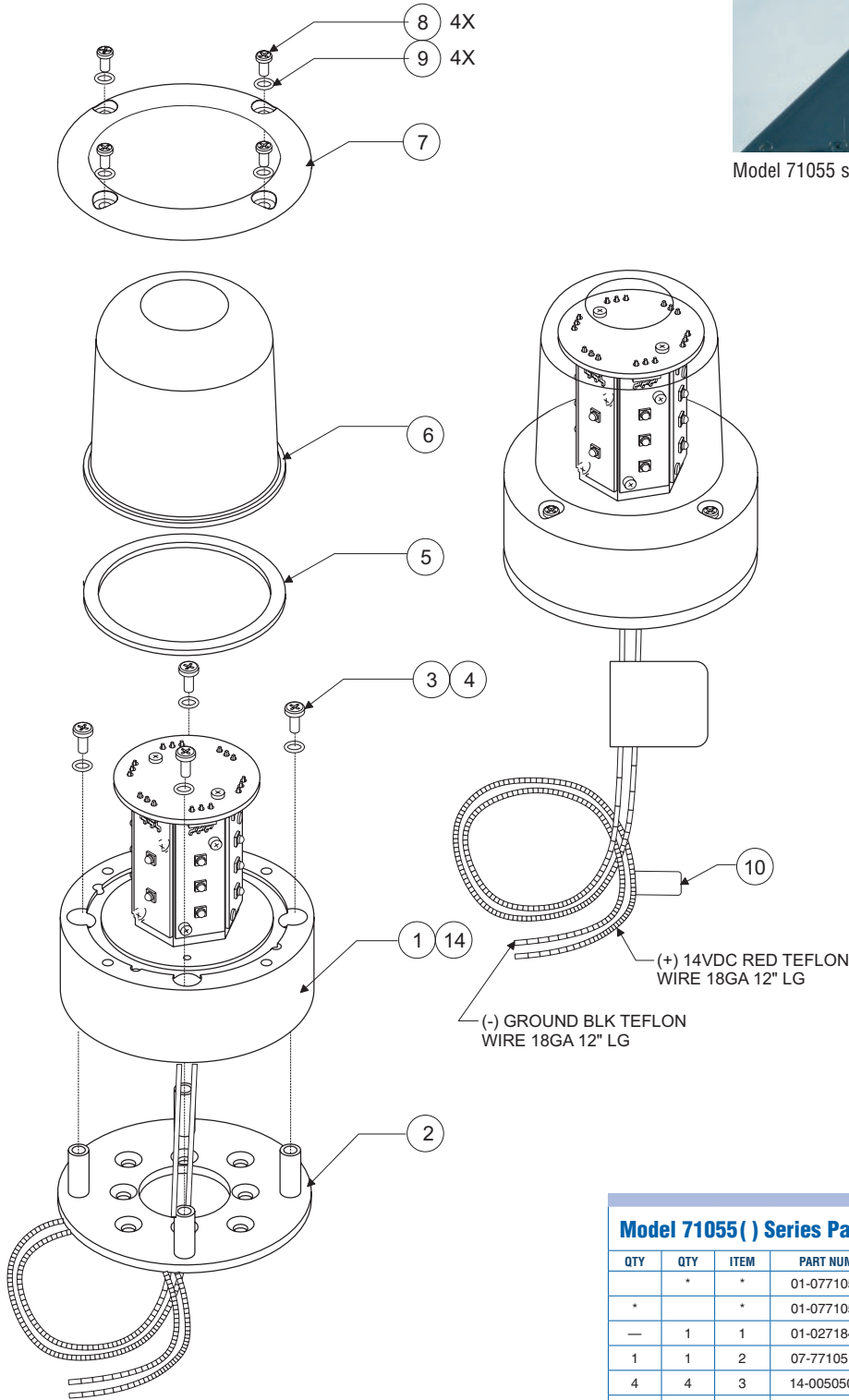

Model 71055 series LED installation

### Mounting

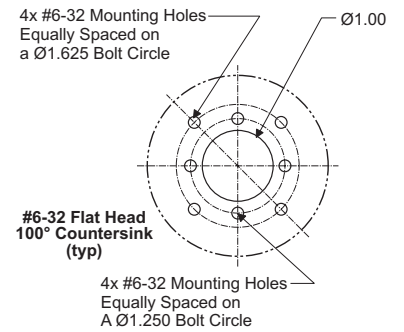

### Suggested Mounting Hole Pattern

### Model 71055 ( ) Series Parts List

QTY	QTY	ITEM	PART NUMBER	DESCRIPTION
	*	*	01-0771055-00	MODEL 7105500, 14V
	*	*	01-0771055-01	MODEL 7105501, 28V
—	1	1	01-0271843-00	LED MODULE ASSEMBLY 6 SIDED (14V)
1	1	2	07-771051-100	ADAPTER PLATE MODEL 71055 SERIES
4	4	3	14-0050503123	SCREW, 6-32 X 9/16 PPHMS MS51957-123
4	4	4	16-0050506136	WASHER, #6 LOCK-SPRING MS35338-136
1	1	5	38-0250885-00	GASKET, LENS MODEL 71055 SERIES
1	1	6	68-4971046-30	LENS, CLEAR MODEL 71055 SERIES
1	1	7	19-171047-100	RETAINER, LENS MODEL 71055 SERIES
4	4	8	14-0050505-14	SCREW, 4-40 X 5/16 PPHMS MS51957-14
4	4	9	16-0050506135	WASHER, #4 LOCK-SPRING MS35338-135
1	1	10	10-0315069-13	LABEL, VOLTAGE ID +14V
1	—	14	01-0271829-01	ASSY, 28V LED ANTI-COLL LT



## MODEL HRCFA SERIES SELF-CONTAINED STROBE ANTI-COLLISION LIGHT ASSEMBLY

HRCFA series is a self-contained CometFlash® strobe Anti-Collision light. The unique polycarbonate optic lens and reflector design re-directs stray light rays into the horizontal plane to provide maximum 360° of uniform light coverage. Available in three different lens colors, aviation Red, aviation White and split aviation Red/White and in radio-shielded configurations. FAA approved as a direct replacement for any rotating beacon that uses a 3-3/4" (95mm) dia. mounting hole. Can be installed in the vertical fin or the fuselage. **Fuselage installation requires the A440 mounting adapter.** Operates between 10 to 30 VDC.



### Model HRCFA Specifications

Model Numbers	Part Number	Description	Mount	Polycarbonate Optic Lens	Approvals	Input Current / Operational Voltage	Weight
HRCFAR	01-0770029-29	Standard Assembly	3-3/4" (95mm) diameter mounting hole in the vertical fin or the fuselage	Red	FAA/PMA	3.2 amps @ 14 VDC 1.6 amps @ 28 VDC	1.5 lbs. (680gm)
HRCFAW	01-0770029-30			White			
HRCFAS	01-0770029-31			Split Red/White			
HRCFADR	01-0770029-32	Radio Shielded		Red			
HRCFADW	01-0770029-33			White			
HRCFADS	01-0770029-34			Split Red/White			
HRCFADRM	01-0770029-36	RFI Shielded with MS Connector		Red			
HRCFADWM	01-0770029-37			White			
HRCFADSM	01-0770029-38			Split Red/White			

## MODEL SACF SELF-CONTAINED STROBE ANTI-COLLISION LIGHT ASSEMBLY

SACF series self-contained CometFlash strobe anti-collision light which utilizes the same power supply & housing as the model HRCFA. It uses an aviation White glass lens only, ideal for agricultural applications where chemicals are used. Because the lens has no optics built-in, it produces 300 effective candlepower. It uses a 3-3/4" dia. mounting hole. **Fuselage installation requires the A440 mounting adapter.** Operates between 10 to 30 VDC.



### Model SACF Specifications

Model Numbers	Part Number	Mount	Lens	Approvals	Input Current / Operational Voltage	Weight	Height / Diameter
SACF	01-0770030-01	3-3/4" dia. mounting hole, fuselage installation requires the A440 mounting adapter	Glass Lens, No Optics Aviation White	FAA/PMA	3.2 Amps @ 14 VDC & 1.6 Amps @ 28 VDC	1.5 lbs. (680gm)	5.50" (140mm) / 3.7" (94mm)

## A440 MOUNTING ADAPTER

The model A440 Mounting Adapter, is for fuselage installations for the HRCFA series, and the SACF series.

### Model A440 Specifications

Model Numbers	Part Number	Mount	Approvals	Weight	Outside Diameter
A440	19-130074-009	Mounting Adapter for HRCFA & SACF Series for fuselage installations	—	—	5" (127mm)



## Installation

The HRCFA & SACF self-contained strobe light assemblies are interchangeable with Rotating Beacons on any aircraft with a 3.75 inch diameter fairing or mounting adapter. It is not necessary to change any of the existing wiring, or circuit breakers. The light assembly must be properly mounted to comply with FAR Part 91.205(c-2) & (c-3). When necessary (such as fuselage installation), the Whelen Aerospace model A440 mounting adapter must be used.

## Mounting

1. Remove the existing beacon.
2. Make the necessary wiring connections using the existing wiring. Positive (+) to the WHITE wire, and Ground (-) to the BLACK wires protruding from the light assembly. All connections must use FAA approved techniques.

**Note:** It is recommended to ground the unit to the buss bar or the battery. Using the airframe as ground may produce EMI/RFI interference.

3. Remove the three (3) 6-32 x 3/8" mounting screws from the light assembly. Do not use longer screws, damage to the unit may occur.
4. Insert light assembly into mounting location and attach using screws as mentioned in step 3. There are two sets of mounting screw locations on the unit for installation versatility (unit may be sealed around periphery with RTV or equivalent).
5. If the A440 mounting adapter is used, attach light assembly to adapter

using screws as mentioned in step 3 (unit may be sealed around periphery with RTV or equivalent).

6. If light assembly is mounted in an inverted position, drill a 1/8" diameter hole in lens as indicated on the lens label. For the model SACF series, remove the RTV plug from the hole in the lens.
7. When installing the light assembly in a rudder mount location, rudder balance must be checked with reference to the aircraft's service manual. The weight and balance should equal the original rotating beacon.
8. Check all avionics systems for interference from the installation with reference to AC 43.13-2a, Chapter 4, paragraph 52 (b).
9. Label all switches and breakers, install pilot warning placard.
10. Update aircraft records, complete Form 337 and obtain FAA field approval for installation, **if not covered under STC eligibility list.**

## Flash Tube Replacement

1. When a flash tube failure occurs, remove the #6 Phillips head screw on the clamp ring. Be careful not to lose the #6 hex nut.
2. Remove the clamp ring.
3. Lift the lens assembly & gasket off the strobe tube.
4. Lift the strobe tube and carefully unplug the connector.
5. Replace with new strobe tube assembly.
6. Attach all parts required. See parts breakdown for replacement part numbers.

## Dimensions

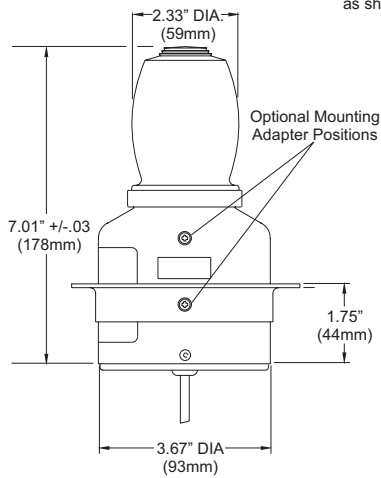

## Exploded View

\*Note\*  
Align Reflectors  
as shown

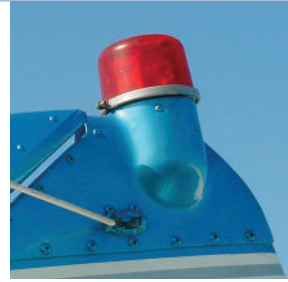
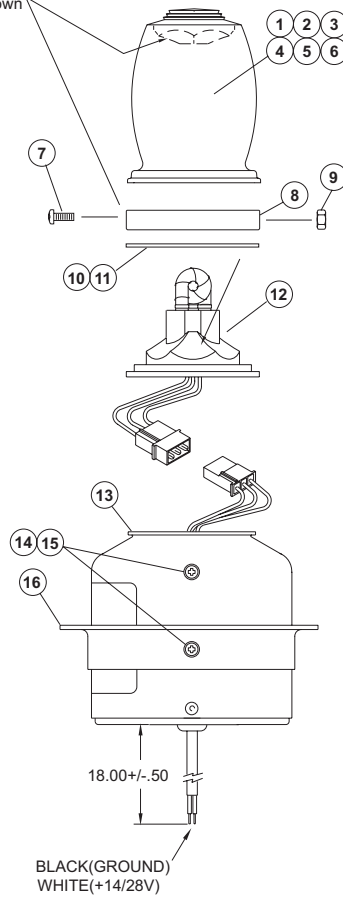

Before with Rotating Beacon



After with Strobe Light

## Model HRCFA Parts List

ITEM	PART NUMBER	DESCRIPTION
1	68-2170504-50	LENS, A402AR
2	68-2170504-30	LENS, A402AW
3	68-2170504-60	LENS, A402AS
4	68-2170504R50	LENS, A402ADR
5	68-2170504R30	LENS, A402ADW
6	68-2170504R60	LENS, A402ADS
7	N/A	#6-32x1/2 PPHMS(MS51957-30)
8	01-0450685-00	CLAMP RING
9	N/A	#6-32 X 5/16 SS HEX NUT (MS35649-264)
10	38-0230840-00	GASKET
11	38-0250429-00	RFI GASKET
12	01-0770044-02	A469B FLASH TUBE ASSY.
13	01-0770619-00	POWER SUPPLY ASSEMBLY
14	N/A	#6-32x3/8 PPHMS(MS51957-28)
15	N/A	#6 INT. TOOTH LW(MS35333-71)
16	19-130074-100	A440 MOUNTING FLANGE (OPTIONAL)

## Mounting

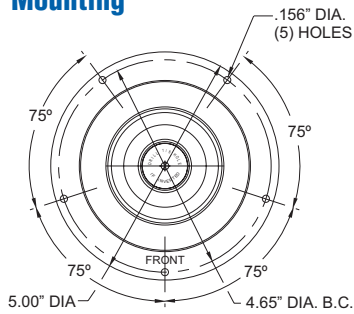

## Dimensions

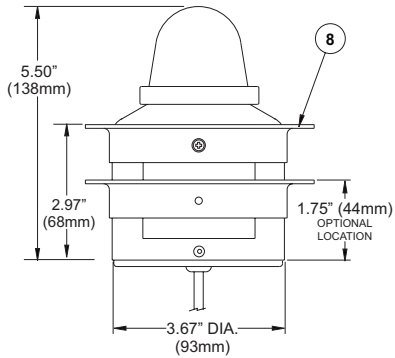

## Exploded View

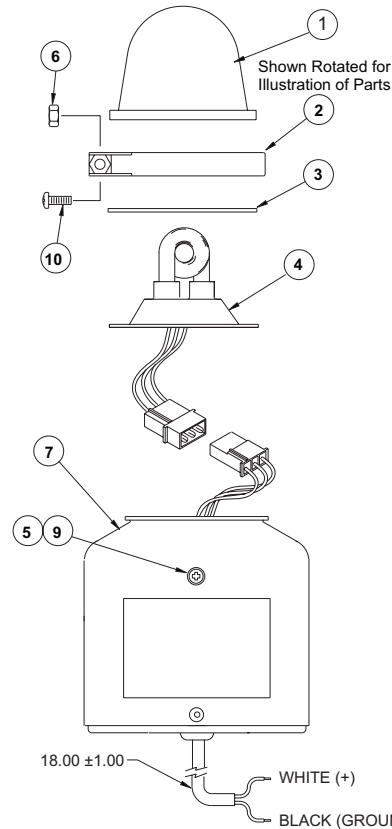

## Model SACF Parts List

ITEM	PART NUMBER	DESCRIPTION
1	68-4230044-30	SA402 LENS (CLEAR)
2	01-0450685-00	CLAMP RING
3	38-0230946-00	GASKET
4	02-0350053-00	SA406 FLASH TUBE ASSEMBLY
5	N/A	#6-32 x 3/8 PPHMS (MS51957-28)
6	N/A	#6-32 x 5/16 SS HEX NUT (MS35649-264)
7	01-0770619-00	POWER SUPPLY HR-CF 14/28V
8	19-130074-100	A440 MOUNTING FLANGE (OPTIONAL)
9	N/A	#6 INT TOOTH L/W (MS 35333-71)
10	N/A	#6-32 x 1/2 PPHMS (MS51957-30)

## Mounting

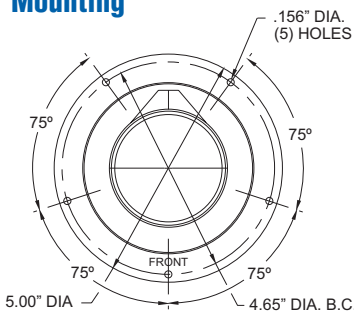

# STROBE LIGHTHEAD ASSEMBLIES

## MODEL A470A SERIES

A470A series remote strobe light assembly is compatible with all Whelen Aerospace power supplies. It can be installed on the fuselage or the vertical fin. The unique polycarbonate optic lens and reflector design, re-directs stray light rays into the horizontal plane to provide the maximum 360° of uniform light coverage possible. Available in three different lens colors, Aviation Red, Aviation White and split Aviation Red/White. Available in radio-shielded configurations. All assemblies require either the model H102 or H103 mounting adapter.



### Model A470A Specifications

Model Numbers	Part Number	Description	Polycarbonate Optic Lens	Approvals	Input Current / Operational Voltage	Weight	Exposed Height / Diameter
A470AR	01-0770019-18	Standard Assembly	Red	FAA/PMA	Dependant on strobe power supply used	0.3 lbs. (136gm)	3.75" (95mm) 2.5" (64mm)
A470AW	01-0770019-19		White				
A470AS	01-0770019-20		Split Red/White				
A470ADR	01-0770019-21	Radio Shielded	Red				
A470ADW	01-0770019-22		White				
A470ADS	01-0770019-23		Split Red/White				

## MODEL A450 REMOTE STROBE - FUSELAGE/VERTICAL

A450 series remote strobe light assembly is compatible with all Whelen Aerospace power supplies. It can be installed on the fuselage or the vertical fin. The Pyrex® Glass lens (Clear only) makes the assembly suitable for use in severe vibration, chemical and moisture conditions (i.e. agricultural aircraft). Requires either the model H102 or model H103 mounting adapter.



### Model A450 Specifications

Model Numbers	Part Number	Mount	Lens	Approvals	Input Current / Operational Voltage	Weight	Exposed Height / Diameter
A450	01-0770032-00	Standard assembly, installed on the fuselage or the vertical fin	Clear Pyrex® Glass lens, No Optics Aviation White	FAA/PMA	Dependant on strobe power supply used	0.3 lbs. (136gm)	2.25" (57mm) / 2.5" (64mm)

## MODELS H102 & H103 MOUNTING ADAPTERS

Designed for the Model A470A or Model A450 series remote strobe lighthead assemblies. The Model H102 allows flush mounting of the lighthead to the skin of the fuselage or the vertical stabilizer on later model Cessna Single engines. The H103 is designed for strobe assemblies to be installed in the standard 3-3/4" (95mm) dia. rotating beacon mounting hole.



### Model A440 Specifications

Model Numbers	Part Number	Mount	Approvals
H102	07-730068-000	Flush mount adapter	FAA/PMA
H103	11-230079-000	For standard 3-3/4" (95mm) dia. rotating beacon mounting hole	—

## Quartz Type Flasher Replacements



Before with Quartz Light



After with Remote Strobe Light



Model A470A Installation

The A450 and A470A remote anti-collision strobe lighthead assemblies are direct replacement for the quartz-type flasher, using the original or the H102 "B" mounting adapter. The H102 "B" mounting adapter is mounted in the aircraft's structure, with four (4) MS 20470 AD4 rivets, or four (4) 6-32 screws and self-locking nuts. Drill out the center hole in the skin to allow access to the strobe head connector.

### H102 Mounting Adapter

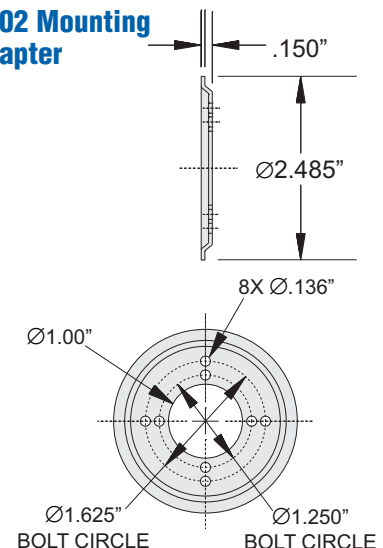

## Vertical Fin and Rudder Mounting of Anti-Collision Strobe Lights

Rudder mounted anti-collision lights should be located top center of the rudder hinge center line, or rudder balance must be established after installation. Refer to AC 43.13-2A, Chapter 4, Paragraph 55(e), "Rudder Installation". The rudder or fin cap is excellent for shadowing the prop and cabin area if the light is mounted far enough back.

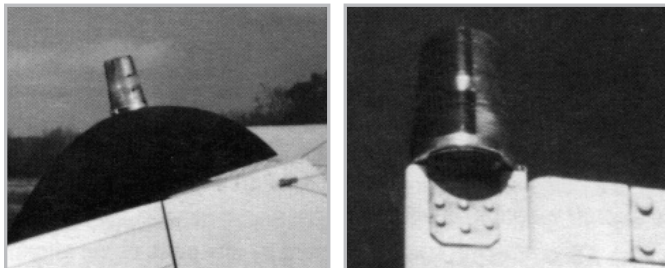

**NOTE:** Mounting an A450 or A470A strobe lighthouse assembly on a vertical fin or rudder, can be accomplished by fabricating a mounting adapter similar to the ones shown in illustrations.

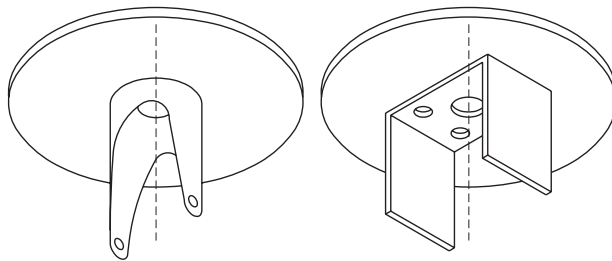

Round or streamline tubing cut to fit rudder or vertical fin welded to 2 1/2" OD .40" thick disc. (Reference AC 43.13-1B, Chapter 2, Section 2).

Metal bracket shaped to fit the vertical fin or rudder with 2 1/2" OD .40" thick disc riveted in place. (Reference AC 43.13-1B, Chapter 2).

Fabrication and installation of these mounting brackets are referenced in this approved installation manual, and AC 43.13-1B and 2A.

Documentation of structural integrity of the fabricated installation must be approved by an "IA" or other representative of the FAA. Conformity inspections will be performed with reference to approved techniques, and procedures specified in this manual (see page 3).

## A470A Dimensions

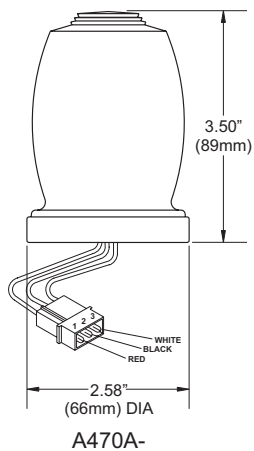

QTY	QTY	QTY	QTY	QTY	QTY	ITEM	PART NUMBER	DESCRIPTION
					*	*	01-0770019-18	Strobe Assy. - Red (A470A-R)
				*	*		01-0770019-19	Strobe Assy. - White (A470A-W)
			*				01-0770019-20	Strobe Assy. - Red/White (A470A-R/W)
		*					01-0770019-21	Strobe Assy, R S - Red (A470A-D-R)
	*						01-0770019-22	Strobe Assy, R S - WHITE (A470A-D-W)
							01-0770019-23	Strobe Assy, R S - R/W (A470A-D-R/W)
—	—	—	—	—	1	1	68-2170504-50	Lens Assy, (Red)
—	—	—	—	1	—	2	68-2170504-30	Lens Assy, (White)
—	—	—	1	—	—	3	68-2170504-60	Lens Assy, (Red/White)
—	—	1	—	—	—	4	68-2170504R50	Lens Assy, R S - (Red)
—	1	—	—	—	—	5	68-2170504R30	Lens Assy, R S - (White)
1	—	—	—	—	—	6	68-2170504R60	Lens Assy, R S - (Red/White)
1	1	1	1	1	1	8	01-0450685-00	Clamp Ring Ø.50
1	1	1	—	—	—	9	38-0250429-00	Gasket, Shielded
1	1	1	1	1	1	10	01-0770044-02	Flashtube Assy (A469B)
—	1	1	1	1	1	11	N/A	#6-32 x 1/2 Phillips PHMS(MS51957-30)
—	—	—	1	1	1	12	38-0230840-00	Gasket
1	1	1	1	1	1	15	N/A	#6-32 x 5/16 SS Hex Nut (MS35649-264)
—	—	—	—	—	—	17	02-0350600-01	Lens Assy, Masked (White)

## Exploded View

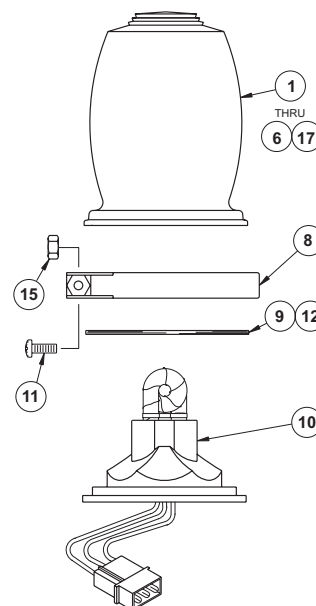

## SACF Dimensions

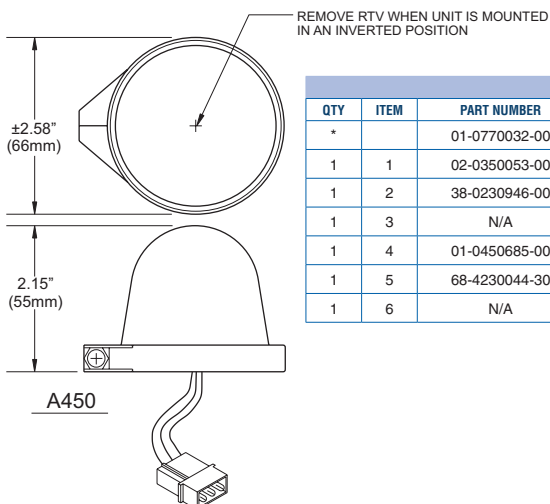

QTY	ITEM	PART NUMBER	DESCRIPTION
*		01-0770032-00	A450 STROBE LIGHT HEAD ASSEMBLY
1	1	02-0350053-00	FLASH TUBE ASSY.
1	2	38-0230946-00	GASKET, LENS .046" THK
1	3	N/A	#6-32 X 1/2 PHILLIPS PHMS(MS51957-30)
1	4	01-0450685-00	CLAMP RING Ø.50
1	5	68-4230044-30	LENS (Clear)
1	6	N/A	#6-32 X 5/16 SS HEX NUT (MS35649-264)

## Exploded View

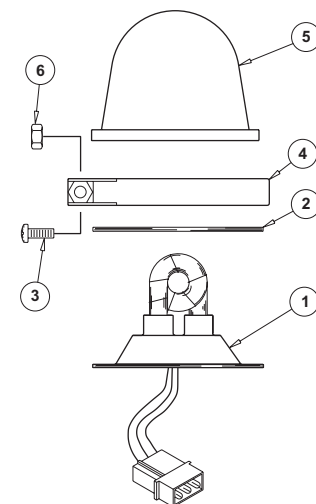



## MODEL A650PG/PR SERIES WINGTIP STROBE ANTI-COLLISION/POSITION LIGHT ASSEMBLY

A650 PG/PR Series wingtip with Anti-Collision & Forward Position lights can be used to convert non-Whelen Aerospace Position lights into a Position/Anti-Collision light system. The small size allows for mounting into a wing tip enclosure. Available in 14 or 28 VDC and in a radio shielded version. The forward position lamp is 26 watts.



### Model A650PG/PR Specifications

Model Numbers	Part Number	Mount	Lens Color	Approvals	Nav Light Input Current / Operational Voltage	Peak Input Current	Weight	Length / Width / Height
A650PG1	01-0770054-00	Standard Assembly	Position Green	FAA/PMA	2.0 Amps @ 14 VDC	Dependant on strobe power supply used	0.6 lbs.	3.84" L x 1.7" W x 2.4" H
A650PG2	01-0770054-01		Position Green		1.0 Amps @ 28 VDC			
A650PR1	01-0770054-02		Position Red		2.0 Amps @ 14 VDC			
A650PR2	01-0770054-03		Position Red		1.0 Amps @ 28 VDC			
A650PGD1	01-0770054-04	Radio Shielded	Position Green		2.0 Amps @ 14 VDC			
A650PGD2	01-0770054-05		Position Green		1.0 Amps @ 28 VDC			
A650PRD1	01-0770054-06		Position Red		2.0 Amps @ 14 VDC			
A650PRD2	01-0770054-07		Position Red		1.0 Amps @ 28 VDC			
A650PGDM	01-0770054-14	Radio Shielded (Molex)	Position Green		1.0 Amps @ 28 VDC			
A650PRDM	01-0770054-15		Position Red					

### Installation

The A650 Series must be properly mounted to comply with FAR Part 91.205(c-2) & (c-3). The light assembly must be mounted so that the light distribution pattern is not obstructed by any parts of the aircraft. A limited amount of obstruction is permitted (Ref. FAR Part 23.1401 for anti-collision lights, and PAR 23.1387 for position lights).

The baseplate must be mounted parallel to the vertical and horizontal centerlines of the aircraft to project the patterns properly. These assemblies are interchangeable with the Grimes model A1285 position light.

### Mounting

1. If necessary, fabricate the mounting pattern using dimensions found in Figure 16b (**Note:** A 1" diameter hole is needed for the connector to pass through).
2. Make the necessary wiring connections using 18 gauge wire for the position lights, and Whelen Aerospace 16 gauge 3/c cable for the strobe lights. All connections must use FAA approved techniques.
3. Remove the (6-32 x .312) retainer mounting screw and retainer.
4. Attach the base assembly to the wingtip using (3) #6-32 counter-sunk screws (unit may be sealed around periphery with RTV or equivalent).
5. Re-attach lens retainer.

### Wiring

1. The strobe connector should plug into the Whelen Aerospace 16 gauge inter-connecting cable, or a Whelen Aerospace strobe power supply.

Observe the following strobe color coding:

**PIN 1 - RED** (Anode)  
**PIN 2 - BLACK** (Cathode)  
**PIN 3 - WHITE** (Trigger)

**Caution:** When pins 1 & 2 or pins 2 & 3 are reversed, the system will appear to operate normally, however this condition will cause pre-mature flash tube failure.

2. Connect the forward position light wires as follows, using 18 gauge approved aviation wire or cable:

**RED - +14 or +28 volts (depending on aircraft voltage)**  
**BLACK - (-) Ground**



### Dimensions

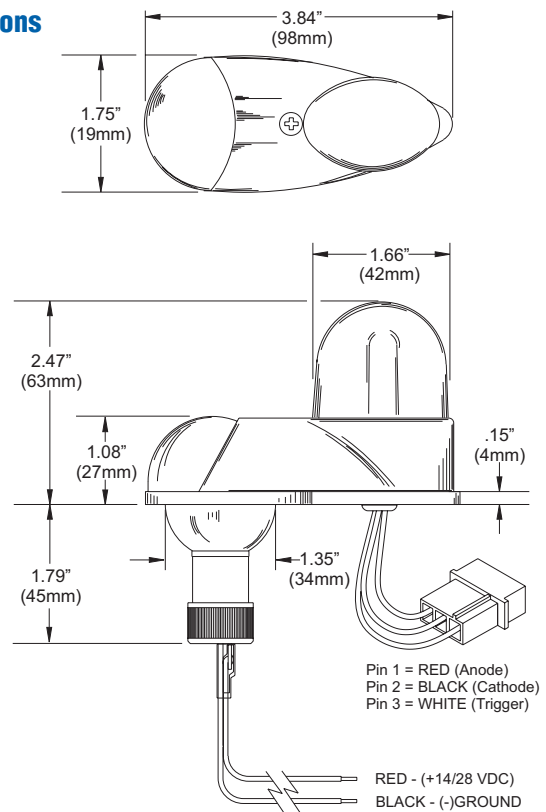

### Mounting Diagram

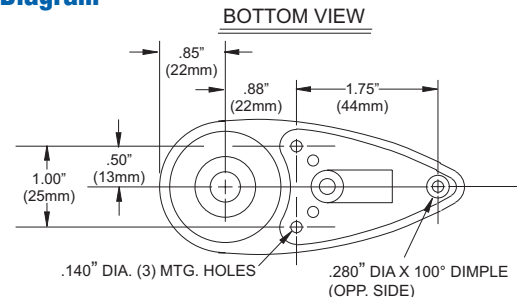





Before



After/With Modified Wingtip

### A650 Wingtip Strobe Light Installation on Later Model Cessna Wingtips with Shortened Light Base

Because Cessna has modified the Type E Series Wingtip Navigation Light, by cutting off the back 1.3 inch, and designed their wingtip to fit in closer to the light, it will be necessary to do a little fiberglass work when completing this installation. The A650 can be installed on these Cessnas in the manner below, and instructions above.

1. Remove the wingtip and the navigation light assembly.
2. Take a complete Model W1285 navigation light with an A650 head assembly installed, or an A650-PR or -PG, and place it in position on the wingtip. Mark around the navigation light base plate to get an outline of the navigation light profile on the wingtip.
3. File or trim away the excess wingtip material, to allow the navigation light and the A650 strobe light assembly to fit neatly in place. Allow at least 0.060 inch clearance around the A650 strobe head assembly and the wingtip.
4. To fill in the hole in the wingtip made by this trimming, and to provide a platform for the navigation and strobe light assembly, mount the navigational light base plate on the wingtip using the two (2) forward screws with a sheet of polyvinyl between the wingtip and the base plate for a parting agent. Tape the polyvinyl back over the wingtip to form a seal, so it is possible to apply a polyester resin putty, or epoxy putty like "Bondo", on the inside of the tip. Build up the trimmed area with this putty, as to have about 1/4 inch of material under and in back of the base plate. Prepare the surface and the putty material in accordance with the putty manufacturer's instructions, to assure a good bond to the wingtip.
5. Remove the navigation light base plate and parting agent.
6. To improve the appearance of this installation, fill the indentation on the outside of the wingtip with the aforementioned putty, and file the excess material to a clean profile before painting.
7. Drill the third mounting screw hole for the navigation light, and complete the installation, reference the enclosed information.



### A650 Replacement Parts Exploded View

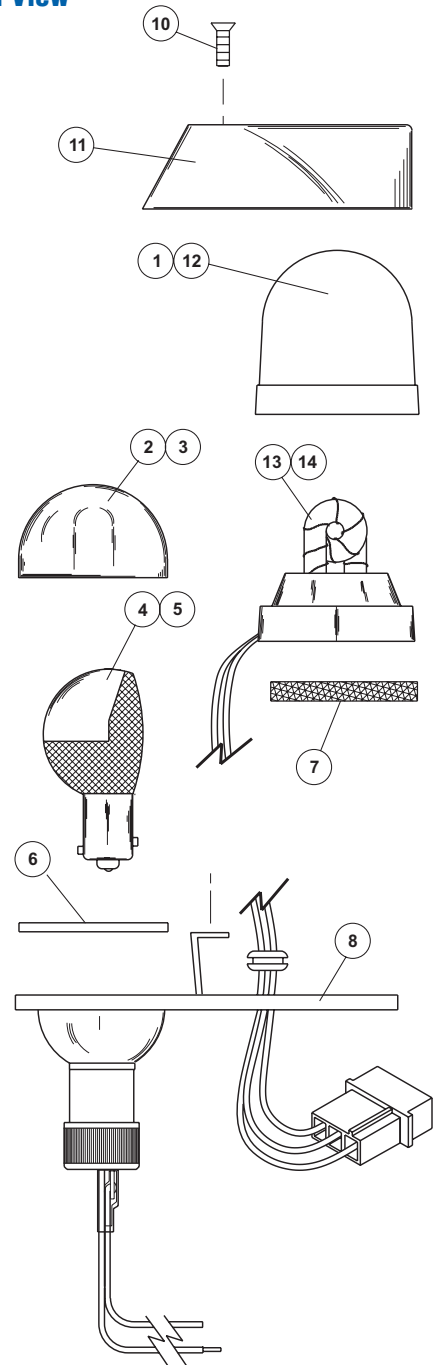

ITEM	PART NUMBER	DESCRIPTION
1	02-0350072-35	LENS, CLEAR (A626D)
2	68-4230020-50	LENS, RED (W1284R)
3	68-4230020-40	LENS, GREEN (W1284G)
4	34-0428020-65	LAMP, 28V (W1290-28)
5	34-0414020-65	LAMP, 14V (W129014)
6	38-0230021-00	GASKET, LENS (W1283)
7	38-0130106-00	GASKET, FLASHTUBE, (A427-3)
8	02-0350003-01	BASE PLATE ASSEMBLY (W1285-2)
10	N/A	#6-32 X 5/16 PHILLIPS FHMS(MS51959-27)
11	19-170052-009	RETAINER, LENS (A626)
12	68-2290005-30	LENS, FLASHTUBE (A612)
13	02-0250276-00	FLASH TUBE ASSEMBLY (A610)
14	02-0250276-03	FLASH TUBE ASSEMBLY (MOLEX CONNECTOR)

# LED LIGHT ASSEMBLIES

## 71110( ) SERIES WING TIP LED FORWARD POSITION LIGHT STROBE ASSEMBLY

71110 series is a wing tip mounted strobe anti-collision/position light assembly utilizing LED's for the forward position lights. The LED's provide a significant reduction in current draw over conventional position light bulbs. The strobe light lens assembly is radio shielded for maximum EMI/RFI protection. Direct replacement (exact footprint) for the Whelen Aerospace Model A650PG/PR series without replacing the current strobe power supply. Navigation light portion is wired with flying leads.



TSO-C30c TYPE I APPROVED  
TSO-C96a CLASS II APPROVED

### Model 71110( ) Specifications

Model Numbers	Part Number	Lens / Shielding	LED Color	Approvals	Operational Voltage	Nav Light Input Current	Weight	Exposed Height
7111001	01-0771110-01	Strobe (Color: White): RFI Coated Heat Resistant Glass Lens: (RFI Shielded)	Aviation Green	FAA TSO-C96a Class II / TSO-C30c Type II	14 VDC	0.25 Amps	0.50 lbs. (227gm) Nominal	2.70" (69mm)
7111002	01-0771110-02		Aviation Red	FAA TSO-C96a Class II / TSO-C30c Type I	14 VDC			
7111003	01-0771110-03	LED Navigation Lights: Clear Polycarbonate, Hard-coated Lens	Aviation Green	FAA TSO-C96a Class II / TSO-C30c Type II	28 VDC			
7111004	01-0771110-04		Aviation Red	FAA TSO-C96a Class II / TSO-C30c Type I	28 VDC			

### Operation

**EQUIPMENT LIMITATIONS:** An approved lighting system consists of two lights, one located on each wingtip. The baseplate must be mounted parallel to the vertical and horizontal centerlines of the aircraft to project the patterns properly. The strobe tube assembly must be connected to a strobe power supply, such as Whelen Aerospace model 70888, 70879 or other approved models.

**CONTINUED AIRWORTHINESS:** The 71110 series LED wingtip position light assembly is designed with 3 LED's. If any one LED fails, the unit must be repaired or replaced.

Inspect the lens. Replace if there is excessive scratching, discoloration or cracking.

**INSTALLATION PROCEDURES:** The following information is to assist in the installation of a Whelen Aerospace 71110 LED Forward Position Light/Strobe System.

1. Choose appropriate 71110( ) series replacement light assembly.
2. The installation procedure described in the following text will be confined to a single light installation, but is identical for multiple light installations.
3. Remove the old light, locate and save the existing +VDC lead and (-) ground lead. Clean and prep ends as required.
4. Make sure the existing system is equipped with an appropriate sized breaker. Connect the existing +14/ 28 VDC lead to the POSITIVE wire on the input cable assembly (supplied with the light assembly). Connect the existing ground lead to the GROUND wire on the input cable assembly or use the supplied connector as shown in the illustrations. Both leads must be connected by an approved FAA connection. Insure that the wire leads are clear of any obstructions and ty-wrap as required. Connect the strobe, J1, to the strobe power supply as shown in the figure.
5. Remove the shroud from the light assembly.
6. Position the base of the new light assembly onto the mounting surface. Insert three (3) #6-32 pan head screws into the mounting hole and tighten firmly.
7. Reinstall the lens so that the two notches are positioned under the shroud, with each notch equidistant to the centerline.
8. Check all avionics systems for interference from the installation.

9. A flight check should be performed by a properly certified pilot.

10. Update aircraft records, as required.

### Dimensions

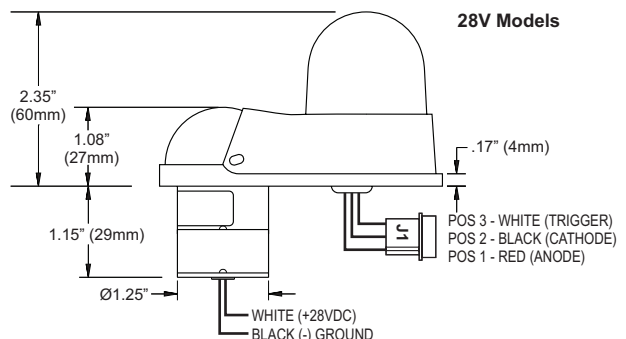
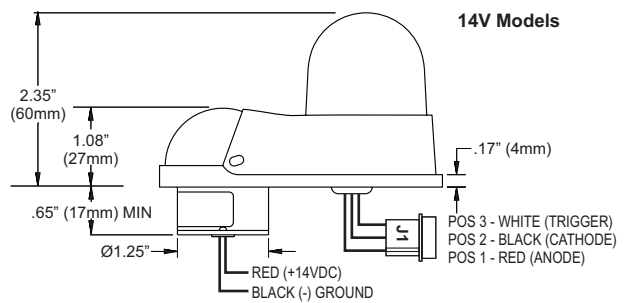
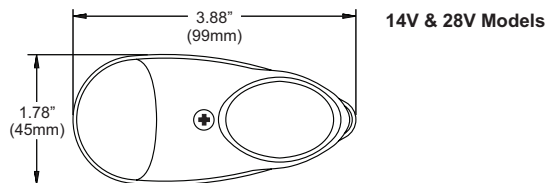



## INSTALLATION OF MODEL A612 with an A610 Flash Tube

A612 glass lens and A610 flash tube are used for installing wing tip strobes in single engine Cessna's 1972 and later. The existing position light retainer is modified to accommodate the lens, and the flash tube is mounted directly behind. The unique magnifying design of the A612 lens increases the light intensity by two to three times in the horizontal plane. These items may be used for custom installations or as spare parts for existing light assemblies. The A612 lens is available in Aviation Red and an RFI coated version. Lenses meet material requirements of MIL-C-7989B Class B.



Model A612 Specifications				
Model Numbers	Part Number	Lens	Approvals	Lens Weight
A612	68-2290005-30	Standard Clear Lens	—	0.08 lbs. (36gm)
A612C	68-2290005-34	Radio-shielded Clear/Coated Lens	—	
A612R	68-2290005-50	Aviation Red		
A612RC	68-2290005-54	Rfi Coated, Aviation Red Lens		



## MODEL A610 A610 flash tube.

Model A610 Specifications					
Model Numbers	Part Number	Mount	Approvals	Input Current / Operational Voltage	Flash Tube Weight
A610	02-0250276-00	Standard unit, 6" leads	—	Dependant on strobe power supply used	0.09 lbs. (41gm)
A610M	02-0250276-03	Molex connector, 6" leads			
5027601	02-0250276-01	14" leads			
5027602	02-0250276-02	A610 Style with 12-1/2" Leads			

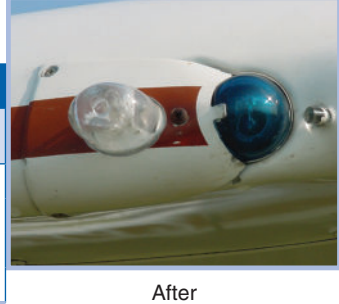

## Operation

The Model A610 flash tube and the Model A612 glass lens are used for installing wingtip strobes in single engine Cessna's 1972 and later. The existing position light retainer is modified to accommodate the lens, and the flash tube is mounted directly behind. The unique magnifying design of the A612 lens increases the light intensity by two to three times in the horizontal plane. Lenses meet material requirements of MIL-C-7989B class B.

## A610 Dimensions

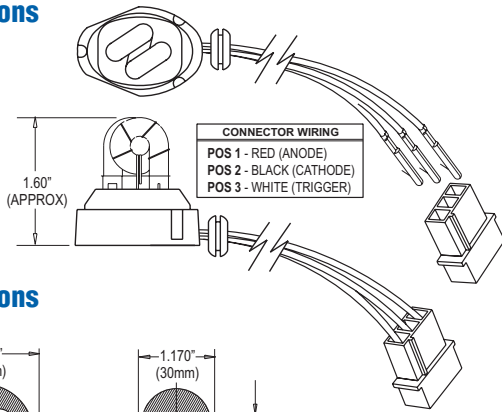

## A612 Dimensions

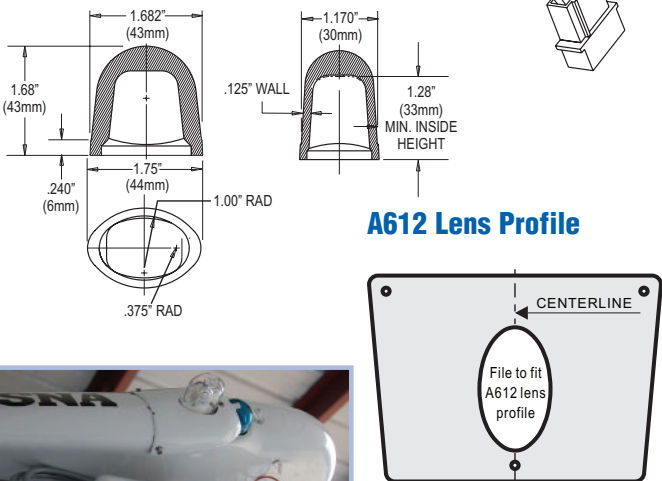

## Late Model Single Engine Cessna Wingtip Strobe Light Installation of A610 and A612

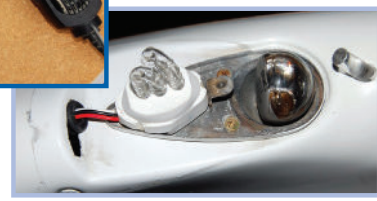

1. Remove the position light lens retainer being careful not to drop the Red or the Green lens.
2. Establish a center line on the Cessna lens retainer, referencing to the lens retainer center mounting screw, and position light base plate rear mounting screw.
3. Scribe the A612 lens profile as shown in illustration (Figure 40c, left), the object being to have the strobe light centered over the position light base plate.
4. Trim or fit an opening to the scribe line to fit the A612 lens. Due to the uneven surface of the Cessna lens retainer, the A612 will contact only the front and rear radius.
5. Place the sponge rubber pad supplied under the A610 flash tube to firm the assembly. RTV is recommended to secure lens in the modified retainer.
6. The flash tube interconnecting cable is routed through square holes in the rear bulkhead of the position light area.
7. Install the modified position light lens retainer, A610 flash tube and A612 lens, using original hardware.



## MODEL A625 SERIES INSTALLATION

A625 series has many different applications. It can be used for aircraft with tip-tanks with enclosed position lights (under a fairing), or as an add-on strobe on the wing or the tail. Available in a radio-shielded version.



### Model A625 Specifications

Model Numbers	Part Number	Mount	LENS / Color	Approvals	Input Current / Operational Voltage	Weight	Exposed Height
A625	01-0770058-03	Standard unit	Clear / White	FAA/PMA (-03 only)	Dependant on strobe power supply used	0.2 lbs. (91gm)	1.7" (43mm)
A625D	01-0770058-13	Radio shielded		—			
A625R	01-0770058-04	Standard unit	Red lens	—			
A625DR	01-0770058-14	Radio-shielded, red lens		—			
7005815	01-0770058-15	Radio-shielded, 3/c cable, 12" ground braid	Clear / White	—			
7005816	01-0770058-16	Radio-shielded, 24" 3/c cable, with MS connector		—			

### Dimensions

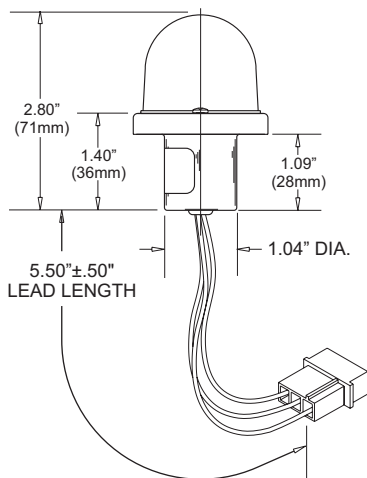

#### CONNECTOR WIRING

POS 1 - RED (ANODE)  
POS 2 - BLACK (CATHODE)  
POS 3 - WHITE (TRIGGER)

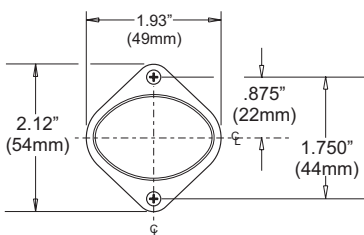

### Exploded View

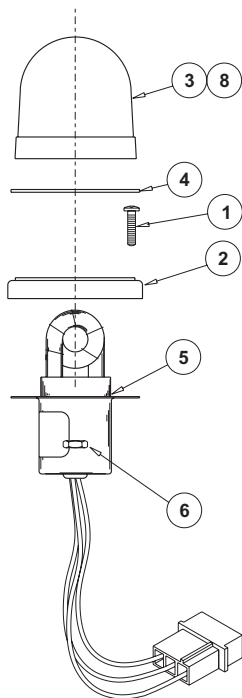

### A625 Strobe Light Assembly

The A625 strobe lighthouse assembly fits into a 1.1 inch hole. The mounting screws are 1.75 inch center to center. It protrudes 1.7 inch outside the aircraft's skin, and 1.1 inch inside the aircraft.

When installing an A625 strobe lighthouse assembly on the rudder, refer to the aircraft's MAINTENANCE and/or SERVICE MANUAL for accepted procedures for balancing the rudder before returning the aircraft to service.

Mount the anti-collision strobe lighthouse assembly as close to the stabilizer center line as practical, to eliminate backscatter as much as possible for the horizontal surface.

When installing the A625 strobe lighthouse assembly in an enclosed area like a Beech enclosed wingtip or tail cone, maintain at least 0.060 inch clearance around the lens to the plastic cover. The A625 mounts conveniently just behind the forward position light on Cessna's conical camber wingtip. Make sure that the navigation light pattern is not interrupted when installing the A625 strobe light head on a wingtip. The A612 lens is not considered an obstruction.



**A625 INSTALLATION IN CESSNA 300 OR 400 SERIES WINGTIP TANKS.** The A625 fits just under the navigation light, on an adapter plate of 0.032 inch aluminum, approximately 2-3/8 inches x 3-1/2 inches. Fit this plate between the navigation light and its mounting surface, and locate the A625 strobe head below the navigation light.

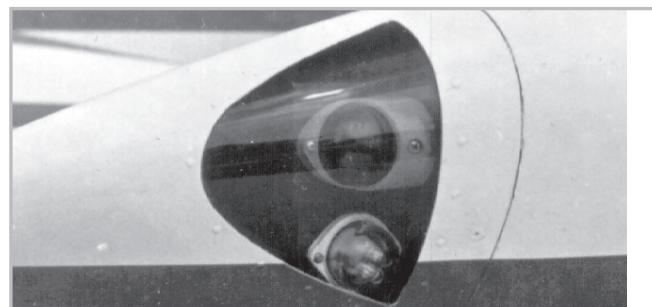

Bend and trim the adapter plate as necessary, so that the A625 clears the transparent window that covers the navigation light area 0.060 inch minimum.

The conduit for the navigation light wire is very small. To get the necessary wires to operate the strobe light and the navigation light through this conduit, use a 20 gauge wire, with less than 0.060 inch OD. It has been found that the Belden 8502 or 8308, has an 0.058 inch OD.

### Spare Parts

QTY	ITEM	PART NUMBER	DESCRIPTION
—	*	01-0770058-03	STROBE LIGHT ASSY. MODEL A625
*	—	01-0770058-13	STROBE LIGHT ASSY. MODEL A625D
2	2	1	N/A
—	1	2	19-170057-009 RETAINER, LENS
—	1	3	68-2290005-30 LENS, CLEAR (A612)
1	1	4	38-0250074-00 GASKET
1	1	5	02-0370338-00 A627 FLASHTUBE ASSY.
2	2	6	N/A
1	—	8	68-2290005-34 LENS, RFI COATED (A612C)

## MODEL A500A SERIES INSTALLATION

A500A Series Combination Strobe/Tail Navigation light used when the wingtip Anti-Collision lights are mounted in an enclosure and can't provide 360° of strobe coverage. It is a direct replacement for the standard Tail Position light. Available in a radio-shielded version. Voltage (14 or 28) and mounting (horizontal or vertical) must be specified when ordering.

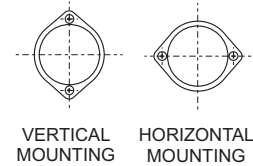

### Model A500A Specifications

Model Numbers	Part Number	Mount	LENS Color	Approvals	Operational Voltage	Nav Light Input Current	Weight	Exposed Height / Diameter
A500AV14	01-0770024-00	Vertical Mount	Clear Glass	FAA/PMA FAA TSO-C30b	14 VDC	1.8	0.3 lbs. (136gm)	1.7" (43mm) / 1.5" (38mm)
A500AV28	01-0770024-01	Vertical Mount			28 VDC	.9		
A500AH14	01-0770024-02	Horizontal Mount			14 VDC	1.8		
A500AH28	01-0770024-03	Horizontal Mount			28 VDC	.9		
A500AVD1	01-0770024-04	Vertical Mount, Radio-shielded			14 VDC	1.8		
A500AVD2	01-0770024-05	Vertical Mount, Radio-shielded			28 VDC	.9		
A500AHD1	01-0770024-06	Horizontal Mount, Radio-shielded			14 VDC	1.8		
A500AHD2	01-0770024-07	Horizontal Mount, Radio-shielded			28 VDC	.9		
A500VDM1	01-0770024-08	Vertical Mount, Molex Conn., Shielded			14 VDC	1.8		
A500VDM2	01-0770024-09	Vertical Mount, Molex Conn., Shielded			28 VDC	.9		
A500HDM1	01-0770024-10	Horizontal Mount, Molex Connector			14 VDC	1.8		
A500HDM2	01-0770024-11	Horizontal Mount, Molex Connector			28 VDC	.9		
A500ABV2	01-0770024-15	Vertical Mount, with MS Connector, Beech Special			28 VDC	1.8		
A500ABV1	01-0770024-16	Vertical Mount, with MS Connector, Beech Special			14 VDC	.9		
A500ASP2	01-0770024-25	Vertical Mount, 50' cables, no connectors, Beech Special			28 VDC	1.8		

### Operation

Combination Strobe/Tail Navigation Light used when the wingtip Anti-Collision lights are mounted in an enclosure and can't provide 360° of strobe coverage. It is a direct replacement for the standard Tail Position light. Available in a radio-shielded version. Voltage (14 or 28), and mounting, (horizontal or vertical) must be specified when ordering.

### Dimensions

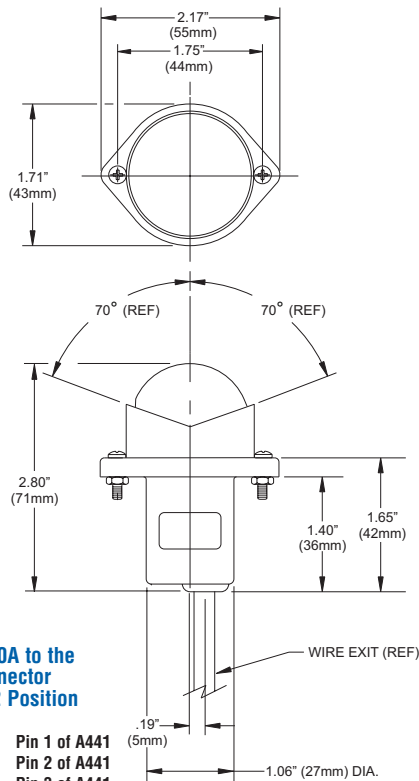

### Connecting Wiring of the A500A to the A441 Amp 3 Position Pin Connector Housing, and the A444 Amp 2 Position Pin Housing Connector.

Anode RED wire  
Cathode BLACK wire  
Trigger WHITE wire  
Position Light A+ BLUE wire  
Position Light Ground BLUE wire

Pin 1 of A441  
Pin 2 of A441  
Pin 3 of A441  
Pin 1 of A444  
Pin 2 of A444

### Installation

1. Remove the Model S tail position light by removing the two (2) retainer ring screws.



2. This unit fits directly in place of the Grimes Model S tail position light. It is however sometimes necessary to open the mounting hole in the aircraft fairing to 1.10 inch, to clear the body of the A500A. The body protrudes 1.40 inch into the tail fairing.
3. Establish the proper light pattern of the A500A tail position light. The retainer shield must be located so that the bottoms of the V notches are vertical (parallel to the rudder) to shadow the light so it will produce a horizontal light pattern of 70 degrees left & right of straight back of aircraft.

### Mounting

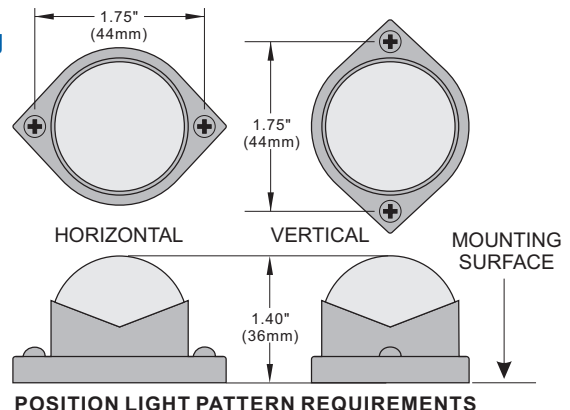



# Model A500A SERIES

## Exploded View Parts

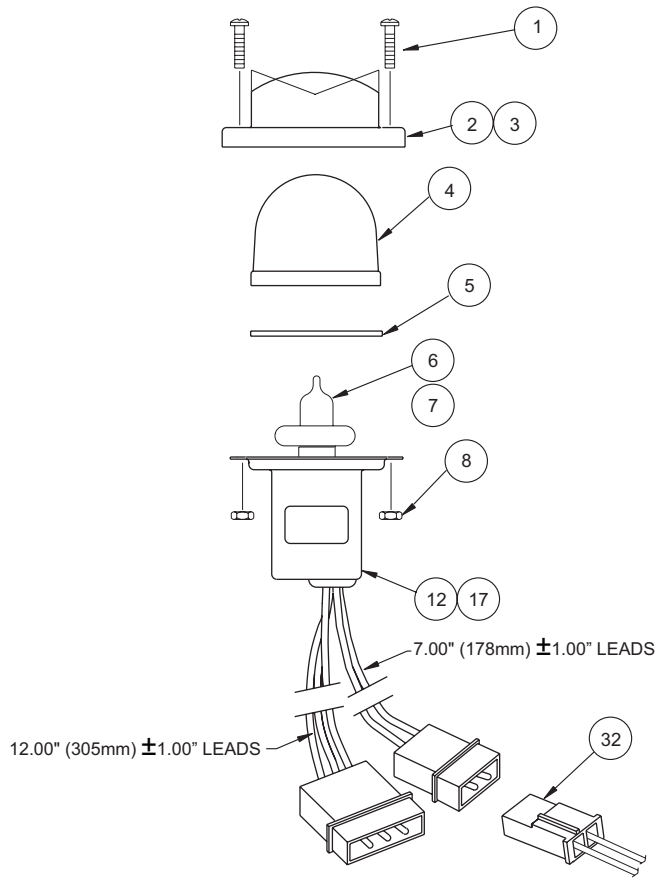

- A500AV14 (01-0770024-00)
- A500AV28 (01-0770024-01)
- A500AH14 (01-0770024-02)
- A500AH28 (01-0770024-03)

- A500AVD1 (01-0770024-04)
- A500AVD2 (01-0770024-05)
- A500AHD1 (01-0770024-06)
- A500AHD2 (01-0770024-07)
- A500VDM1 (01-0770024-08)
- A500VDM2 (01-0770024-09)
- A500HDM1 (01-0770024-10)
- A500HDM2 (01-0770024-11)
- A500ABV2 (01-0770024-15)
- A500ABV1 (01-0770024-16)
- A500ASP2 (01-0770024-25)

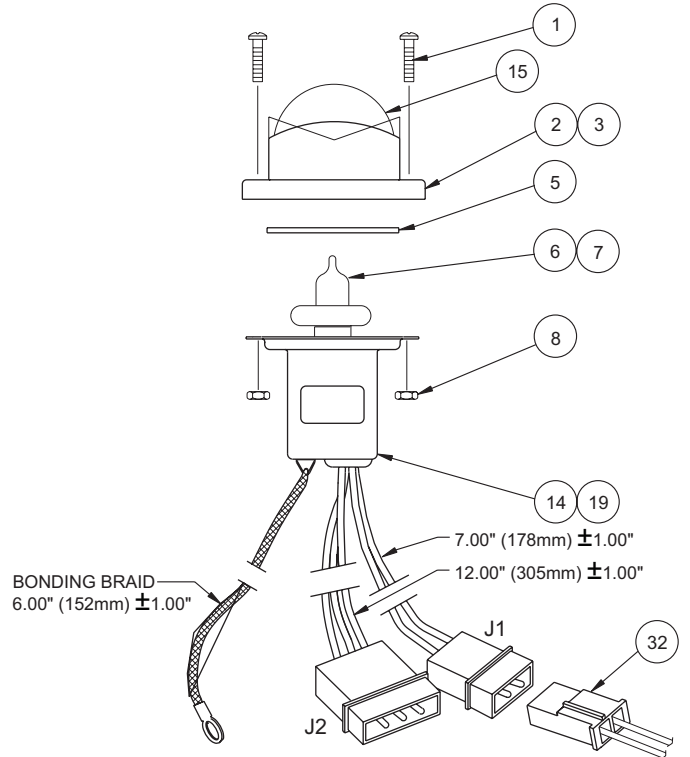

**J2 CONNECTOR WIRING**  
 POS 1 - RED(ANODE)  
 POS 2 - BLACK(CATHODE)  
 POS 3 - WHITE(TRIGGER)

**J1 CONNECTOR WIRING**  
 POS 1 - BLUE(+)  
 POS 2 - BLUE(-)GROUND



Model A500A Installation

### Model A500A Parts List

QTY	QTY	QTY	QTY	QTY	QTY	QTY	QTY	ITEM	PART NUMBER	DESCRIPTION
							*		01-0770024-00	Tail Pos & Strobe LT Assy (A500A-V-14)
							*		01-0770024-01	Tail Pos & Strobe LT Assy (A500A-V-28)
							*		01-0770024-02	Tail Pos & Strobe LT Assy (A500A-H-14)
							*		01-0770024-03	Tail Pos & Strobe LT Assy (A500A-H-28)
			*						01-0770024-04	Tail Pos & Strobe LT Assy (A500A-V-D-14)
	*								01-0770024-05	Tail Pos & Strobe LT Assy (A500A-V-D-28)
	*								01-0770024-06	Tail Pos & Strobe LT Assy (A500A-H-D-14)
*									01-0770024-07	Tail Pos & Strobe LT Assy (A500A-H-D-28)
2	2	2	2	2	2	2	2	1	- = N/A	#4-40 x 1/2 Phillips PHMS (MS51957-17)
-	-	-	-	1	1	-	-	2	19-0150350-01	Retainer, Mask (Horizontal)
-	-	-	-	-	1	1	1	3	19-0150350-02	Retainer, Mask (Vertical)
-	-	-	-	1	1	-1	1	4	68-4270002-30	Clear Glass Plain Dome (A457A)
1	1	1	1	1	1	1	1	5	38-0230002-00	Gasket (A455)
-	1	-	1	-	1	-	1	6	34-0412070-63	Lamp, Erc Halogen (14 Volt) (A508-14)
1	-	1	-	1	-	1	-	7	34-0428070-64	Lamp, Esg Halogen (28 Volt) (A508-28)
2	2	2	2	2	2	2	2	8	- = N/A	Hex Nut, #4-40 X 1/4 A.F. Brass
-	-	-	-	1	1	1	1	12	02-0350034-00	Flash Tube And Socket Assy (A506)
1	1	1	1	-	-	-	-	14	02-0350375-00	Flash Tube And Socket Assy (A506D)
1	1	1	1	-	-	-	-	15	68-4270002-34	Lens, RFI Coated (A457AC)
-	-	-	-	-	-	-	-	19	02-0350375-01	Flash Tube And Socket Assy (A506DM)
1	1	1	1	1	1	1	1	32	46-0750698-00	Pigtail

# LED LIGHT ASSEMBLIES

## MODEL 71011 ( ) SERIES LED TAIL POSITION LIGHT ASSEMBLY

71011 series are LED tail position lights designed to replace the existing "old style" tail lights typically seen mounted on most general aviation, corporate, and helicopter applications. They have all the advantages associated with using LED's as a light source, improved reliability, and reduced operating costs and are available with horizontal or vertical mounts with 14 Volt or 28 Volt versions.



### Model 71011 ( ) Specifications

Model Numbers	Part Number	Mount	Voltage	LED Color	Approvals	Operational Voltage	Input Current	Weight	Exposed Height	Mounting Hole Pattern
7101102	01-0771011-02	Vertical	28 VDC	Aviation White	FAA TSO-C30c Type III	22-30 VDC	0.3 Amps	0.2 lbs. (91gm)	1.36" (35mm)	1.75" (45mm)
7101103	01-0771011-03	Horizontal								
7101112	01-0771011-12	Vertical	14 VDC							
7101113	01-0771011-13	Horizontal								

### Operation

**Equipment Limitations:** The approved tail position light assembly should be mounted vertically and as far aft on the aircraft as possible, on a thermally conductive surface.

**Continued Airworthiness:** The LED tail position light assembly is designed with 6 LED's. If any one LED fails, the unit must be repaired or replaced. Inspect the lens. Replace if there is excessive scratching, discoloration or cracking.

**Installation Procedures:** The following information is to assist you in installing a Whelen Aerospace tail position light.

1. Choose the appropriate model light assembly which is most applicable to your aircraft.
2. Remove the old light, locate and save the existing +28VDC lead and (-) ground lead (7101102 & 7101103). Clean and prep ends as required.
3. Use the existing mounting holes and hardware.
4. For Model 7101101, secure the existing connector onto the base of the light assembly. For Models 7101102 & 7101103, connect the existing +28 VDC lead to the White 20 AWG lead on the input cable assembly (supplied with light assembly). Connect the existing ground lead to the Black 20 AWG wire on the input cable assembly. If a chassis ground wire exists on the aircraft, connect it to the chassis ground wire assembly. Both leads must be connected by FAA approved techniques using approved hardware.
5. Make sure the existing system is equipped with an appropriate sized breaker.
6. Remove two #4-40 screws from taillight assembly. Save these screws.
7. Install the light assembly and insure that all the leads are clear of any obstructions and ty-wrap as required. Secure light assembly using approved vibration resistant hardware methods.  
**Note:** "Top" marking on the unit.
8. Re-mount the lens and retainer onto the assembly. Attach the lens and retainer with mounting screws (provided).
9. Check all avionics systems for interference from this installation.
10. When waterproofing the assembly to the aircraft, apply aviation approved single part silicone (RTV) or equivalent around the periphery with caution. Do not fill the

### Operation (cont'd)

drain holes at bottom of unit. **RTV should never be used between the rear surface of the light assembly and its mounting surface.**

11. Update aircraft records, as required and obtain FAA field approval for installation, **if not covered under STC eligibility list.**

### Dimensions and Mounting Detail

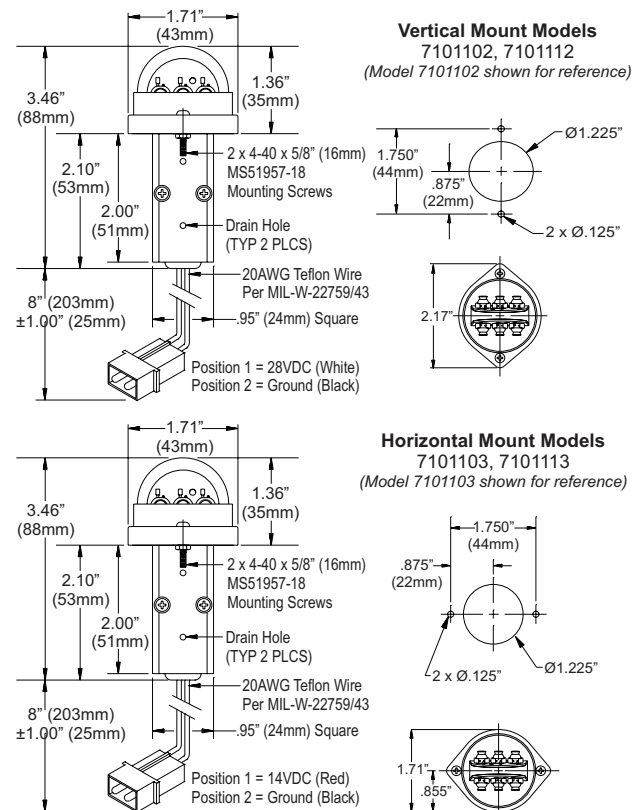

## Model 71011 ( ) Series Exploded View Parts

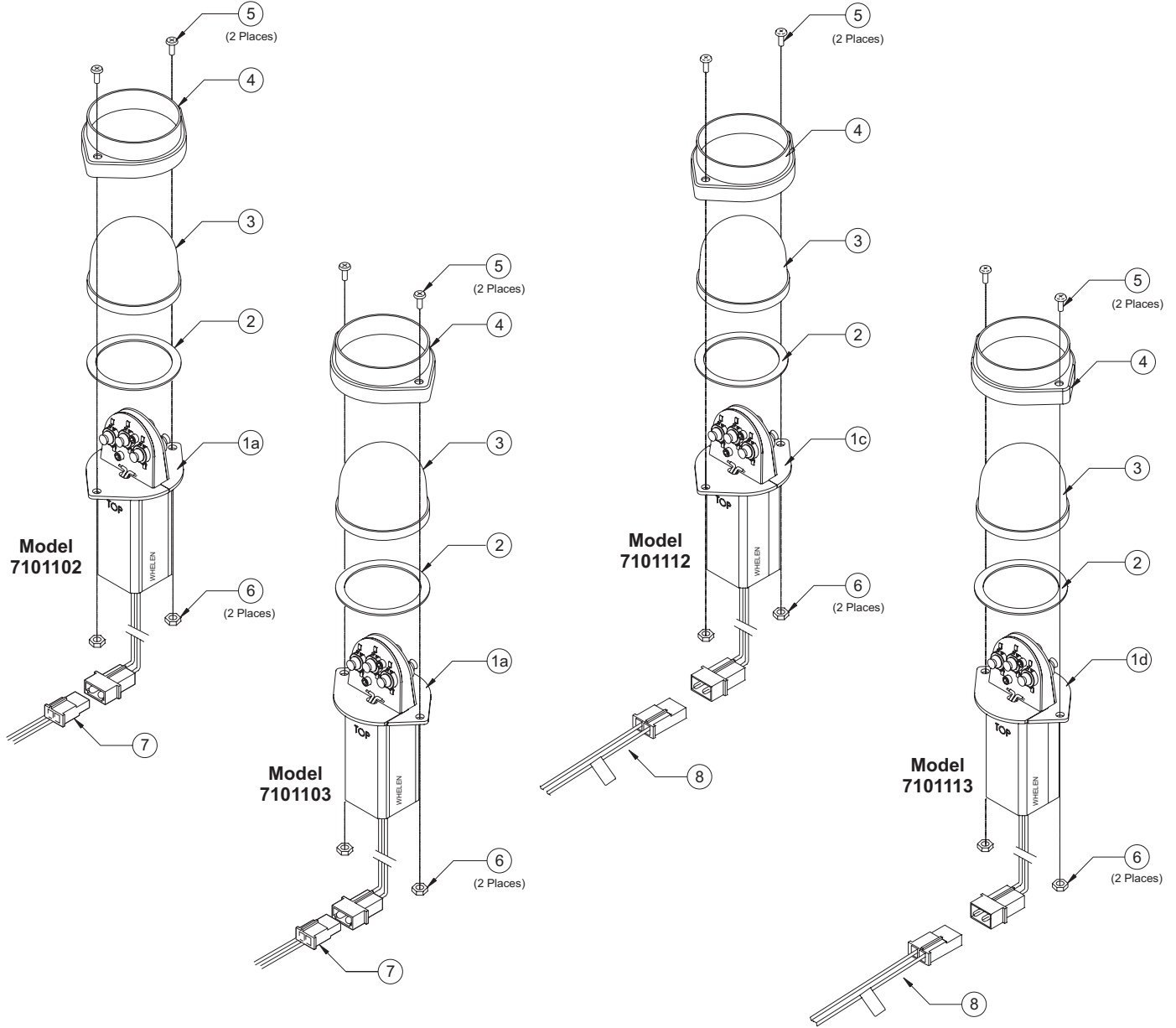

### Model 71011 ( ) Series Parts List

QTY	ITEM	PART NUMBER	DESCRIPTION
*	*	01-0771011-02	MODEL 7101102 LED TAIL POSITION LIGHT FINAL ASSEMBLY 28VDC
*	*	01-0771011-03	MODEL 7101103 LED TAIL POSITION LIGHT FINAL ASSEMBLY 28VDC
*	*	01-0771011-12	MODEL 7101112 LED TAIL POSITION LIGHT FINAL ASSEMBLY 14VDC
*	*	01-0771011-13	MODEL 7101113 LED TAIL POSITION LIGHT FINAL ASSEMBLY 14VDC
1	1a	01-0290307-02	ASSY, LED VERTICAL MOUNT TAIL POSITION LIGHT (28V)
1	1b	01-0290307-03	ASSY, LED VERTICAL MOUNT TAIL POSITION LIGHT (28V)
1	1c	01-0290307-12	ASSY, LED HORIZONTAL MOUNT TAIL POSITION LIGHT (14V)
1	1d	01-0290307-13	ASSY, LED HORIZONTAL MOUNT TAIL POSITION LIGHT (14V)
1	2	38-0231061-00	GASKET, LENS LED TAIL POSITION LIGHT
1	3	68-3970991-30	LENS, CLEAR TAIL POSITION LIGHT
1	4	19-0150350-03	RETAINER MASK, .635 TALL
2	5	14-0050505-18	SCREW, 4-40 x 5/8 PPHMS MS51957-18
2	6	13-040130-040	NUT, 4-40 x 1/4 HEX BRASS (for shipping)
1	7	46-0750898-00	28V PIGTAIL ASSEMBLY, 6" (BLK/WHT)
1	8	46-0750898-01	14V PIGTAIL ASSEMBLY, 6" (BLK/RED)



# LED LIGHT ASSEMBLIES

## MODEL 71554 ( ) SERIES LED TAIL POSITION LIGHT ASSEMBLY

71554 Series in our newest LED Tail Position Light. **Exact Footprint for Whelen Aerospace Models A555A and 71011 Taillights.** Available in horizontal or vertical mount.



TSO-C30c TYPE III  
APPROVED

### Model 71554 ( ) Specifications

Model Numbers	Part Number	Mount	Voltage	LED Color	Approvals	Operational Voltage	Input Current	Weight	Exposed Height	Mounting Hole Pattern
7155401	01-0771554-01	Horizontal	28 VDC	Aviation White	FAA TSO-C30c/ ETSO-C30c Type III	22-30 VDC	0.125 Amps	0.17 lbs. (91gm)	1.36" (35mm)	1.75" (45mm)
7155402	01-0771554-02	Vertical								
7155411	01-0771554-11	Horizontal	14 VDC							
7155412	01-0771554-12	Vertical								

### Operating Instructions

**EQUIPMENT LIMITATIONS:** An approved tail position light assembly should be mounted as far aft on the aircraft as practicable on a thermally conductive surface. The baseplate must be mounted parallel to the vertical and horizontal centerlines of the aircraft to project the patterns properly.

Certain types of installations may require additional testing.

**CONTINUED AIRWORTHINESS:** The 71554 ( ) series LED tail position light assembly is designed with 6 LEDs. Should any one LED fail the unit must be repaired or replaced. **Note:** To reduce eye strain, use an optical filter such as dark glasses or a Blue covering dome during LED inspection. Inspect the lens. Replace if there is excessive scratching, pitting, discoloration or cracking.

**INSTALLATION PROCEDURES:** The following information is to assist you in installing a Whelen Aerospace LED tail position light.

1. Choose the appropriate 71554 ( ) light assembly.
2. Using the mounting detail information provided, prepare the aircraft for means to secure the LED light assembly.
3. Connect the position light inputs according to the chart shown. Connect the power lead to an appropriate sized breaker. Connections to be in accordance with FAA approved methods.
4. Remove and discard the two screws and nuts holding the retainer to the unit. Carefully remove the lens retainer and lens from the assembly. **CAUTION! Do not touch the LED surface with either fingers or sharp objects.** This could soil or damage the lens and effect the optical performance of the LEDs.
5. Install light assembly and insure that all leads are clear of any obstructions. Note that proper orientation is achieved with the drain hole down.
6. Reinstall the lens and confirm proper gasket fit.
7. Install the lens retainer. Using appropriate hardware secure as required. Secure light assembly using vibration resistant threaded fasteners.
8. When necessary, waterproof the light base to aircraft. Apply single part silicone (RTV) or equivalent around any open area where water could get in. Do not cover drain hole.
9. Check all avionics systems for interference from this installation.
10. A flight check should be performed by a properly certified pilot.

### Operation (cont'd)

11. Update aircraft records, complete Form 337 and obtain FAA field approval for installation, as necessary.

### Dimensions and Mounting Detail 14 VDC

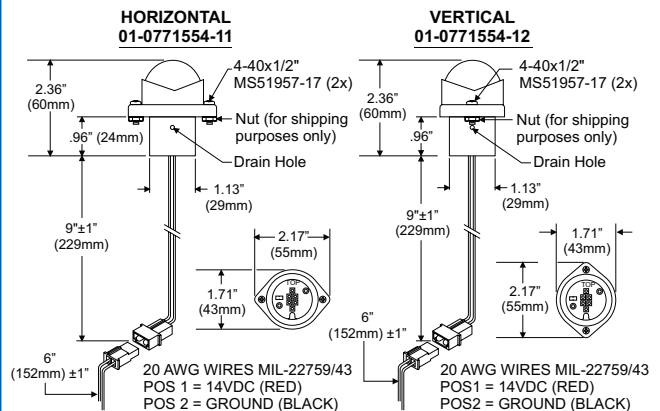

### Mounting Detail

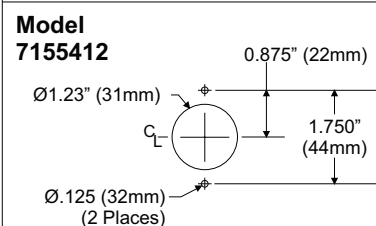
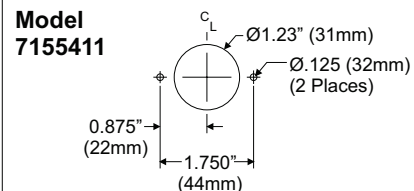



## Dimensions and Mounting Detail 28 VDC

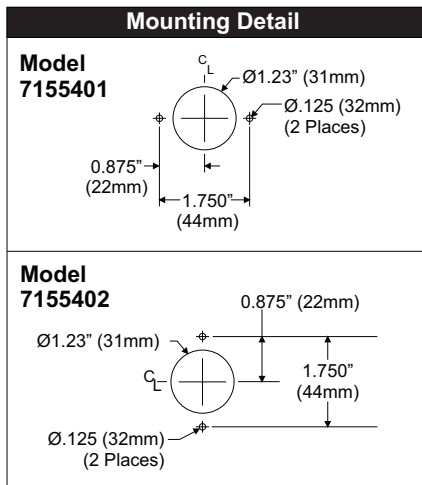
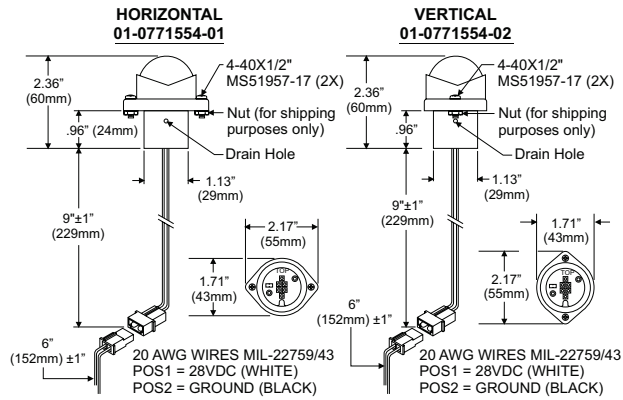

## Model 71554 Series Exploded View Parts

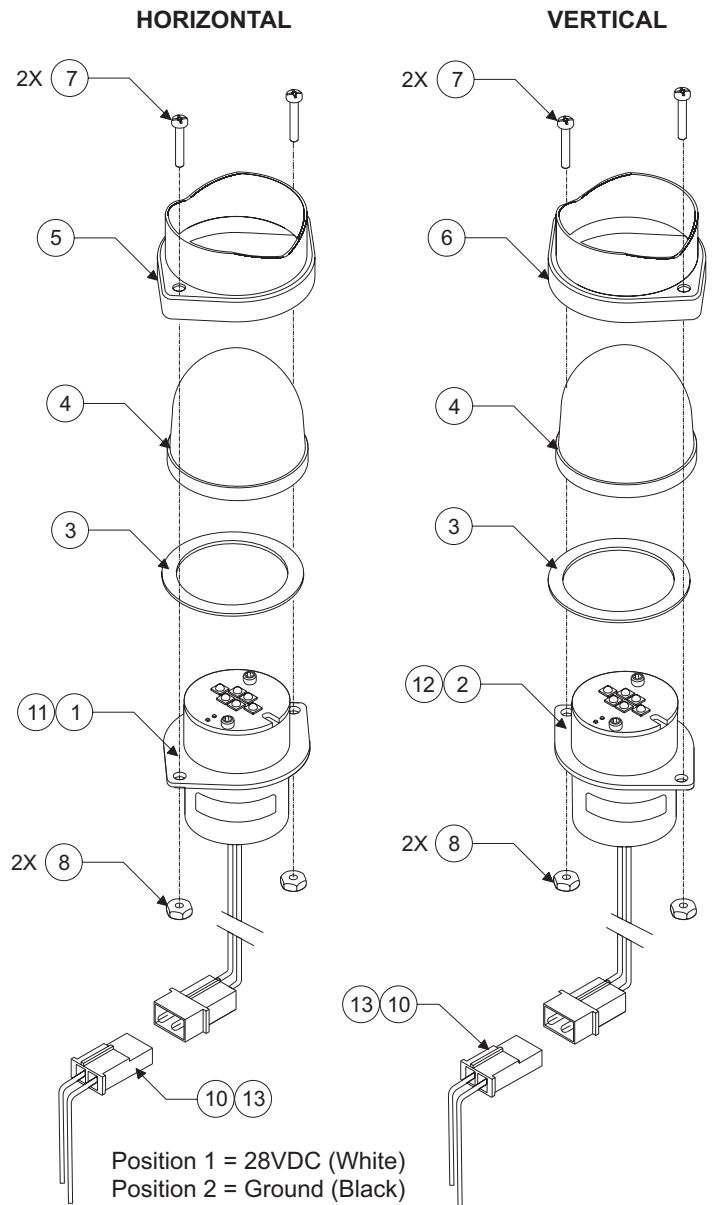

### Model 71554( ) Series Parts List

QTY	QTY	QTY	QTY	ITEM	PART NUMBER	DESCRIPTION
			*		01-0771554-01	Final, 28V LED Tail Pos Light Horizontal
			*		01-0771554-02	Final, 28V LED Tail Pos Light Vertical
	*				01-0771554-11	Final, 14V LED Tail Pos Light Horizontal
*					01-0771554-12	Final, 14V LED Tail Pos Light Vertical
—	—	—	1	1	01-0271552-01	Assy, 28V LED Tail Pos Light Horizontal
—	—	1	—	2	01-0271552-02	Assy, 28V LED Tail Pos Light Vertical
1	1	1	1	3	38-0231260-00	Gasket, Lens 90296 Housing
1	1	1	1	4	68-3970991-30	Lens, Clear Hard-coat Tail Position Light
—	1	—	1	5	19-0150350-06	Retainer Mask, Horizontal
1	—	1	—	6	19-0150350-07	Retainer Mask, Vertical
2	2	2	2	7	14-0050505-18	Screw, 4-40 x 5/8 PPHMS MS51957-18
2	2	2	2	8	13-040130-040	Nut, 4-40 x 1/4 Hex Brass
1	1	1	1	10	46-0750898-00	Ass'y, 28V Pigtail 6" Blk/Wht
—	1	—	—	11	01-0271552-11	Assy, 14V LED Tail Pos Light Horizontal
1	—	—	—	12	01-0271552-12	Assy, 14V LED Tail Pos Light Vertical
1	1	1	1	13	46-0750898-01	Ass'y, 14V Pigtail 6" Blk/Red

## MODEL A600 PG/PR SERIES INSTALLATION

A600 PG/PR series wing tip anti-collision, forward position and tail position lights, all in one compact unit. Tail position light eliminates the need for a tail mounted position light. Available in 14 or 28 VDC and in a radio-shielded version. The forward position lamp is 26 watts and the taillight lamp is 25 watts.



### Model A600 PG/PR Specifications

Model Numbers	Part Number	Mount	LENS / Color	Approvals	Nav Light Input Current / Operational Voltage	Strobe Input Current	Weight	Exposed Height / Length / Width
A600PG1	01-0790006-00	Position Green	Green	FAA TSO-C30b / FAA/PMA	4.0 amps @ 14 VDC	Dependant on strobe power supply used	0.8 lbs. (363gm)	2.4" (61mm) / 5.63" (143mm) / 1.7" (43mm)
A600PG2	01-0790006-01	Position Green			2.0 amps @ 28 VDC			
A600PR1	01-0790006-02	Position Red	Red		4.0 amps @ 14 VDC			
A600PR2	01-0790006-03	Position Red			2.0 amps @ 28 VDC			
A600PGD1	01-0790006-04	Position Green, Radio-shielded	Green		4.0 amps @ 14 VDC			
A600PGD2	01-0790006-05	Position Green, Radio-shielded			2.0 amps @ 28 VDC			
A600PRD1	01-0790006-06	Position Red, Radio-shielded	Red		4.0 amps @ 14 VDC			
A600PRD2	01-0790006-07	Position Red, Radio-shielded			2.0 amps @ 28 VDC			

### Operation

Wingtip anti-collision, forward position, and tail position lights, all in one compact unit. Tail position light eliminates the need for a tail mounted position light. Available in 14 or 28 volts, and in a radio-shielded version. The forward position lamp is 26 watts and the taillight lamp is 25 watts.

### Installation

The A600 Series must be properly mounted to comply with FAR Part 91.205(c-2) & (c-3). The light assembly must be mounted so that the light distribution pattern is not obstructed by any parts of the aircraft. A limited amount of obstruction is permitted (Ref. FAR Part 23.1401 for anti-collision lights, and PAR 23.1387 for position lights).

The convergence of the two wingtip tail position must occur within 1200 feet directly behind the aircraft to comply with field of coverage requirements. The baseplate must be mounted parallel to the vertical & horizontal centerlines of the aircraft to project the patterns properly.

### Mounting

1. If necessary, fabricate the mounting pattern using dimensions found in Figure 40a.
2. Make the necessary wiring connections using 18 gauge wire for the position lights, and Whelen Aerospace 16 gauge 3/c cable for the strobe lights. All connections must use FAA approved techniques.
3. Remove the two (6-32 x .312) retainer mounting screws and retainer.
4. Attach the base assembly to the wingtip using (3) #6-32 counter-sunk screws (unit may be sealed around periphery with RTV or equivalent).
5. Re-attach lens retainer (see Figure 48a).

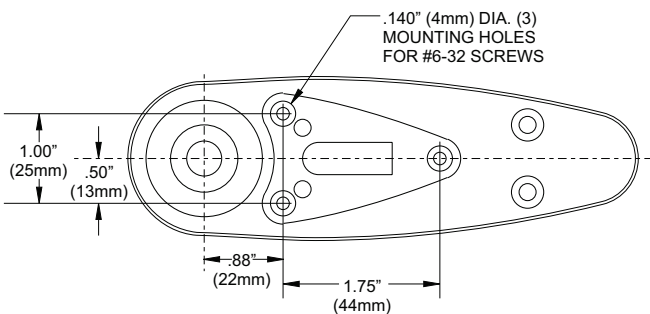

### Wiring

1. The strobe connector should plug into the Whelen Aerospace interconnecting cable, or a Whelen Aerospace strobe power supply.

Observe the following strobe color coding:

- PIN 1 - RED** (Anode)
- PIN 2 - BLACK** (Cathode)
- PIN 3 - WHITE** (Trigger)

**Caution:** When pins 1 & 2 or pins 2 & 3 are reversed, the system will appear to operate normally, however this condition will cause pre-mature flash tube failure.

2. Connect the forward position light wires as follows:

**RED - +14 or +28 volts (depending on aircraft voltage)**  
**BLACK - (-) Ground**

3. The tail position light has no polarity, as noted by both wires being BLUE. Connect one BLUE wire to +14 or +28 volts (depending on aircraft voltage). Connect the other BLUE wire to ground (see Figure 48b).

### Dimensions

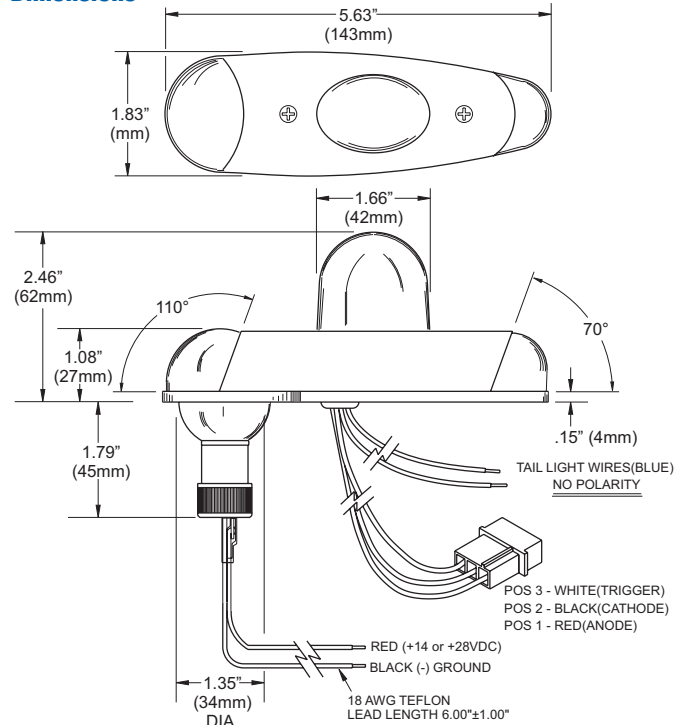



# Model A600 SERIES

## Exploded View Parts

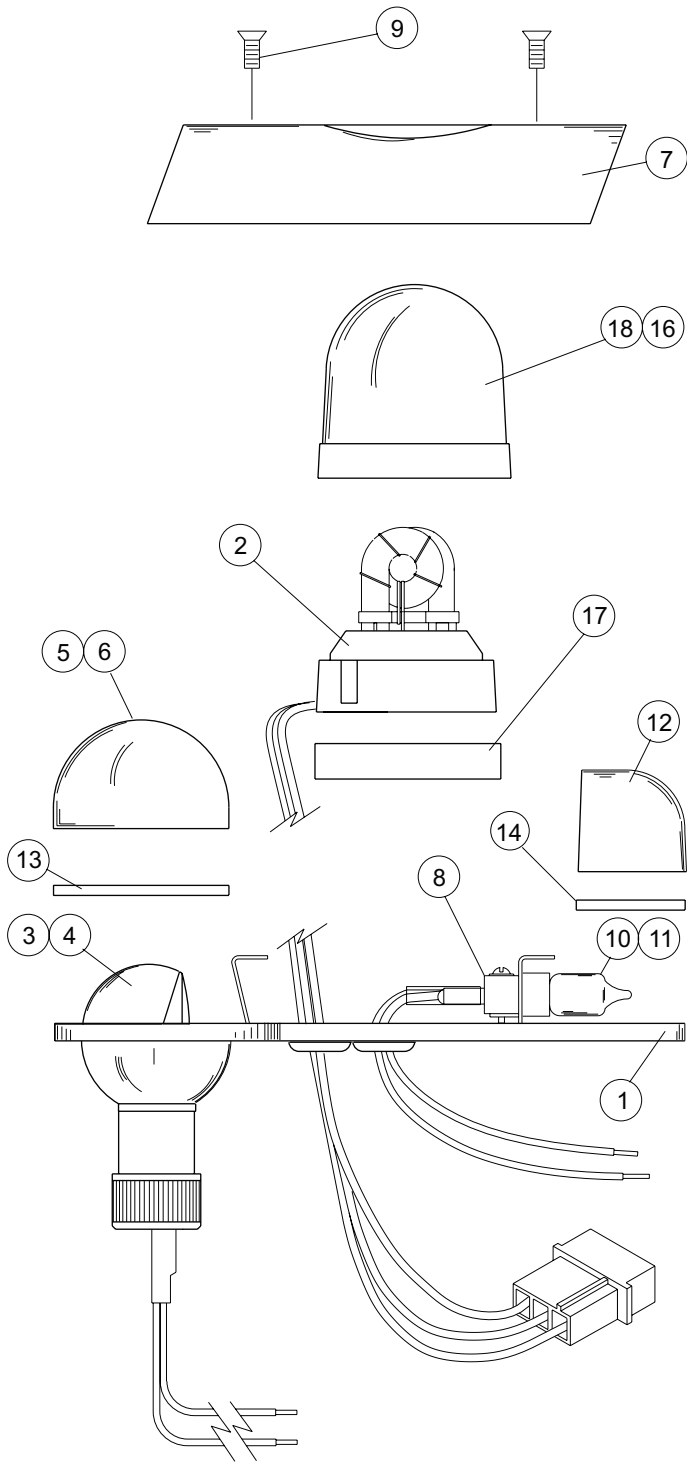

### Model A600 Series Replacement Parts List

ITEM	PART NUMBER	DESCRIPTION
1	02-0350259-00	BASEPLATE ASSY. (A605)
2	02-0250276-00	FLASH TUBE ASSEMBLY (A610)
3	34-0414020-65	LAMP, 14V (W1290-14)
4	34-0428020-65	LAMP, 28V (W1290-28)
5	68-4230020-40	LENS, GREEN (W1284-G)
6	68-4230020-50	LENS, RED (W1284-R)
7	19-170049-009	LENS RETAINER (A606)
8	02-0350260-00	SOCKET ASSY. (A507)
9	N/A	#6-32 X 5/16 PHILLIPS FHMS (MS51959-27)
10	34-0412070-63	LAMP, 14V (A508-14)
11	34-0428070-64	LAMP, 28V (A508-28)
12	68-4250066-30	LENS, TAIL POSITION (A615)
13	38-0230021-00	GASKET (W1283)
14	38-0130090-00	GASKET (A616)
16	68-2290005-34	LENS, RFI COATED (A612C)
17	38-0130107-00	GASKET (A427-4)
18	68-2290005-30	LENS, CLEAR (A612)



Model A600 Installation

## MODEL A650 SERIES INSTALLATION

A650 series converts W1285 position lights into a position/anti-collision system by removing the existing retainer & replacing it with the A650 assembly. Radio-shielded version available.



### Model A650 Specifications

Model Numbers	Part Number	Description	Color	Approvals	Weight	Exposed Height
A650	01-0770053-00	Standard Unit	Aviation White	FAA / PMA	0.2 lbs. (91gm)	2.4" (61mm)
A650D	01-0770053-13	Radio-shielded				

### A650 Operation

Converts existing Whelen W1285 position lights into a position/anti-collision light system by removing the existing retainer and replacing it with the A650 assembly. Available in a radio-shielded version.

#### A650 Wingtip Strobe Light.

To install the Whelen A650 strobe lighthouse assembly on the aircraft, proceed with the following instructions:

1. Remove the wingtip navigation light and wingtip, when necessary.
2. Install the nylon three position AMP pin connectors A441 on the end of the flash tube wires (RED in pin 1, BLACK in pin 2, and WHITE in pin 3).
3. Assemble the navigation light assembly on the wingtip using the A650 strobe light assembly as the navigation light lens retainer.
  - a. Install the rubber pad (supplied in kit) on the position light base plate under the A610 flash tube, if necessary to make the lens firm in its mounting.
4. In some installations it will be necessary to mask the A650 strobe light, to reduce pilot annoyance. The Navigation Light Detector will be a source of reflection, and should be reduced in size or masked as necessary. A small aluminum or plastic plate, mounted between the navigation light and the wingtip, protruding up or down as required (like some plastic navigation light detectors), and trimmed to shadow the objectionable reflected area, is most effective. This reflection problem varies from one aircraft to another, due to aircraft design and paint color scheme, and must be checked on every installation.

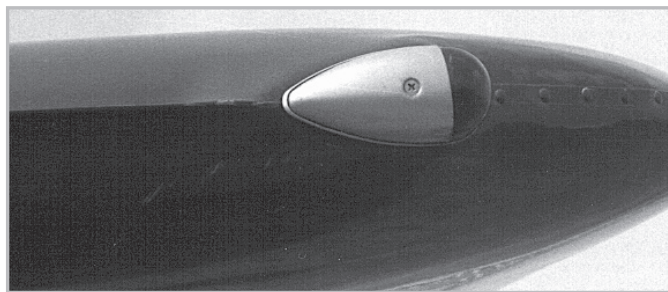

Before

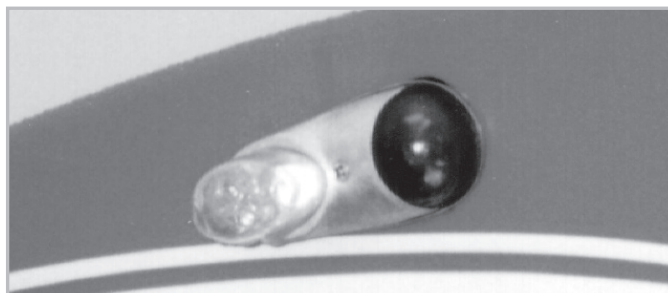

After/with Modified Wingtip

### Dimensions

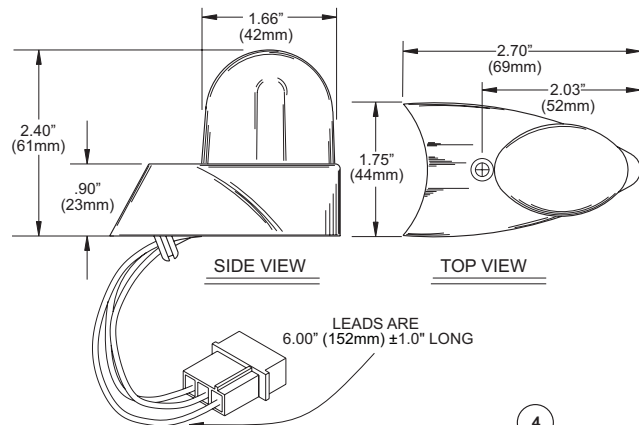

### A650 Spare Parts Exploded View

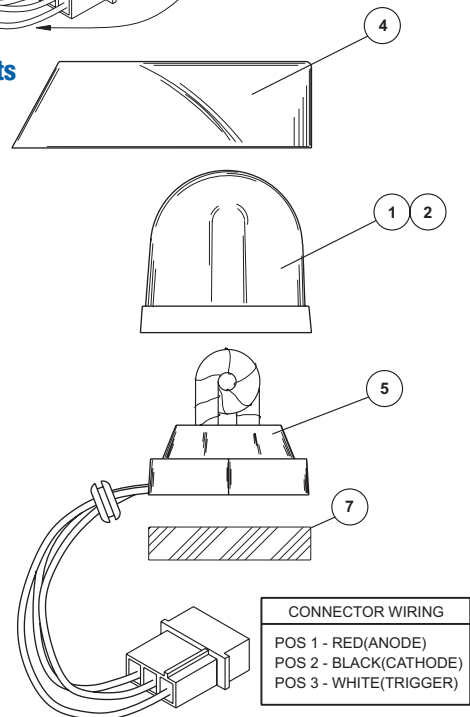

### Model A650 Series Parts List

QTY	QTY	ITEM	PART NUMBER	DESCRIPTION
	*		01-0770053-00	A650 STROBE ASSY.
	*		01-0770053-13	A650-D STROBE ASSY.(SHIELDED/CLEAR)
—	1	1	68-2290005-30	LENS, CLEAR (A612)
1	—	2	68-2290005-34	LENS RFI COATED (A612C)
—	1	4	19-170052-009	RETAINER, LENS (A626)
1	1	5	02-0250276-00	FLASHTUBE ASSEMBLY (A610)
1	1	7	38-0130106-00	A427-3 GASKET

# STROBE POWER SUPPLY CROSS REFERENCE REPLACEMENT LISTING

Old Part Number	Old Model Number	Description	Current Replacement
A413,HS-41-14	HS,41	Single strobe unit, SingleFlash, 14 VDC, 33 joule	<b>Model HDACF</b> P/N 01-0770028-05
A413,HS-41-28	HS,41	Single strobe unit, SingleFlash, 28 VDC, 33 joule	
A413,HD-14	HD	Dual strobe unit, SingleFlash, 14 VDC, alternating	
A413,HD-28	HD	Dual strobe unit, SingleFlash, 28 VDC, alternating	
A413,HD-42-14	HD,42	Dual strobe unit, SingleFlash, 14 VDC, alternating 33 joule	
A413,HD-42-28	HD,42	Dual strobe unit, SingleFlash, 28 VDC, alternating 33 joule	
A413,T2-14	HD,T2	Dual strobe unit, SingleFlash, 14 VDC, simultaneous, 16 joule	
A413,T2-28	HD,T2	Dual strobe unit, SingleFlash, 28 VDC, simultaneous, 16 joule	
A413,T2-DF-14	HD,T2,DF	Dual strobe unit, DoubleFlash, 14 VDC, simultaneous, 16 joule	
A413,T2-DF-28	HD,T2,DF	Dual strobe unit, DoubleFlash, 28 VDC, simultaneous, 16 joule	
A413,T3-14	HD,T3	3 strobe unit, SingleFlash, 14 VDC, w/trigger function	
A413,T3-28	HD,T3	3 strobe unit, SingleFlash, 28 VDC, w/trigger function	
A413,HD,DF-14	HD,DF	3 strobe unit, DoubleFlash, 14 VDC	
A413,HD,DF-28	HD,DF	3 strobe unit, DoubleFlash, 28 VDC	
A413,T3-DF-14	HD,T3,DF	3 strobe unit, DoubleFlash, 14 VDC, w/trigger function	
A413,T3-DF-28	HD,T3,DF	3 strobe unit, DoubleFlash, 28 VDC, w/trigger function	
A413A,HDA-DF-14	HDA,DF-14	4 strobe unit, DoubleFlash, 14 VDC	
A413A,HDA-DF-28	HDA,DF-28	4 strobe unit, DoubleFlash, 28 VDC	
A413A,HDA-DF-14/28	HDA,DF-14/28	4 strobe unit, DoubleFlash, 14 or 28 VDC	
A413A,HDA-CF-14/28	HDA,CF-14/28	4 strobe unit, CometFlash®, 14 or 28 VDC	
<hr/>			
A412A,HS-14	HS,14	Single strobe unit, SingleFlash, 14 VDC	<b>Model A490TSC</b> P/N 01-0770062-03
A412A,HS-28	HS,28	Single strobe unit, SingleFlash, 28 VDC	
A412A,HS,DF-14	HS,DF-14	Single strobe unit, DoubleFlash, 14 VDC	
A412A,HS,DF-28	HS,DF-28	Single strobe unit, DoubleFlash, 28 VDC	
A490,TS-14	HTS	Single strobe unit, SingleFlash, 14 VDC	
A490,TS-28	HTS	Single strobe unit, SingleFlash, 28 VDC	
A490A,TS,DF	HTS-DF	Single strobe unit, DoubleFlash, 14 or 28 VDC	
A490A,TS,CF-14/28	HTS-CF	Single strobe unit, CometFlash, 14 or 28 VDC	
<hr/>			
A490,T-14	HT	Single strobe unit, SingleFlash, 14 VDC	<b>Model HTCF</b> P/N 01-0770006-08
A490,T-28	HT	Single strobe unit, SingleFlash, 28 VDC	
A490,T,DF-14	HT,DF	Single strobe unit, DoubleFlash, 14 VDC	
A490,T,DF-28	HT,DF	Single strobe unit, DoubleFlash, 28 VDC	
A490,T,DF-14/28	HT,DF	Single strobe unit, DoubleFlash, 14 or 28 VDC	
A490,T,CF-14/28	HT,CF	Single strobe unit, CometFlash, 14 or 28 VDC	
<hr/>			
A490,TC,DF-14	HTC,DF	Single strobe unit, DoubleFlash, 14 VDC w/mtg. plate	<b>Model HTCCF</b> P/N 01-0770006-09
A490,TC,DF-28	HTC,DF	Single strobe unit, DoubleFlash, 28 VDC w/mtg. plate	
A490,TC,DF-14/28	HTC,DF	Single strobe unit, DoubleFlash, 14 or 28 VDC w/mtg. plate	
A490,TC,CF-14/28	HTC,CF	Single strobe unit, CometFlash, 14 or 28 VDC w/mtg. plate	
<hr/>			
	HR,14	Self-Contained Strobe, 14 VDC	<b>Model HRCFA</b> P/N 01-0770029-( ) Specify lens color R=Red, W=White S=Split Red/White
	HR,28	Self-Contained Strobe, 28 VDC	
	HR,DF,14	Self-Contained Strobe, DoubleFlash 14 VDC	
	HR,DF,28	Self-Contained Strobe, DoubleFlash 28 VDC	
	HR,DF,14/28	Self-Contained Strobe, DoubleFlash 14 or 28 VDC	
	HR,DFA,14/28	Self-Contained Strobe, DoubleFlash 14 or 28 VDC (A402A lens)	

## CONTINUED AIRWORTHINESS FLOW CHART

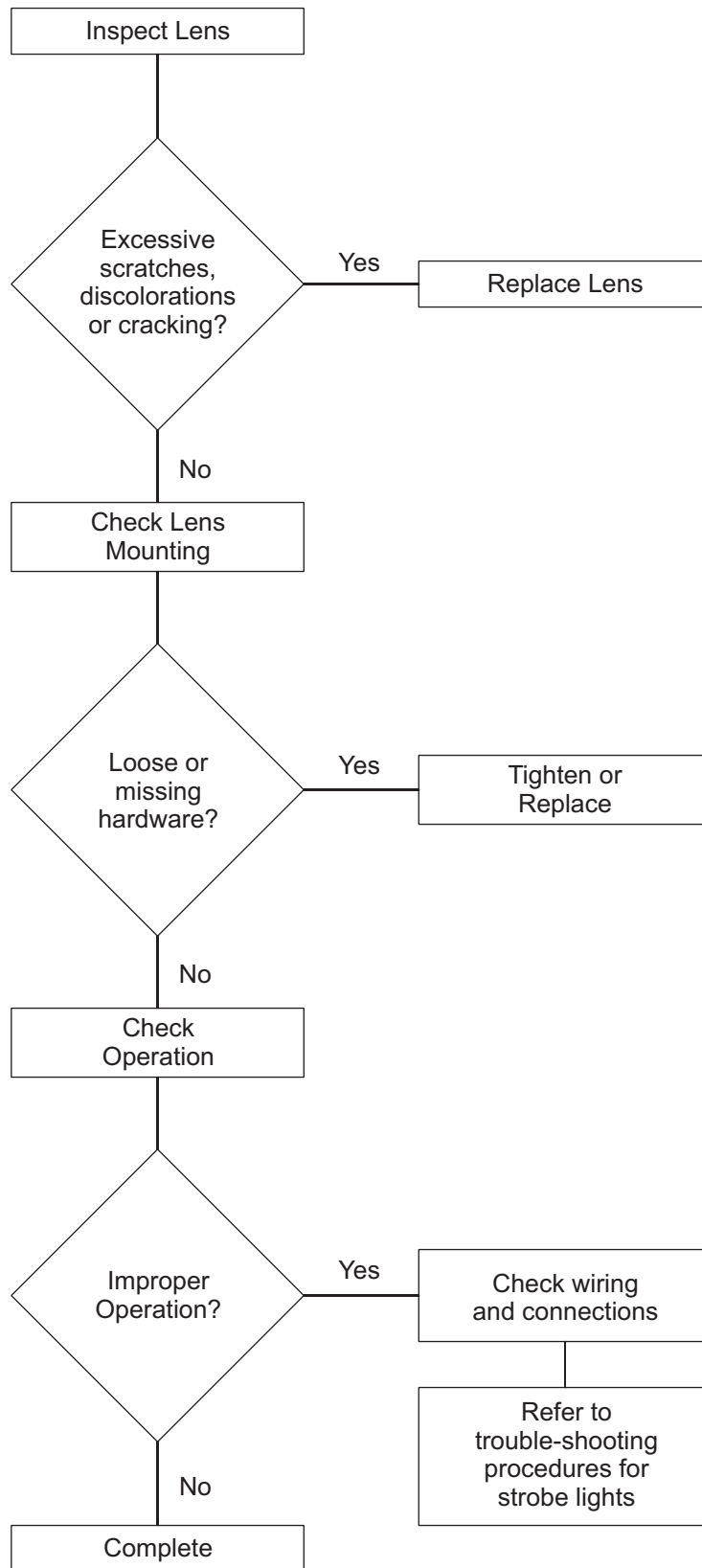

# STROBE SYSTEM TROUBLE-SHOOTING

## TROUBLE-SHOOTING PROCEDURES FOR AVIATION ANTI-COLLISION STROBE LIGHT SYSTEMS

WHEN REPAIRING WHELEN ANTI-COLLISION STROBE LIGHT SYSTEMS, USE ONLY WHELEN FAA APPROVED HARDWARE. BE CAREFUL OF STROBE LIGHT PARTS THAT ARE SIMILAR IN APPEARANCE!

The Whelen Aviation Strobe Light is a condenser discharge strobe light system. A condenser is charged to approximately 450 volts DC, then discharged across a xenon flash tube at controlled intervals. The condenser is parallel across the xenon flash tube that is designed to hold off the 450 volts DC applied, until the flash tube is triggered by an external pulse. This pulse is generated by a solid-state timing circuit in the power supply.

When trouble-shooting a strobe light system, first determine if the trouble is with the flash tube or the power supply. This can be accomplished by replacing the flash tube assembly with a good operating flash tube, or with the use of a Whelen Strobe Check unit.

Whelen's power supplies are protected against a short or open circuit on the output. In either case, the power supplies will effectively turn themselves off when subjected to a shorted output of a xenon flash tube that refuses to flash.

**WARNING:** Strobe light power supplies are meant to be used, not to remain in an inactive state. Use them at all times, this will improve their proper functioning. Any strobe light power supply that has been out of service for a long period of time is subject to failure because the electrolytic condenser loses the polarity formation. **A strobe light power supply not having been used for one year or longer is vulnerable to failure, applies to 1993 & older units.**

If this is the case, it is recommended to start operating the system on a voltage that is reduced by 25 percent for 10 to 15 minutes before putting the power supply into normal service. This will prevent overheating of the condenser while they reform. If the power supply, after a long period of non use, is operated at full voltage immediately, there is an excellent possibility that the condenser will become overheated.

### POWER SUPPLY TEST PROCEDURES

THE POWER SUPPLY IS A **HIGH VOLTAGE** DEVICE. LET THE POWER SUPPLY BLEED DOWN FOR 10 MINUTES AFTER TURNING OFF POWER BEFORE HANDLING.

**WARNING:** Reverse polarity of the input power, for just an instant, will permanently damage the power supply. This damage is sometimes not immediately apparent, but will cause failure later on.

External trigger switching is not provided on the A413A, HDA-DF Strobe Light Power Supply (Reference A413,T3-DF old style strobe light power supply, outlet #1). Do not short out high voltage for extended length of time; it will cause overheating of the output diodes and cause possible failure.

A normal operating power supply emits an audible tone. If there is no sound emitted, investigate.

1. Determine that there is a proper input voltage at the power supply. If this test is positive go to step 2.
2. Clear all possible shorts at the power supply, by disconnecting the output cables from the power supply outlets, and connect an operating strobe lighthouse assembly or a strobe check unit directly to the power supply outlet, then apply the required voltage to the power supply input. If this application proves positive the power supply is in working condition, and the problem may be with the interconnecting cables.

## CABLE CONTINUITY CHECK PROCEDURES

If pins 1 and 3 are reversed, or if there is a short between pins 1 and 2 of the interconnecting cable, the power supply will be rendered non-operable until the short is cleared. A short of this type will not cause any permanent damage to the power supply. However a discharge of the condenser across pin 1 and pin 3 will destroy the trigger circuit in the power supply.

1. Check for continuity between the connectors of each interconnecting cable:

Pin 1 to pin 1 (red wire = anode +).

Pin 2 to pin 2 (black wire = flash tube ground -).

Pin 3 to pin 3 (white wire = trigger).

2. Check for shorts between pins 1 and 2, pins 1 and 3, and pins 2 and 3 of the interconnecting cable.

**NOTE:** When pins 1 and 2, or pins 2 and 3 are reversed, the system will appear to operate normally, but these conditions will cause early flash tube failure, and void the flash tube warranty.

## XENON FLASH TUBE PROCEDURES

1. A xenon flash tube can be very photosensitive. One will flash normally when exposed to an external light source, but may become hard to fire when subjected to darkness.
2. They will become hard firing with age, or when exposed to a very high temperature. A hard firing tube will sometimes operate with the engine running, but will fail when operated on a low battery.
3. They can develop a leak through eggshelling of the glass, or a leak can develop around the seal of the wire to the glass. This is caused by hot and cold cycling of normal operating of the system.
4. They can go into self-ionization (continuously glow a light Blue), thus rendering the entire system non-operational until flash tube is replaced. This most likely occurs when the input voltage is highest. This can be checked by turning the system off. When turning the system back on, it generally will operate normally for a few flashes before going back into self-ionization.

ANY OF THE ABOVE MENTIONED CONDITIONS ARE REASONS FOR REPLACEMENT OF THE XENON FLASH TUBE.

**NOTE:** Installing one new flash tube in any multi-head strobe light system, will sometimes cause the remaining old flash tube to misfire or skip. This signifies that the old flash tube is nearing the end of its service life. However, to check the questionable flash tube, install it in a system and apply a reduced voltage, approximately 20 percent, to the input to the power supply. If the flash tube will operate at this reduced level, it still has a great deal of service life in it.

WHELEN'S CometFlash® ("CF") Strobe Light System consists of four high energy pulses per burst of light, 45 bursts of light per light.

**NOTE:** Whelen Engineering does not recommend attempting to repair their strobe light power supplies in the field. It is recommended to take advantage of our 48-hour Repair Service.



## R.F.I. and E.M.I. Problems (Radio Noise)

Whelen Engineering strobe light power supplies are designed with a low pass filter built in to keep R.F.I. and E.M.I. down to a minimum, however, sometimes there will be interference in the radios by the strobe light system. Most always, this is an installation problem, not a strobe light power supply problem.

The power supply should acquire its power from a low impedance source, such as the alternator or generator end of the electrical buss. Historically, the rotating beacon or strobe light circuit breaker is added on the electrical buss at the opposite end, with the radio in between the strobe breaker and the low impedance end of the electrical buss. Any noise generated by the power supply will be transmitted into the radio through the A+ input lead to the radio. Most of the new radio equipment manufactured today has inadequate input filtering, and any noise on the electrical buss is amplified in the radio and produced through the speaker and/or head phones loud and clear.

Two things can be done to alleviate the problem:

1. Connect the strobe light circuit breaker to the low impedance end of the electrical buss, using a 16 gauge jumper, as close to the battery as possible.
2. Install additional filtering in the radio A+ line, or provide an isolated A+ source for the radios by installing a filter choke in series with the radio input power lead and a filter adapter to ground and reference all radios to their filter. This will also improve the radio system from other line noises. REF 2200 mfd@50V Capacitor.

Frequently the noise is not on the A+ lead but is conducted through the ground circuit. Alternator, electrical motor, fuel pumps and strobe light power supplies draw heavy current through the ground circuit of the aircraft's frame. Any voltage drop in the ground circuit between the battery ground and the radio ground can look like a signal to the radios.

When the speaker, head phone and microphone use the aircraft's ground for return to the radios, one will always experience some interference. The amount of interference depends upon how much potential difference there is between the two ground points. Isolating the audio grounds from the airplane ground at the speaker, head phone and microphone junctions, and grounding the aforementioned with the radio at one central ground point, will eliminate the majority of all ground induced radio noise.

Do not parallel any audio leads with any power lead supplying energy to a noise generator; (i.e.) alternator, electric motor or DC choppers such as inverters and strobe light power supplies.

The interconnecting cable between the power supply and the remote strobe lighthouse assembly radiate very little, for the output circuit of the power supply is very low impedance. They can radiate RF like an antenna if the shield is not terminated to ground. The radiation of RF energy is reduced to a minimum by properly terminating the shield at one end or the other, generally the power supply end, but which ever proves the quietest ground. Do not terminate both ends.

When installing a strobe light system, provide a good ground and a low impedance source to the strobe light power supply. Eliminate ground loops in audio circuits by using a centrally located ground point for all audio grounds.

Whelen Engineering has available RF shielded flash tubes and strobe lighthouse assemblies to suppress the trigger pulse or clicking sometimes heard in the radios.

If noise problems persist, and the procedures described have not cleared them up, please contact the Whelen Engineering Company for assistance.

## STROBE SYSTEM TESTER

### Description

A strobe system tester designed to determine the reason the strobe light system is not working properly. This kit contains an instruction sheet and a trouble shooting procedure sheet. Test power supplies and interconnecting cables. It also comes with an adapter for testing Grimes and Hoskins strobe light systems.

Model Number	Part Number	Description
6542600	01-0765246-00	Strobe System Tester

Please Order Part Number: 01-0765246-00



Photos Show Typical Installations

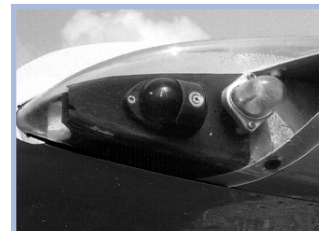

# PARTS BREAKDOWN - AIRCRAFT STROBE BEACONS

Model Number	Part Number	Description
5068500	01-0450685-00	Clamp Ring Assy.
A402AR	68-2170504-50	Optic Lens, Red
A402AS	68-2170504-60	Optic Lens, Split, Red/White
A402AW	68-2170504-30	Optic Lens, White
A424	11-430005-100	Taillight, Mounting Cup
A425	19-130000-100	Taillight, Lens Retainer
A425AH	19-0150350-01	Retainer, Horizontal Mount
A425AV	19-0150350-02	Retainer, Vertical Mount
A426	19-190000-009	Retainer for A428 Lens
A427	02-0250274-00	Strobe Tube Assy.
A427-4	38-0130107-00	Gasket/Spacer for A428 Lens
A428	68-4290001-30	Lens
A428C	02-0350033-00	Lens, Radio-shielded
A428D	02-0350057-00	Lens/Retainer Assy Radio-shielded
A435	02-0350054-00	Strobe Tube Assy, A430 Series
A440	19-130074-009	Mounting Adapter Ring
A441	01-0430011-00	Kit, 3 Pin Connector & contacts
A442	01-0410823-00	Kit, 3 Socket Connector & contacts
A443	02-0230081-00	Trigger Jumper Plug for HDACF
A444	02-0230007-00	Kit, 2 Pin Connector & contacts
A446	02-0230085-00	Kit, 2 Socket Connector & contacts
A455	38-0230002-00	Gasket, A457A Lens
A457A	68-4270002-30	Lens
A457AD	02-0350038-35	Lens, Shielded
A457BDH	02-0350038-37	Lens/Retainer Assy, Radio-shielded, Vertical Mounting
A457BDV	02-0350038-36	Lens/Retainer Assy, Radio-shielded, Horizontal Mounting
A469A	01-0770044-00	Strobe Tube Assy.(non reflective base)
A469B	01-0770044-02	Strobe Tube Assy.
A469D	01-0770044-01	Radio-shielded Strobe Tube Assy.
A469DK	01-0710834-00	Radio Shielding Kit for A469A
A504	06-150058-001	Disc, Lamp Socket for A555A Series
A506	02-0350034-00	Strobe Tube/Socket Assy. For A500A
A507	02-0350260-00	Lamp Socket for A555A Series
A50814	34-0412070-63	Halogen Lamp 14V 25 Watt
A50828	34-0428070-64	Halogen Lamp 28V 25 Watt
A605	02-0350259-00	Base Plate Assy. For A600 Series
A606	19-170049-009	Retainer for A600 Series
A610	02-0250276-00	Strobe Tube
A612	68-2290005-30	Magnifying Lens for A610
A612D	02-0350071-35	Lens/Retainer Assy. Radio-shielded used on A600 Series
A615	68-4250066-30	Taillight Lens used on A600 Series
A616	38-0130090-00	Gasket for A615 Taillight Lens
A626	19-170052-009	Retainer for A650 Series

Model Number	Part Number	Description
A626D	02-0350072-35	Lens/Retainer Assy. for A650 Series, Radio-shielded
H102	07-730068-000	Mounting Adapter for A470A Series
H103	11-230079-000	Mounting Adapter for A470A Series 3-3/4 dia mounting pattern
SA402	68-4230044-30	Lens, Clear for SACF & A450 Series
SA406	02-0350053-00	Strobe Tube for SACF & A450 Series
SA4181	38-0230104-00	Gasket for SA402 Lens
W1282	19-150002-009	Lens Retainer for W1285 Series
W1283	38-0230021-00	Gasket for W1284 Lens
W1284G	68-4230020-40	Position Light Lens, Green
W1284R	68-4230020-50	Position Light Lens, Red
W12852	02-0350003-01	Base Plate Assy.
W129014	34-0414020-65	Position Light Lamp, 14V
W129028	34-0428020-65	Position Light Lamp, 28V

A copy of the Whelen warranty regarding products described on these pages may be obtained free of charge from the Whelen Engineering Company, Inc., Chester, Connecticut 06412.

# PARTS BREAKDOWN - AIRCRAFT STROBE BEACONS

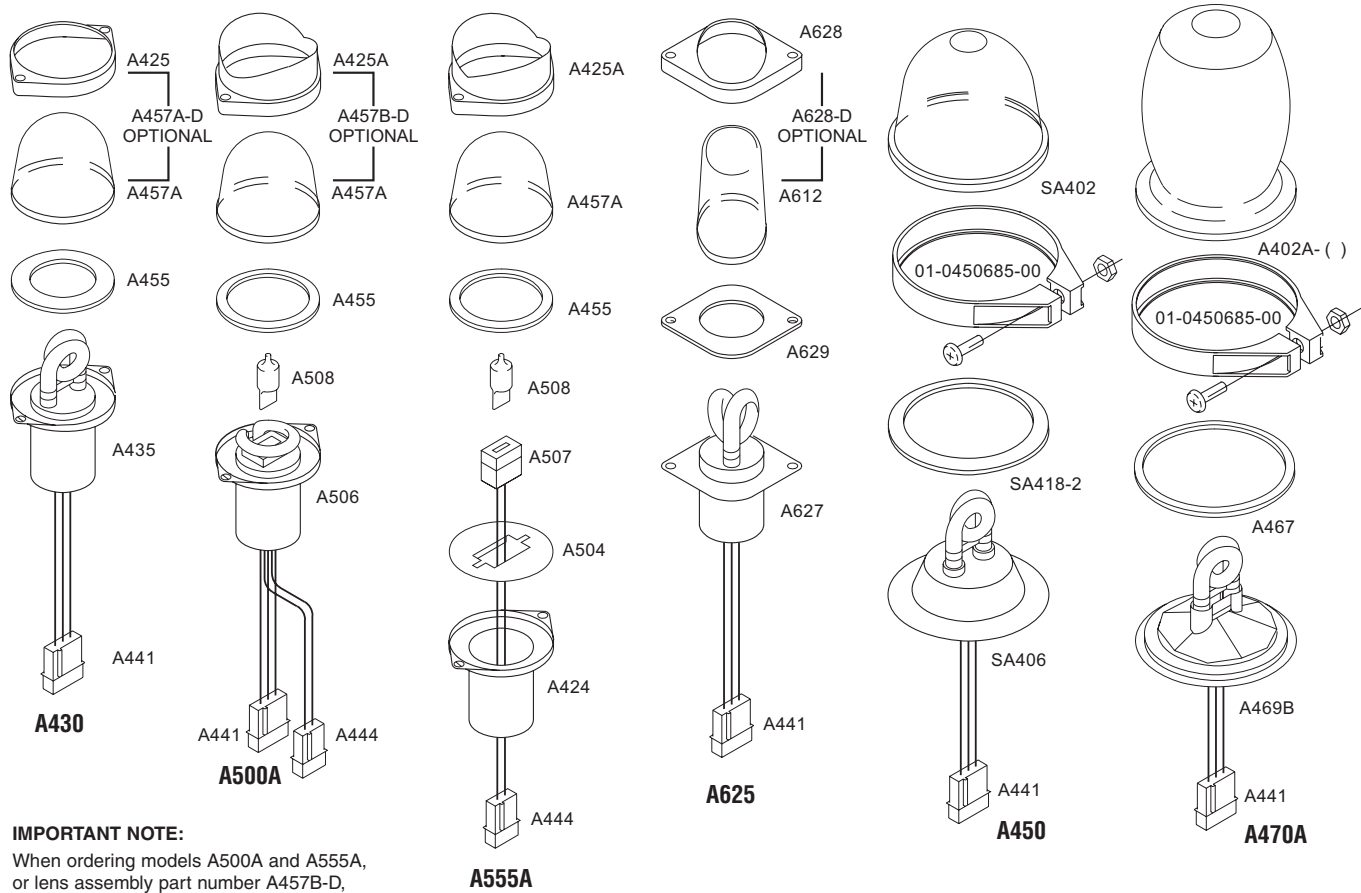

**IMPORTANT NOTE:**

When ordering models A500A and A555A, or lens assembly part number A457B-D, make sure to **SPECIFY HORIZONTAL OR VERTICAL**.

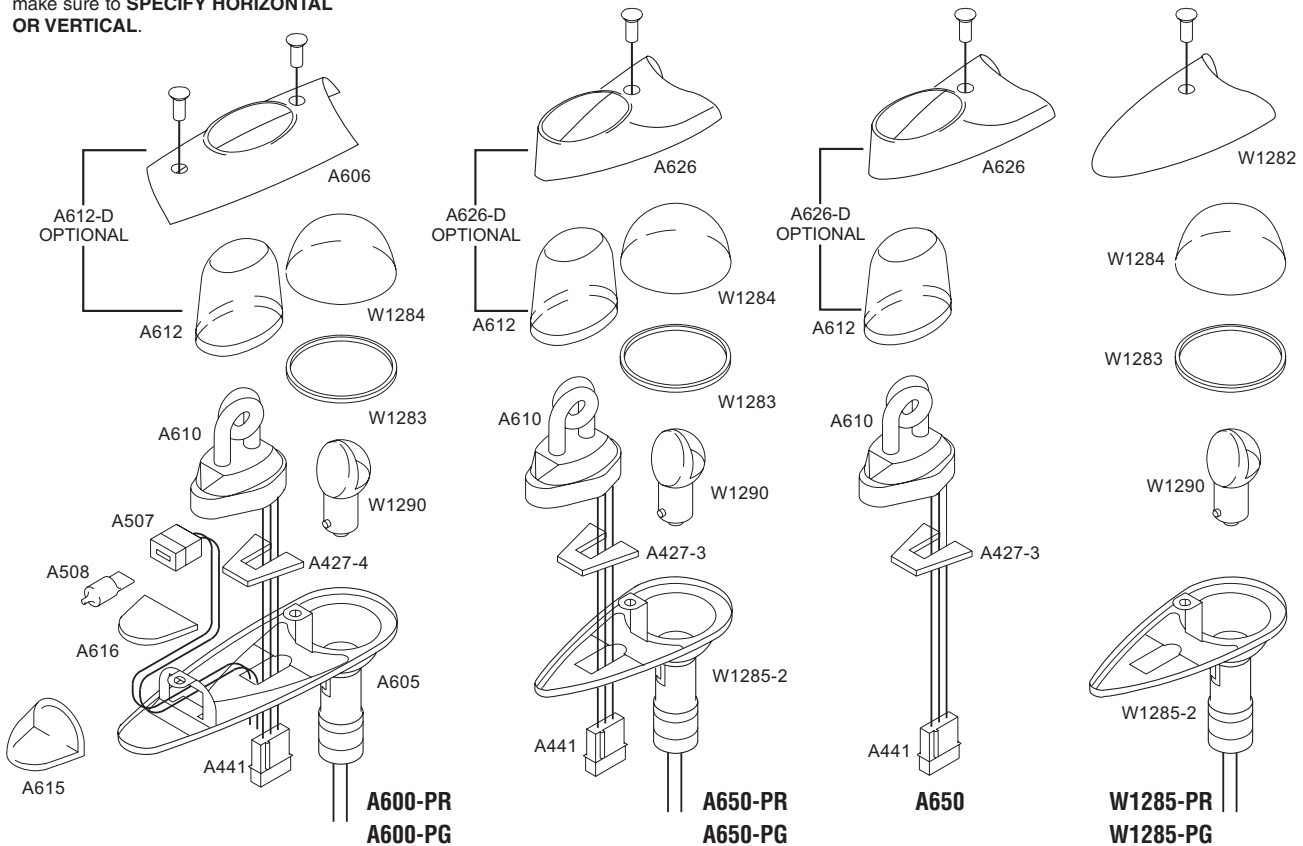

---

# NOTES

---

---

# NOTES

---





**LED & STROBE TECHNOLOGY  
FOR YOUR AIRCRAFT FROM  
WHELEN ENGINEERING...  
THE LEADER IN AVIATION LIGHTING!**



*Model 71055*



*Model 71141*



*Model 71110*



*For a complete look at  
Whelen Aerospace Technologies  
and it's line of Aviation Products...*

*Please visit us on the WEB at:*

***[www.flywat.com](http://www.flywat.com)***

Background Photo Courtesy of Cessna Flyer Magazine December 2008



**WHELEN** AEROSPACE TECHNOLOGIES

51 WINTHROP ROAD, CHESTER, CT 06412-0684

PHONE: (860) 526-9504

FAX: (860) 526-2009

[www.flywat.com](http://www.flywat.com)

### **WARRANTY & SERVICE REPAIR STATION**

#### **UNITED STATES:**

**Whelen Aerospace Technologies**

**51 Winthrop Road**

**Chester, CT 06412-0684**

**Tel: 860-526-9504**

**Fax: 860-526-2009**

**[www.flywat.com](http://www.flywat.com)**

**[info@flywat.com](mailto:info@flywat.com)**

### **SERVICE REPAIR STATIONS**

#### **CANADA:**

**Wright Instruments Ltd.**

**2762 Slough Street**

**Mississauga, Ontario**

**Canada L4T 1G3**

**Tel: 905-677-7161**

**Fax: 905-677-2188**

#### **OVERSEAS:**

**AAR Allen Group International**

**Kruisweg 705**

**P.O. Box 52**

**Hoofddorp, Netherlands 2130 AB**

**Tel: 31-20-6552213**

**Fax: 31-20-6533991**



*ISO 9001 Registered QMS*