



WHELEN AEROSPACE TECHNOLOGIES

Phone: (860) 526-9504  
Fax: (860) 526-2009  
Internet: www.flyWAT.com  
Sales/Service e-mail: info@flyWAT.com

**Installation Guide/ICA:**  
**Model 90615( )-series**  
**Model(s) 9061500, 9061510**  
**P/N:01-0790615-00, 01-0790615-10**  
**LED Dual Color Anti-Collision Light Assembly**

*TSO-C96a*  
*CLASS II (White)*  
*CLASS III (Red)*  
*APPROVED*

*The conditions and tests required for TSO approval of this article are minimum performance standards. Those installing this article either on or within a specific type or class of aircraft must determine that the aircraft installation conditions are within the TSO standards which include any accepted integrated non-TSO functions. TSO articles and any accepted integrated non-TSO function(s) must have separate approval for installation in an aircraft. The article may be installed only according to 14 CFR part 43 or the applicable airworthiness requirements.*

**SPECIFICATIONS:**

Nominal Operational Voltage: .....28 VDC  
(Operation from 22-32 VDC)  
LED Anti-Collision Light (Average):..... 0.9 Amps  
LED Anti-Collision Light (Pulse@0.25 sec.): 4.9 Amps  
Flashrate ..... 45± 5 per min.

Model 90615 is a combination White, Class II, and Red, Class III LED Anti-Collision Light.

**EQUIPMENT LIMITATIONS:** The baseplate must be mounted parallel to the vertical and horizontal centerlines of the aircraft to project the patterns properly.

An upper and lower unit is required to comply with the TSO-C96a requirements for a Class II Anti-Collision light system below the horizontal plane.

The white LED anti-collision light and red LED anti-collision light are not designed to be on at the same time.

Certain types of installations may require additional testing.

**AIRWORTHINESS LIMITATIONS:** The Airworthiness Limitations section is FAA approved and specifies inspections and other maintenance required under §43.16 and §91.403 of the Federal Aviation Regulations, unless an alternative program has been approved.

No airworthiness limitations are associated with the installation of the light assembly.

**CONTINUED AIRWORTHINESS:** The anti-collision light is designed with 8 vertical columns. Each column consists of 6 white and 6 red LEDs. Should any one LED fail the unit must be repaired or replaced. Inspect the lens. Replace if there is excessive scratching, pitting, discoloration or cracking. For additional lens maintenance detail, see SAE ARP5637.

**Note:** The unit has an internal diagnostic circuit to detect failures. The anti-collision light will automatically shut off after 9-10 flashes if a failure is detected.

**PERIODIC INSPECTIONS:** An annual inspection shall be performed unless the OEM specifies a shorter interval.

**INSTALLATION PROCEDURES:** The following information is to assist in the installation of a WAT Anti-collision light system.

1. The installation procedure described in the following text will be confined to a single light installation, but is identical for multiple light installations.

2. Connect the anti-collision inputs according to the chart shown. Connect the power leads to an appropriately sized breaker. Connections to be in accordance with FAA approved methods.
3. Using appropriate hardware, install the light assembly and insure that all leads are clear of any obstructions and secured as required. Secure light assembly using vibration resistant threaded fasteners.
4. Check all avionics systems for interference from this installation.
5. A flight check should be performed by a properly certified pilot.
6. When necessary, waterproof the light base to the aircraft. Apply single part silicone (RTV) or equivalent around any open area where water could get in.
7. If required, update aircraft records utilizing FAA Field Approval (Form 337) or equivalent.

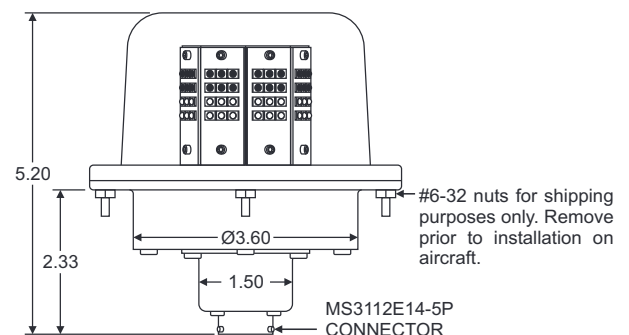
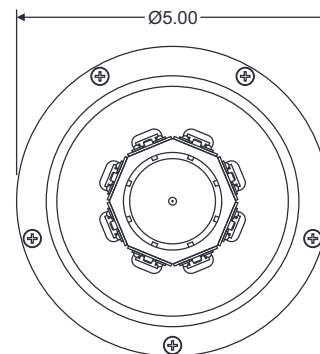

Aviation

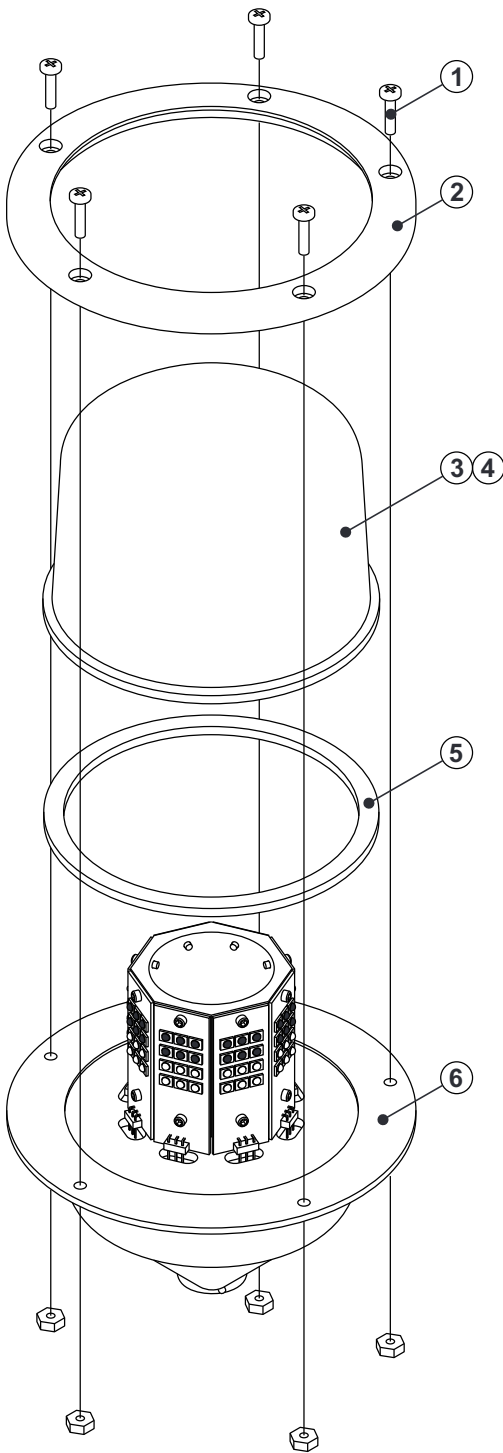

QTY	QTY	ITEM	PART NUMBER	DESCRIPTION
	*		01-0790615-00	MODEL 9061500 ANTI-COLLISION LIGHT ASS'Y (UPPER)
*			01-0790615-10	MODEL 9061510 ANTI-COLLISION LIGHT ASS'Y (LOWER)
5	5	1	14-0050503-34	SCREW, 6-32 X 1" PPHMS MS51957-34
1	1	2	19-171564-100	RETAINER, LENS
-	1	3	68-4150061A30	LENS, HARDCOAT
1	-	4	68-4151019A30	LENS, HARDCOAT w/DRAIN
1	1	5	38-0251018-00	GASKET, LENS
1	1	6		ASSY, ANTI COLLISION LIGHT 90615

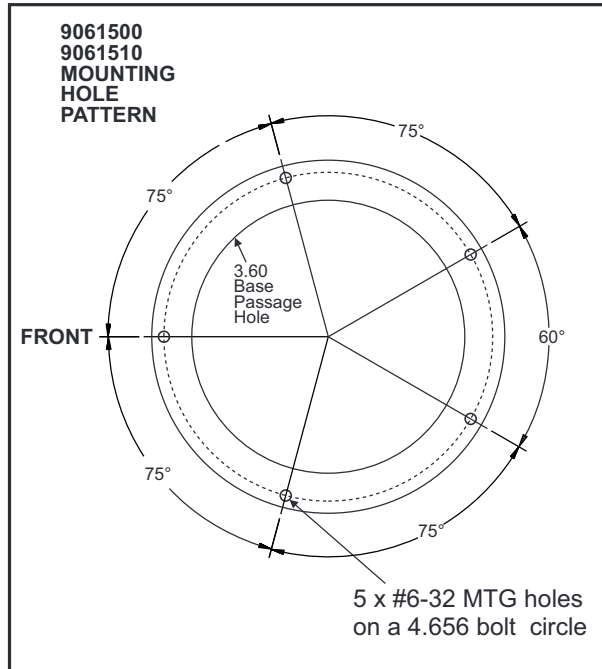

**CAUTION!** Do not touch the LEDs with either fingers or sharp objects, as this could soil or damage the LEDs and effect the optical performance of the light.

MS3112E14-5P CONNECTOR WIRING	
POS A	+28V A/C WHT
POS B	GROUND
POS C	+28V A/C RED
POS D	N/C
POS E	SYNCHRONIZE*

\*Low power Bi-directional control signal. Connecting to the synchronize signal of any Whelen LED anti-collision assembly will cause the lights to flash at the same time.

If synchronization is not necessary, the connection may be left open.