



WHELEN AEROSPACE TECHNOLOGIES

Phone: (860) 526-9504  
Fax: (860) 526-2009  
Internet: www.flyWAT.com  
Sales/Service e-mail: info@flyWAT.com

**Installation Guide/ICA:  
90340( )-series  
Models 9034001 - 9034010  
P/N: 01-0790340-01 through -10  
LED Position Light/Strobe Assembly**

TSO-C30c TSO-C96a  
TYPES I, II, III CLASS II  
APPROVED APPROVED

*The conditions and tests required for TSO approval of this article are minimum performance standards. Those installing this article either on or within a specific type or class of aircraft must determine that the aircraft installation conditions are within the TSO standards which include any accepted integrated non-TSO functions. TSO articles and any accepted integrated non-TSO function(s) must have separate approval for installation in an aircraft. The article may be installed only according to 14 CFR part 43 or the applicable airworthiness requirements.*

**POSITION LIGHT:**

**Operational Voltage:** . . . . . 14/28 VDC (nominal)  
**Input Current:** . . . . . 0.5 / 0.25 Amps

**EQUIPMENT LIMITATIONS:** An approved lighting system consists of two lights, one located on each wingtip. The baseplate must be mounted parallel to the vertical and horizontal centerlines of the aircraft to project the patterns properly. The strobe tube assembly must be connected to a strobe power supply, such as Whelen model 70888, 70879 or other approved models. Certain types of installations may require additional testing.

**AIRWORTHINESS LIMITATIONS:** The Airworthiness Limitations section is FAA approved and specifies inspections and other maintenance required under §43.16 and §91.403 of the Federal Aviation Regulations, unless an alternative program has been approved.

No airworthiness limitations are associated with the installation of this light assembly.

**CONTINUED AIRWORTHINESS:** The 90340 series LED wingtip position light assembly is designed with 3 forward LED's and two aft LED's. If any one LED fails, the unit must be repaired or replaced.

Note: To reduce eye strain use an optical filter such as dark glasses or a blue covering dome during LED inspection.

Inspect the lens. Replace if there is excessive scratching, discoloration or cracking. For additional lens maintenance detail, see SAE ARP5637.

**PERIODIC INSPECTIONS:** An annual inspection shall be performed unless the OEM specifies a shorter interval.

**INSTALLATION PROCEDURES:** The following information is to assist in the installation of a WAT 90340 Light System. Please refer to the OEM manual for your aircraft for specific removal and installation instructions.

1. Choose the appropriate 90340( ) series replacement light assembly.
2. Remove the old light, locate and save the existing +VDC lead and (-) ground lead. Clean and prep ends as required.
3. Make sure the existing system is equipped with an appropriate sized breaker. Connect the existing +14/28 VDC lead to the POSITIVE wire on the input cable assembly (supplied with the light assembly). Connect

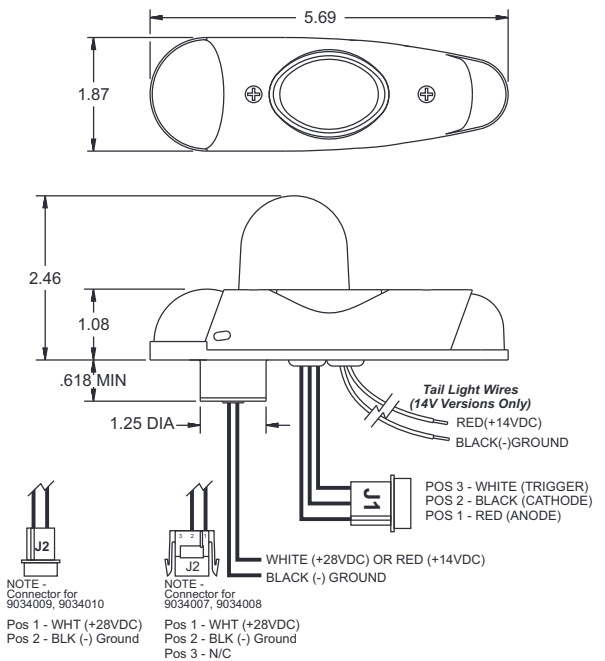

the existing ground lead to the GROUND wire on the input cable assembly or use the supplied connector as shown in the illustrations. Both leads must be connected by an approved FAA connection. Insure that the wire leads clear of any obstructions and ty-wrap as required. Connect the strobe, J1, to the strobe power supply as shown in the figure.

4. Remove the shroud from the light assembly. **CAUTION!** Do not touch the LEDs with either fingers or sharp objects, as this could soil or damage the LEDs and effect the optical performance of the light.
5. Position the base of the new light assembly onto the mounting surface. Insert three (3) #6-32 pan head screws into the mounting hole and tighten firmly. Reinstall the lens so that the two notches are positioned under the shroud, with each notch equidistant to the centerline.
6. Check all avionics systems for interference from the installation.
7. A flight check should be performed by a properly certified pilot.
8. If required, update aircraft records utilizing FAA Field Approval (Form 337) or equivalent.

Aviation

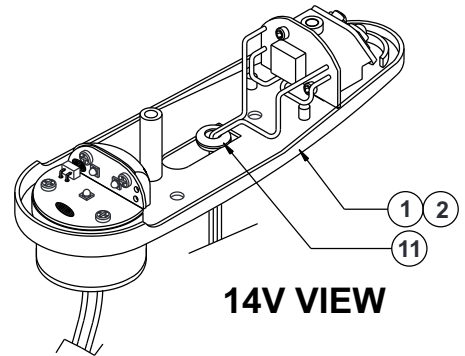
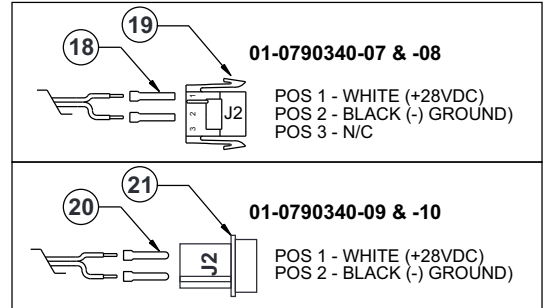
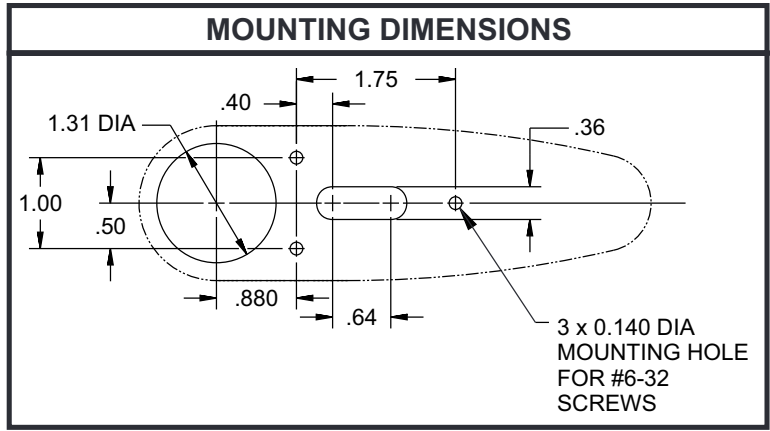
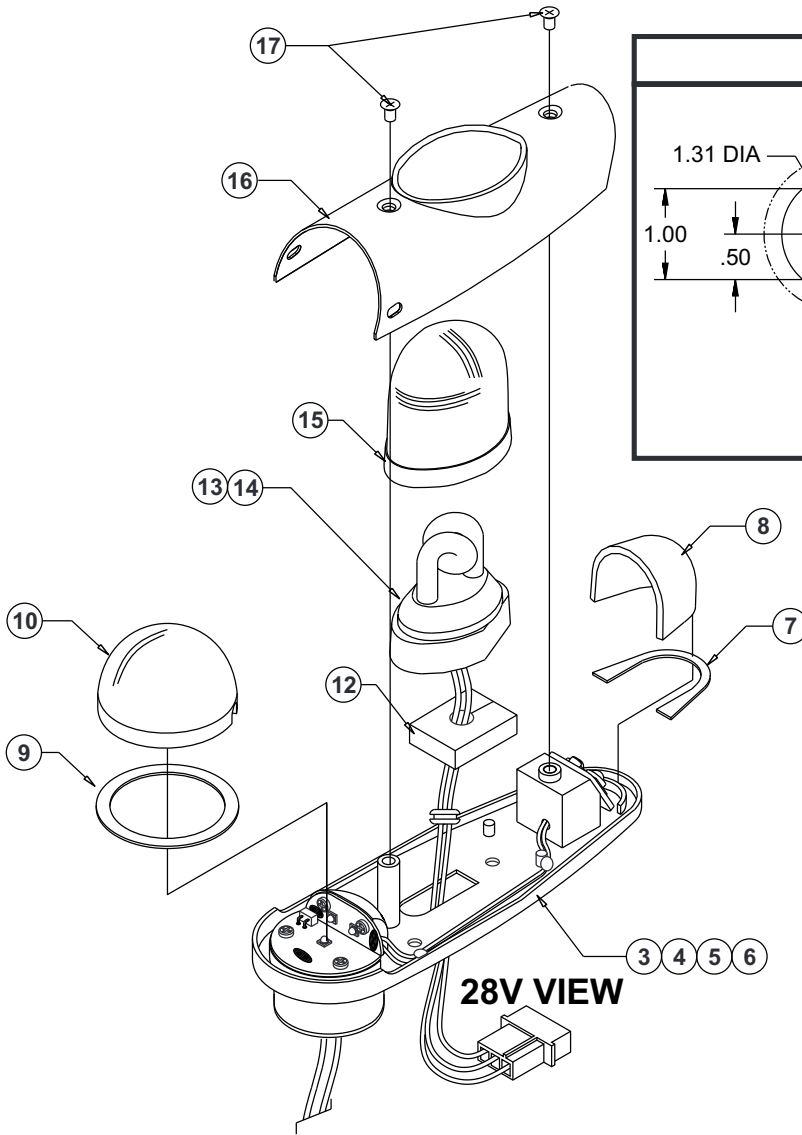

QTY.	QTY.	QTY.	QTY.	QTY.	QTY.	QTY.	QTY.	QTY.	QTY.	QTY.	ITEM	PART NUMBER	DESCRIPTION
										*		01-0790340-01	MODEL 9034001 FINAL ASSY (14V GRN, RFI)
										*		01-0790340-02	MODEL 9034002 FINAL ASSY (14V RED, RFI)
										*		01-0790340-03	MODEL 9034003 FINAL ASSY (28V GRN, RFI)
										*		01-0790340-04	MODEL 9034004 FINAL ASSY (28V RED, RFI)
										*		01-0790340-05	MODEL 9034005 FINAL ASSY (28V GRN, RFI)
										*		01-0790340-06	MODEL 9034006 FINAL ASSY (28V RED, RFI)
										*		01-0790340-07	MODEL 9034007 FINAL ASSY (28V GRN, RFI)
										*		01-0790340-08	MODEL 9034008 FINAL ASSY (28V RED, RFI)
										*		01-0790340-09	MODEL 9034009 FINAL ASSY (28V GRN, RFI)
										*		01-0790340-10	MODEL 9034010 FINAL ASSY (28V RED, RFI)
-	-	-	-	-	-	-	-	-	-	-	1		ASS'Y, ANTICOL/ POS LT GRN (14V)
-	-	-	-	-	-	-	-	-	-	-	2		ASS'Y, ANTICOL/ POS LT RED (14V)
-	-	-	-	-	-	-	-	-	-	-	3		ASS'Y, ANTICOL/ POS LT GRN (28V)
-	-	1	-	1	-	1	-	-	-	-	4		ASS'Y, ANTICOL/ POS LT RED (28V)
-	1	-	-	-	-	-	-	-	-	-	5		ASS'Y, ANTICOL/ POS LT GRN (28V)
1	-	-	-	-	-	-	-	-	-	-	6		ASS'Y, ANTICOL/ POS LT RED (28V)
1	1	1	1	1	1	1	1	1	1	1	7	38-0250901-00	GASKET, TAIL POSITION LIGHT MODEL 90340
1	1	1	1	1	1	1	1	1	1	1	8	68-3950903A30	LENS, CLEAR TAIL POSITION LT HARDCOAT
1	1	1	1	1	1	1	1	1	1	1	9	38-0230021-01	GASKET, POSITION LIGHT SPLIT
1	1	1	1	1	1	1	1	1	1	1	10	68-3950902A30	LENS, CLEAR FWD POSITION LIGHT
-	-	-	-	-	-	-	-	-	-	-	11	21-11061209-00	GROMMET, 3/16" ID
1	1	1	1	1	1	1	1	1	1	1	12	38-0130878-01	GASKET, FLASHTUBE, A600 (.375)
1	1	1	1	-	-	-	-	-	-	-	13	36-0050626-01	ASS'Y, FLASHTUBE 6.00" LEADS W/GROMMET
-	-	-	-	-	1	1	-	-	-	-	14	36-0050626-02	ASS'Y, FLASHTUBE 12.50" LEADS W/GROMMET
1	1	1	1	1	1	1	1	1	1	1	15	68-2290005-34	LENS, CLEAR/COATED A612
1	1	1	1	1	1	1	1	1	1	1	16	19-170049-010	RETAINER, A600 LENS COMPLETE
2	2	2	2	2	2	2	2	2	2	2	17	14-0050508-27	SCREW, 6-32 5/16 PFHMS CSNK MS51959-27
-	-	2	2	-	-	-	-	-	-	-	18	39-0501326-04	SOCKET, 20-14 AWG, .084 COMM MATE-N-LOK
-	-	1	1	-	-	-	-	-	-	-	19	39-0403811-04	HOUSING, 3 POS SCKT PANEL MT
2	2	-	-	-	-	-	-	-	-	-	20	39-0501316-04	PIN, 20-14 AWG
1	1	-	-	-	-	-	-	-	-	-	21	39-0402313-04	HOUSING, 2 POS PIN, COMM MATE-N-LOK